



# Advanced Power Meter

## PM17X PRO

### Installation and Operation Manual

---



BG0657 REV.A2

#### LIMITED WARRANTY

The manufacturer offers the customer a 24-month functional warranty on the instrument for faulty workmanship or parts from date of dispatch from the distributor. In all cases, this warranty is valid for 36 months from the date of production. This warranty is on a return to factory basis.

The manufacturer does not accept liability for any damage caused by instrument malfunction. The manufacturer accepts no responsibility for the suitability of the instrument to the application for which it was purchased.

Failure to install, set up or operate the instrument according to the instructions herein will void the warranty.

Only a duly authorized representative of the manufacturer may open your instrument. The unit should only be opened in a fully anti-static environment. Failure to do so may damage the electronic components and will void the warranty.

The greatest care has been taken to manufacture and calibrate your instrument. However, these instructions do not cover all possible contingencies that may arise during installation, operation or maintenance, and all details and variations of this equipment are not covered by these instructions.

For additional information regarding installation, operation or maintenance of this instrument, contact the manufacturer or your local representative or distributor.

For more details concerning technical assistance & support visit manufacturer's web site:

[www.satec-global.com](http://www.satec-global.com)

All trademarks are property of their respective owners.

April 2025

Copyright 2024-2026 © SATEC Ltd.

## WARNING

Read the instructions in this manual before performing installation and take note of the following precautions:

- Ensure that all incoming AC power and other power sources are turned OFF before performing any work on the instrument. Failure to do so may result in serious or even fatal injury and/or equipment damage.
- Before connecting the instrument to the power source, check the labels on the back of the instrument to ensure that your instrument is equipped with the appropriate power supply voltage, input voltages and currents.
- Under no circumstances should the instrument be connected to a power source if it is damaged.
- To prevent potential fire or shock hazard, do not expose the instrument to rain or moisture.
- The secondary of an external current transformer must never be allowed to be open circuit when the primary is energized. An open circuit can cause high voltages, possibly resulting in equipment damage, fire and even serious or fatal injury. Ensure that the current transformer wiring is secured using an external strain relief to reduce mechanical strain on the screw terminals, if necessary.
- Only qualified personnel familiar with the instrument and its associated electrical equipment must perform setup procedures.
- Do not open the instrument under any circumstances when it is connected to a power source.
- Do not use the instrument for primary protection functions where failure of the device can cause fire, injury or death. The instrument can only be used for secondary protection if needed.

Read this manual thoroughly before connecting the device to the current carrying circuits. During operation of the device, hazardous voltages are present on input terminals. Failure to observe precautions can result in serious or even fatal injury or damage to [equipment](#).

# Table of Contents

---

<b>Chapter 1</b>	<b>Introduction .....</b>	<b>9</b>
1.1	Features .....	9
1.1.1	Voltage Measurement Inputs .....	11
1.1.2	Current Measurement Input Options .....	11
1.1.3	Communications Interfaces.....	12
1.1.4	Built-in Digital inputs/outputs .....	12
1.1.5	Remote Displays.....	12
1.1.6	Optional Internal Add-on Module .....	13
1.1.7	Power inputs (power supply) .....	13
1.1.8	Upgradeable Firmware .....	13
1.2	Supplemental Documents .....	14
<b>Chapter 2</b>	<b>Device Description .....</b>	<b>15</b>
2.1	Modes of Operation .....	15
2.1.1	Operational Mode.....	15
2.1.2	Energy Test Mode .....	15
2.1.3	Service Mode .....	15
2.1.4	Diagnostics Mode.....	15
2.2	Communicating with the PM17X PRO.....	15
2.2.1	COM1-COM2 Serial Communications (standard).....	15
2.2.2	Infrared Port .....	16
2.2.3	USB Port.....	17
2.2.4	Ethernet Ports .....	17
2.2.5	Using PAS.....	17
<b>Chapter 3</b>	<b>Installation .....</b>	<b>18</b>
3.1	Mechanical Installation .....	18
3.1.1	Panel Mounting.....	18
3.1.2	DIN Rail Mounting.....	21
3.2	Remote Display Installation .....	22
3.2.1	Mechanical Installation .....	22
3.3	Electrical Installation .....	25
3.3.1	Typical Installation .....	25
3.3.2	Terminals.....	26
3.3.3	Power Source Connection .....	27
3.3.4	Connecting the wires.....	27
3.3.5	Power Source Connection .....	28
3.3.6	Voltage Input connection .....	28
3.3.7	Current Input Connection .....	29
3.3.8	Wiring Diagrams.....	29
3.3.9	DC voltage measurement .....	36
3.3.10	DC Current Measurement (Hall Effect Sensors).....	37
3.4	I/O Connections .....	38
3.4.1	Relay Outputs .....	38
3.4.2	Digital Inputs .....	39
<b>Chapter 4</b>	<b>Internal Optional Modules .....</b>	<b>40</b>
4.1.1	4RO Module .....	40
4.1.2	8DI Module .....	40

4.1.3	4DI/2RO Module.....	41
4.1.4	4AO Module .....	41
4.1.5	Current Inputs Module (future).....	42
4.1.6	PMU Module (future) .....	42
4.1.7	12/24V DC Input Power Module.....	42
4.2	Communications Connections.....	43
4.2.1	RS-485 Connection .....	44
4.2.2	Ethernet Connections .....	44
4.2.3	USB Connection.....	47
<b>Chapter 5</b>	<b>Operating with the PM17X PRO .....</b>	<b>48</b>
5.1	Communicating with the PM17X PRO.....	48
5.1.1	COM Serial Communication (Standard) .....	48
5.1.2	Ethernet Ports .....	48
5.1.3	USB Port (Standard) .....	48
5.1.4	Using PAS.....	48
5.2	Device Inputs .....	49
5.2.1	AC (or DC) Inputs.....	49
5.2.2	Voltage Inputs.....	49
5.2.3	Current Inputs.....	49
5.2.4	Sampling .....	49
5.2.5	Waveform Tracing .....	49
5.2.6	Digital Input.....	49
5.3	Device Outputs .....	50
5.3.1	Relay Output.....	50
5.3.2	Latched and Unlatched Operation .....	50
5.3.3	Pulse and KYZ Operation .....	50
5.3.4	Remote Commands .....	51
5.3.5	Retentive Relay .....	51
5.3.6	Critical Faults.....	51
<b>Chapter 6</b>	<b>Sensors .....</b>	<b>52</b>
6.1	High Accuracy Current Sensors .....	52
6.2	RS5 Current Sensor .....	53
6.3	Medium voltage sensor interface.....	53
6.3.1	LPVT/LPCT sensor interface.....	54
6.3.2	LPVT/5A sensor interface .....	55
6.3.3	LPVT/RS5 sensor interface .....	56
6.4	Grounding.....	57
<b>Chapter 7</b>	<b>Configuring the PM17X Analyzer .....</b>	<b>58</b>
7.1	Configuring current and voltage ratio .....	58
7.2	Configuring Correction Parameters .....	59
7.3	Sensors tested and approved by ABB .....	60
<b>Chapter 8</b>	<b>Display Operations .....</b>	<b>61</b>
8.1	Indicators and Controls.....	62
8.1.1	Display Diagnostics .....	62
8.1.2	Numeric LED Display .....	62
8.1.3	Load Bar Graph .....	62
8.1.4	Energy Pulse LED.....	62
8.1.5	Ethernet LEDs .....	62
8.1.6	Navigation Buttons.....	62
8.2	Data Display .....	63
8.2.1	Display Features .....	63
8.2.2	Navigation Buttons.....	64
8.2.3	Simple Reset of Accumulated Data .....	64
8.2.4	Common Measurements Display.....	65

8.2.5	Min/Max and Max. Demands Display .....	66
8.2.6	Harmonics Display .....	67
8.2.7	Energy Display .....	69
8.3	Status Display .....	71
8.4	Using the Menus .....	72
8.4.1	Navigation Buttons.....	72
8.4.2	Selecting Menus .....	72
8.4.3	Entering the Password.....	73
8.4.4	Selecting a Menu Entry.....	73
8.4.5	Viewing and Changing Setup Items.....	74
8.5	Menu Operations .....	75
8.5.1	Basic Device Settings .....	75
8.5.2	Device Options .....	76
8.5.3	Communication Ports .....	77
8.5.4	Network Address .....	78
8.5.5	Display Setup.....	79
8.5.6	Meter Security .....	80
8.5.7	Setting the Device Clock.....	80
8.5.8	Resetting Accumulators and Maximum Demands .....	82
<b>Chapter 9</b>	<b>Using PAS Software .....</b>	<b>83</b>
9.1	Installing PAS .....	83
9.2	Creating a New Site for your Meter .....	84
9.3	Setting up Communications.....	86
9.3.1	Communicating through a Serial Port.....	86
9.3.2	Communicating through the Internet .....	88
9.4	Setting Up the Meter.....	89
9.4.1	Preparing Setups for the Meter .....	89
9.4.2	Downloading Setups to the Meter .....	90
9.4.3	Uploading Setups from the Meter.....	90
9.5	Authorization.....	91
9.6	Upgrading Device Firmware .....	91
<b>Chapter 10</b>	<b>Configuring the PM17X PRO .....</b>	<b>93</b>
10.1	Configuring Communications .....	93
10.1.1	Setting Up Serial Communication Ports.....	93
10.1.2	Setting Up Ethernet.....	94
10.1.3	Setting Up RSTP in Daisy Chain mode .....	97
10.1.4	Setting-Up SNTP Client .....	98
10.1.5	Configuring eXpertPower Client.....	100
10.1.6	Setting Up TCP Notification Client.....	101
10.1.7	Meter Security .....	102
10.2	General Meter Setup .....	104
10.2.1	Basic Meter Setup .....	104
10.2.2	Device Options .....	107
10.2.3	Transformer Correction.....	109
10.2.4	Configuring Digital Inputs.....	110
10.2.5	Configuring Relay Outputs.....	111
10.2.6	Configuring Analog Outputs.....	115
10.2.7	Using Counters .....	117
10.2.8	Using Periodic Timers .....	119
10.2.9	Using Control Setpoints .....	120
10.3	Display Setup.....	125
10.3.1	Updating the meter Clock.....	125
10.3.2	Local Time Settings .....	125
<b>Chapter 11</b>	<b>Configuring Recorders.....</b>	<b>129</b>

11.1	Configuring Device Memory .....	129
11.2	Configuring the Event Recorder .....	132
11.3	Configuring the Data Recorder .....	133
11.3.1	Conventional Data Log Files .....	133
11.3.2	Factory Preset Periodic Data Logs .....	134
11.3.3	Factory Preset PQ Data Log .....	135
11.3.4	TOU Profile Data Log Files .....	136
11.4	Configuring the Waveform Recorder .....	137
11.5	Configuring IEEE1159 Power Quality Recorder .....	139
11.6	Fast Transient Recorder .....	142
<b>Chapter 12 Totalization Energy &amp; TOU Registers .....</b>		<b>143</b>
12.1	Configuring Summary and Bill./TOU Reg .....	143
12.2	Configuring TOU Daily Profiles .....	146
12.3	Configuring TOU Calendar .....	147
<b>Chapter 13 Configure Communication Protocols .....</b>		<b>149</b>
13.1	Configuring Modbus .....	149
13.1.1	Modbus Point Mapping .....	149
13.1.2	Changing 32-bit Register Format .....	149
13.1.3	Setting Modbus com port as master/client .....	150
13.2	Configuring DNP3 .....	151
13.2.1	DNP Options .....	151
13.2.2	Configuring DNP Class 0 Responses .....	154
13.3	Configuring IEC 60870-5 .....	155
13.3.1	Configuring IEC 60870-5 Options .....	155
13.3.2	Remapping Point Addresses and Event Reporting .....	159
13.3.3	Configuring Class 2 Data and Counter Transmission .....	160
13.4	Configuring IEC 61850 .....	161
13.4.1	Licensing IEC 61850 .....	161
13.4.2	Configuring IED Properties .....	162
13.4.3	Configuring Datasets .....	163
13.4.4	Configuring Report Control Blocks .....	164
13.4.5	Configuring the GOOSE Publisher .....	165
13.4.6	Configuring the GOOSE Subscriber .....	166
<b>Chapter 14 Device Control .....</b>		<b>169</b>
14.2	Remote Relay Control .....	169
14.3	Device Event Flags .....	170
14.4	Viewing and Clearing Device Diagnostics .....	171
14.5	Viewing Communication Status and Statistics .....	172
14.6	Resetting Accumulators and Clearing Log Files .....	173
14.6.1	Using PAS .....	173
<b>Chapter 15 Monitoring Meters .....</b>		<b>175</b>
15.1	Viewing Real-time Data .....	175
15.1.1	Organizing Data Sets .....	175
15.1.2	Polling Devices .....	176
15.1.3	Viewing a Data Table .....	177
15.1.4	Viewing Data Trend .....	177
15.1.5	Saving Data to a File .....	178
15.1.6	Printing Data .....	178
15.1.7	Copying Data .....	178
15.1.8	Real-time Data Logging .....	179
15.2	Viewing Real-time Min/Max Log .....	179
15.3	Viewing Real-time Waveforms .....	179
15.4	Viewing Real-time Min/Max Log .....	180
15.5	Viewing Real-time Waveforms .....	180

15.6	Viewing Real-time Harmonic Spectrum.....	182
<b>Chapter 16</b>	<b>Retrieving and Storing Files.....</b>	<b>185</b>
16.1.1	Uploading Files on Demand.....	185
16.1.2	Using the Upload Scheduler.....	186
<b>Chapter 17</b>	<b>Viewing Log Files.....</b>	<b>188</b>
17.1	General Operations.....	188
17.1.1	Opening a Log File.....	188
17.1.2	Copying Data.....	188
17.1.3	Saving Data to a File.....	188
17.1.4	Printing Reports.....	188
17.1.5	Customizing Views.....	188
17.2	Viewing Options.....	188
17.2.1	Customizing Views.....	188
17.2.2	Working with Tables.....	189
17.2.3	Working with Graphic Windows.....	189
17.3	Viewing the Event Log.....	192
17.4	Viewing the Power Quality Log.....	193
17.4.1	Viewing the Power Quality Log.....	193
17.4.2	Viewing the ITI (CBEMA) Curve.....	195
17.5	Viewing the Data Log.....	196
17.5.1	Viewing Data Trend.....	196
17.6	Viewing Waveforms.....	198
17.6.1	Viewing an RMS Plot.....	199
17.6.2	Viewing a Frequency Plot.....	199
17.6.3	Viewing a Spectrum Chart.....	199
17.6.4	Viewing a Spectrum Table.....	200
17.6.5	Waveform Options.....	200
17.7	Viewing Synchronized Waveforms.....	204
17.8	Exporting Files.....	205
17.8.1	Exporting Files in COMTRADE and PQDIF Formats.....	205
17.8.2	Exporting Files in Excel Format.....	206
17.9	Archiving Files.....	207
<b>Chapter 18</b>	<b>Technical Specifications.....</b>	<b>208</b>
18.1	Environmental Conditions.....	208
18.2	Construction.....	208
18.3	Power Supply Installation.....	208
18.4	Input Ratings.....	208
18.5	Optional Digital Inputs/outputs.....	209
18.6	Communication Ports.....	211
18.7	Real-time Clock.....	211
18.8	Standards Compliance.....	212
18.9	Special Sensor Interface.....	213
<b>Chapter 19</b>	<b>Analog Output Parameters.....</b>	<b>219</b>
<b>Chapter 20</b>	<b>Setpoint Triggers and Actions.....</b>	<b>220</b>
<b>Chapter 21</b>	<b>Parameters for Data Monitoring and Logging.....</b>	<b>223</b>
<b>Chapter 22</b>	<b>Billing/TOU Profile Log File.....</b>	<b>231</b>
<b>Chapter 23</b>	<b>Data Scales.....</b>	<b>232</b>
<b>Chapter 24</b>	<b>Device Diagnostic Codes.....</b>	<b>233</b>

## Chapter 1 Introduction

The PM17X PRO is the next generation's multi-function three-phase AC power meter specially designed to meet the requirements of users ranging from electrical panel builders to substation operators.

Bright 3-row LED display provides easy local meter readings. The display module is freely detachable and can be located at distance of up to 1000 meters from the device.

Integrated communication ports allow local and remote automatic meter readings and setup through the supplemental communication or user data acquisition software. Various communication options are available for remote communications with the meter including RS-485, 2 Ethernet connections.

The PM17X PRO series consists of three models:

- PM172 PRO - Base Product
- PM174 PRO - with IEEE1159 Power Quality (American Market)
- PM175 PRO - with EN 50160 Power Quality (European Market)



### 1.1 Features

- Up to 10 external inputs, triggered by external sources; onboard zero-sequence currents and voltages, current and voltage unbalance; cross triggering between multiple devices via digital inputs for synchronous event capture and recording
- IEEE 1159 Power Quality recorder: onboard power quality analyzer; programmable thresholds and hysteresis; IEEE 1159 PQ event log; ready-for-use reports; impulsive transients, sags/swells, interruptions, harmonics, inter-harmonics, frequency variation, voltage unbalance, optional IEC 61000-4-15 flicker
- EN 50160 Power Quality recorder: onboard power quality analyzer; programmable limits and hysteresis; power quality parameters measuring complies with IEC 61000-4-30 Ed.3.1 Class A, EN 50160 power quality event log, EN 50160 compliance statistics; ready-for-use compliance statistics reports; power frequency, voltage variations, rapid voltage changes, IEC 61000-4-15 flicker, voltage dips, interruptions, voltage swells, transient overvoltages, voltage unbalance, IEC 61000-4-7 harmonic and interharmonic voltage, mains signaling voltage
- Detailed information concerning EN 50160 Power Quality recorder in PRO see in the document "EM235/PM335/PM175/EM720 PRO EN50160:2022 Power Quality Recorder Application Note"
- IEEE 519 Power Quality recorder: onboard power quality analyzer; programmable limits; voltage and current harmonics measuring complies with IEEE 519, IEEE 519 power quality event log, IEEE 519 compliance statistics; ready-for-use compliance statistics reports
- Detailed information concerning IEEE 519 Power Quality recorder in PRO see in the document "EM235/PM335/PM175 PRO/EM720 PRO IEEE 519 Power Quality Recorder Application Note"
- Event recorder for logging internal diagnostics events, control events and I/O operations

- Sixteen Fast Data recorders: 1/2-cycle to 2-hour RMS envelopes; programmable data logs on a periodic basis and on any internal and external trigger; triggering from PQ recorder or control setpoints; exporting data trends in PQDIF file format (PAS)
- Eight Fast Waveform recorders: 8-channel simultaneous recording; selectable AC sampling rate of 32, 64, 128 or 256 samples per cycle; 20 pre-fault cycles; synchronized waveforms from multiple devices in a single plot; exporting waveforms in COMTRADE and PQDIF file formats (via PAS software)
- Embedded Programmable Controller: 64 control setpoints, OR/AND logic, extensive triggers, programmable thresholds and delays, relay control, event-driven data recording, cross triggering between multiple devices via ethernet for synchronous event capture and recording – up to sixteen triggering channels
- High-Class 3-phase Power meter: true RMS, voltages, currents, powers, power factors, and neutral current
- Class 0.2S IEC per 62053-22 / Class 0.2 per ANSI C12.20; four-quadrant active and reactive energy polyphase static meter
- Demand Meter: power, currents, voltages, harmonic demands
- Precise Energy and Power Demand Meter: Time-of-Use (TOU), 16 Summary (totalization) and TOU energy and demand registers for substation energy management; accumulation of energy pulses from external watt-meters; block and sliding demands; up to 64 energy sources
- Harmonic Analyzer: up to the 63rd harmonic voltages and currents; directional harmonics of power, voltage, current, power factor
- Voltage and currents unbalance
- 32 digital counters for counting pulses from external sources and internal events
- 16 programmable timers from 1/2 cycle to 24 hours for periodic recording and triggering operations on a time basis
- Network time synchronization (SNTP), 1-ms satellite-synchronized clock (IRIG-B) or PTP
- TCP notification client for communicating with a remote MODBUS/TCP server on events or periodically on a time basis, with any IP enable communication port
- 16GB Memory for long-term waveform and data recording
- Real Time Clock: Internal clock with backup battery for five years Real-Time Clock retention time
- 4 voltage and 4 current transformer-isolated AC inputs for connection to power line via potential and current transformers (in HACS version current channels should be connected to outputs of external HACS current transformers or similar current sensors only)
- LED bar graph showing percent load with respect to user-definable nominal load current
- Detachable display module with a 3-wire RS-485 interface; up to 1000 meters operation
- 2 built-in digital inputs for monitoring external contacts, and receiving pulses from energy, water and gas meters
- Easy to read 3-row (2x4 characters + 1x6 characters) bright LED display, adjustable update time, auto-scroll option with adjustable page exposition time, auto-return to a default page
- 1 built-in relay output for alarms and controls, and for output energy pulses

- Optional internal module (assembled internally during production). 4 solid state relays, 4 electro mechanical relays, 4 analog outputs, 6 channels current input module, 4 digital inputs and 2 relay outputs, 8 digital inputs
- 50/60 Hz operation
- Precise internal clock with battery backup
- Two Ethernet communication ports. 1 RS485 serial communication port
- Modbus RTU, Modbus/TCP, DNP3 serial, DNP3/TCP, IEC 60870-5-104 protocols and IEC 61850 Ed2 protocol
- Easy field upgrading device firmware through any communication port

### 1.1.1 Voltage Measurement Inputs

The PM17X PRO series features 4 high impedance voltage inputs:

- Rating: 10-1000 V AC L-L @ 50/60 Hz / 10-820 V DC 1
- Rating V4 300VAC
- Possibility to connect up to 3000 VDC via special accessory
- LPVT sensors (such as ABB KEVA sensors) according to IEC 61869-11
- $3.25/\sqrt{3}$  V secondary

### 1.1.2 Current Measurement Input Options

- 4 input currents for 3P system monitoring via numerous options:
- 1A rating: for standard CT secondary
- 5A rating: for standard CT secondary
- 20mA inputs designated for:
  - SATEC HACS CTs (High Accuracy Current Sensors)
  - Hall Effect Sensors for DC current
  - Fluxgate AC/DC sensors
- Flex Clamp: 200A/2V, 30A-300A-3000A/3V Rogowski coil
- GWP (Medium Voltage Sensor Input) - future
- PTS type – Pole Top Sensor (PTS) (assigned to the sensors such as Lindsey (Medium Voltage Sensor Input) –future.
- RS5: power meter with external CT of 5A (CS05S) nominal current – future
- LPVT sensors (such as ABB KECA sensors) according to IEC 61869-10
- 150mV/80A ratio. The device is also compatible with combined sensors KEVCY and KEVCD. All products feature RJ45 standard interface, designed for interfacing ABB digital protection relays. device fulfill the requirements of the accuracy class 0.5 (the meter itself is 0.2S).
- The ABB sensors have been approved for 2 current categories. Up to 650A and up to 4000A. - future

---

<sup>1</sup> UL listed as CAT-IV 300 V AC L-N, CAT-III 600 V AC L-N

### 1.1.3 Communications Interfaces

#### Built-in communication ports

- One serial communication port; RS-485, up to 115,200 bps, supporting MODBUS RsTU/ASCII, DNP3.0 and IEC 60870-5-101 protocols
- 2 Built-in ethernet 10/100Base-T ports (dual port ethernet) supporting MODBUS/TCP, DNP3.0/TCP, IEC 60870-5-104 protocols and IEC 61850 Ed2 protocol, up to 10 non-intrusive simultaneous connections per ethernet port (2 reserved for Expert power communication)
- Daisy chain capability with RSTP support or 2 independent Ethernet port. The Meter supports as default 20 chained connected devices
- SNTP, IRIG-B (1mSec accuracy) or PTP timing synchronization
- USB 2.0 port (type C), supporting MODBUS RTU protocol

### 1.1.4 Built-in Digital inputs/outputs

- DI: 2 optically isolated inputs, 24VDC dry contact; programmable de-bounce time from 1 ms to 1 s; control setpoints, pulse counters and Energy/TOU subsystem, 1ms sampling rate
- RO: 1 Solid State Relay output; unlatched, latched and pulse operations, failsafe operation for alarm notifications; programmable pulse width; direct remote relay control through communications

### 1.1.5 Remote Displays

The PM17X PRO can be ordered with a LED Remote Display Module (RDM17X) or an LCD Remote Graphical Module (RGM180). Both have a fast RS-485 port and communicate with the PM17X PRO via the MODBUS RTU protocol. Remote displays can be located at distances of up to 0.5 km from the device. The RGM180 can be ordered with an Ethernet 10/100Base-T port to communicate with the PM17X PRO over a local network.

The RDM17X PRO has two four-digit and one six-digit windows with bright red LEDs well suited for dark areas. It allows the user to view real-time RMS and harmonics measurements, status indication parameters, and perform basic setup operations when installing and servicing the device.

The RGM180 is equipped with a TFT color graphics LCD display with Touch Panel and has extensive dialog capabilities, allowing the user to view different fault and power quality information in a graphical form, such as waveforms, harmonic spectrum, phasors and data trends, review latest fault and power quality reports for fast fault analysis, and much more.

### 1.1.6 Optional Internal Add-on Module

PM17X might be ordered with an extra internal module adding more I/O's or extra functionality to the meter.

#### Optional extra module

- 4 RO: 4 relay outputs per module, Electro-Mechanic (EMR), or Solid State (SSR) relay option; unlatched, latched and pulse operations, failsafe operation for alarm notifications; programmable pulse width; direct remote relay control through communications.
- 4DI/ 2RO: Optically isolated status inputs are provided for status monitoring, pulse counting, external power demand period, and time synchronization. options for: dry contacts; 24V, 48V, 125V, 250V wet inputs; programmable de-bounce time from 1 ms to 1 sec; control setpoints, pulse counters and Energy/TOU subsystem; 1ms sampling rate. The 4DI/2RO module has two electro-mechanic relays (EMR) or solid state relays (SSR) outputs provided for energy pulsing, alarms, or remote control.
- 8 DI: 8 optically isolated inputs per module; options for: dry contacts; 24V, 48V, 125V, 250V wet inputs; programmable de-bounce time from 1 ms to 1 sec; control setpoints, pulse counters and Energy/TOU subsystem, 1pps time synchronization; 1ms sampling rate.
- 4AO: 4 analog outputs four analog outputs per module with internal power supply; options for 0-1mA,  $\pm 1$ mA, 0-20mA, 4-20mA (manually or remotely programmed).
- CIM: 6 channels current input module (future)
- PMU phasor measurement unit
- Fast transient module

### 1.1.7 Power inputs (power supply)

PM17X PRO supports AC power input as default

- AC range 80-264 V
- DC range 120-290 V DC  
DC power input might be ordered as an option
- Rating: 24VDC: 9-36 VDC

### 1.1.8 Upgradeable Firmware

The PM17X PRO series uses mass storage memory for storing device firmware. This allows upgrading of your device without replacing hardware components. New features can be easily added to your device by simply replacing firmware through any communication port.

## 1.2 Supplemental Documents

- BG0658 PM17X PRO SERIES MODBUS Reference Guide
- BG0614 EM235/PM335/PM17X PRO SERIES DNP3 Reference Guide
- BG0615 EM235/PM335/PM17X PRO SERIES IEC60870-5 Reference Guide
- BG0619 EM235/PM335/PM17X PRO SERIES IEC61850 Reference Guide
- BG0337 PAS Getting Started Guide

## Chapter 2 Device Description

### 2.1 Modes of Operation

The PM17x PRO can run in the following modes:

#### 2.1.1 Operational Mode

Operational Mode is the common operation mode. All device features are available.

When the device is in Operational Mode the CPU LED flashes for 1 second with a 1-second pause.

#### 2.1.2 Energy Test Mode

Energy Test Mode tests the device energy measurement accuracy. All basic measurements are available; energy accumulators are not affected; setpoints operation, fault and power quality recorders are stopped. To put the device into the Energy Test Mode, see in Device Options Menu Chapter 3, or Device Mode Control in Chapter 10.

#### 2.1.3 Service Mode

Service Mode is used for local upgrading of PM17X PRO firmware. When the device enters Service Mode, the CPU LED briefly flashes 2 times with a 1-second pause.

In Service Mode, all device operations are stopped.

#### 2.1.4 Diagnostics Mode

The device enters Diagnostics Mode when the internal diagnostics detects a critical error that affects the normal device operation. All device operations are stopped until the critical error is cleared. All communications ports are still available. See [Device Diagnostic Codes](#) in Chapter 24 for the list of diagnostic events that cause a critical error. See Device Diagnostics for more information on the PM17X PRO built-in diagnostics.

When the device is in Diagnostics Mode, the CPU LED briefly flashes 3 times with a 1-second pause, and the RDM display shows a diagnostic message.

For more information on indication and clearing the device diagnostics, see Status Information Display in Chapter 3, [Viewing and Clearing Device Diagnostics](#) in Chapter 14.

### 2.2 Communicating with the PM17X PRO

Communication with the PM17X PRO can be established independently and simultaneously through any communications port using the support PAS program supplied with the device or user application software. All communication ports are slave ports and have factory-preset parameters, such as baud rate, data format, and communications protocol that can be easily changed whenever desired.

#### 2.2.1 COM1-COM2 Serial Communications (standard)

The PM17X PRO has two standard serial communication ports COM1 and COM2 for communicating with the master workstations, RTUs, PLCs or PAS™@ PCs, and with an optional remote display. All serial ports operates in the RS-485 two-wire mode. The COM1 is an RS-485 versatile port and can be directly connected to the RS-232 port of a PC or a controller.

The COM2 port has different connection terminals and is intended for communication with the Remote Display Module (RDM) or Remote Graphical Module (RGM180). If the remote display is not used, the COM2 port can be used as a common RS-485 port.

All ports are optically isolated and can operate at baud rates up to 115200 bps. Each port can be set up for any communication protocol supported by the PM17X PRO independently from other ports. All ports are factory preset to 19200 bps, 8-bits/No-parity data format, and programmed for the Modbus RTU protocol.

See Configuring Serial Ports in Chapter 3 for information on how to set up serial ports in your device. For wiring diagrams, refer to the PM17X PRO Installation Manual.

ⓘ **Note**

The COM2 port DB15 pins 1 and 8 deliver 12VDC for powering the remote display module. Connecting the RS-485 wires to these terminals can cause permanent damage to your RS-485 port.

## 2.2.2 Infrared Port

The PM17X PRO has an optical infrared (IR) port for local retrieving data via a hand-held unit or a portable PC. The IR port can be equipped with an IEC- or ANSI-compatible optical head.

The IR port is identified in the PM17X PRO. It is factory preset to 19200 bps, 8-bits/No-parity data format, and programmed for the MODBUS RTU protocol.

The IR port is only available on the RGM180 attached to the IED.

### 2.2.3 USB Port

A USB node port is intended for local communications with the support PAS software. It is directly connected to your PC's USB port using the supplied USB cable. The USB communications does not require any settings. Just connect your PC to the PM17X PRO USB port and install the supplied USB driver (see Installing the USB Driver in Chapter 6). The USB communications is ten times faster than the serial communications can provide at a maximum baud rate.

### 2.2.4 Ethernet Ports

A 10/100Base-T Ethernet ports provides a direct connection of the PM17X PRO to a local area network through the TCP/IP protocols. The device has three onboard TCP servers configured for the Modbus/TCP (at TCP port 502), DNP3.0/TCP (at TCP port 20000) and IEC 60870-5-104 (at TCP port 2404) communications. The TCP servers can support up to 5 simultaneous connections with MODBUS/TCP, DNP3.0/TCP and IEC 60870-5-104 client applications.

Connection through the Ethernet port does not require device identification. The PM17X PRO responds to any device address and returns the received address in the response message.

#### ⓘ Note

To provide simultaneous file services for all ports, the PM17X PRO keeps independent file pointers for each communications port. For a TCP port, the PM17X PRO holds separate file pointers for each active TCP socket. The TCP server automatically closes a connection if a socket is idle for more than 5 minutes. There is no guarantee that a new connection is established at the same socket, so do not make any assumptions regarding the current file status when starting a new connection from your application. Always initialize a file pointer to a record from where you expect to begin reading a file. For more information, see "File Transfer" in the PM17X PRO MODBUS Communications Guide. Using the RDM and RGM.

The Remote Display Module (RDM) or Remote Graphical Module (RGM) is connected to the device's COM2 port using the RS-485 two-wire connection. The COM2 port connector has additional isolated 12VDC output terminals to power the RDM directly from the PM17X PRO. For information on using the RDM, see Chapter 3 "Using the RDM".

The remote display modules communicate with the PM17X PRO using the MODBUS RTU protocol. Both the COM2 port and the RDM/RGM RS-485 port are preset at the factory to 19200 bps, 8-bits/No-parity, address 1, and run the MODBUS RTU protocol. The baud rate can be increased up to 115200 bps (depending on the communications quality) through the RDM or service Terminal program.

### 2.2.5 Using PAS

PAS is the support software supplied with the PM17X PRO that gives the user basic tool for programming the device, performing remote control operations, monitoring real-time measurements, retrieving and analyzing historical data files, reviewing fault and power quality reports, and more.

PAS can communicate with the devices through any PM17X PRO port using the MODBUS RTU, MODBUS ASCII and DNP3.0 protocols.

For information on installing and using PAS, see Chapter 9 "[Using PAS Software](#)".

# Chapter 3 Installation

## 3.1 Mechanical Installation

### 3.1.1 Panel Mounting

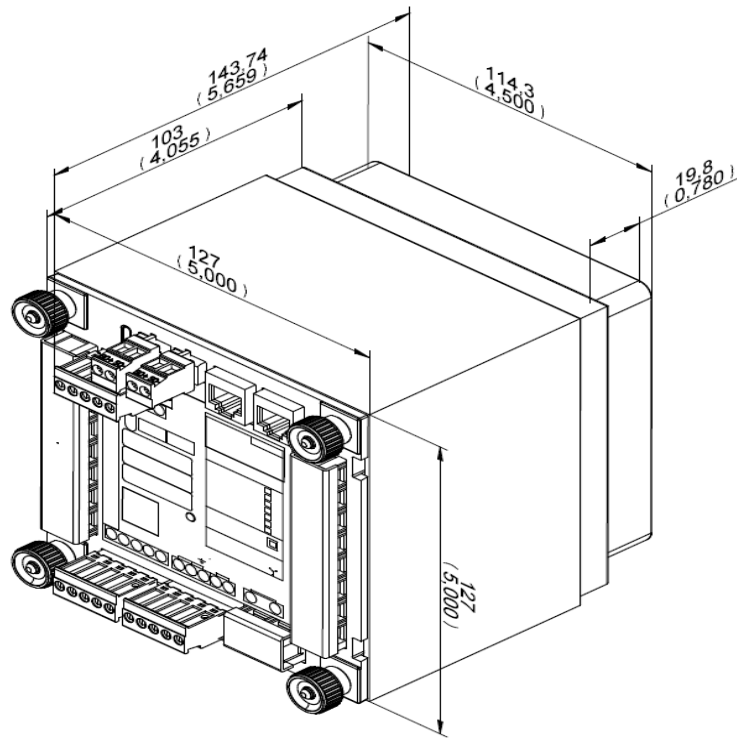
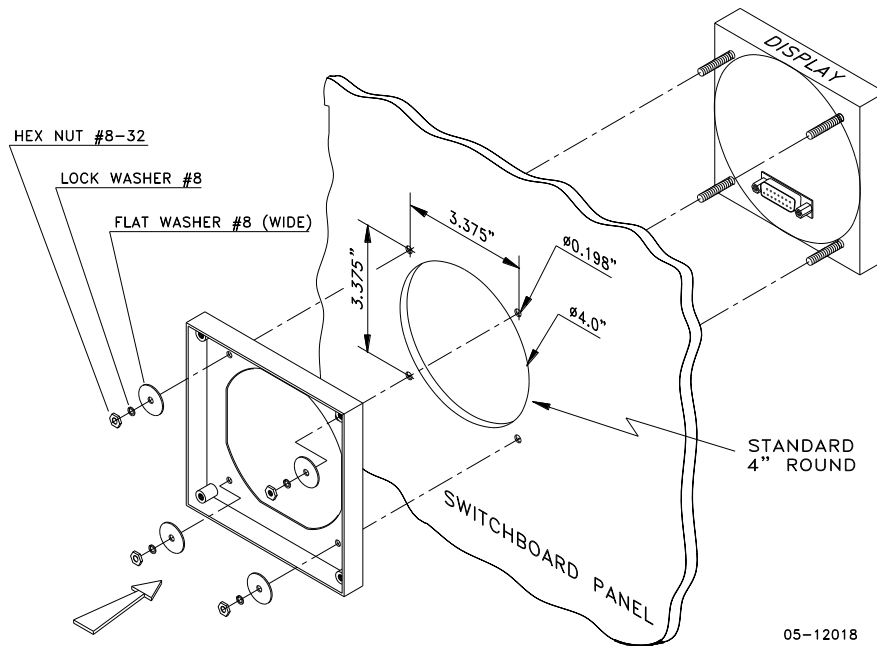

Figure 3-1 Dimensions



05-12018

Figure 3-2 STEP 1: (ANSI 4" round cutout): Mount the display module in cutout

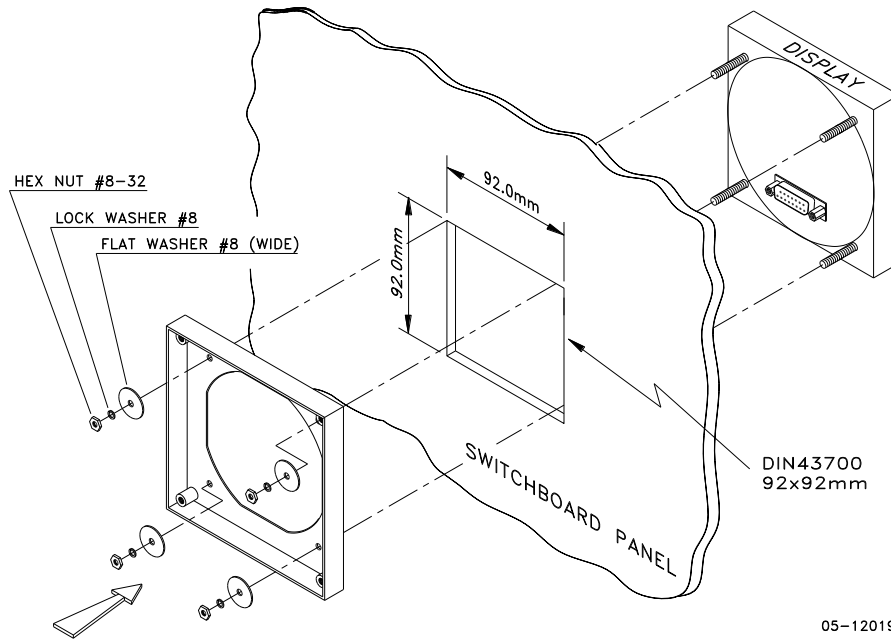

Figure 3-3 STEP 1: (DIN 92x92mm square cutout): Mount the display module in cutout

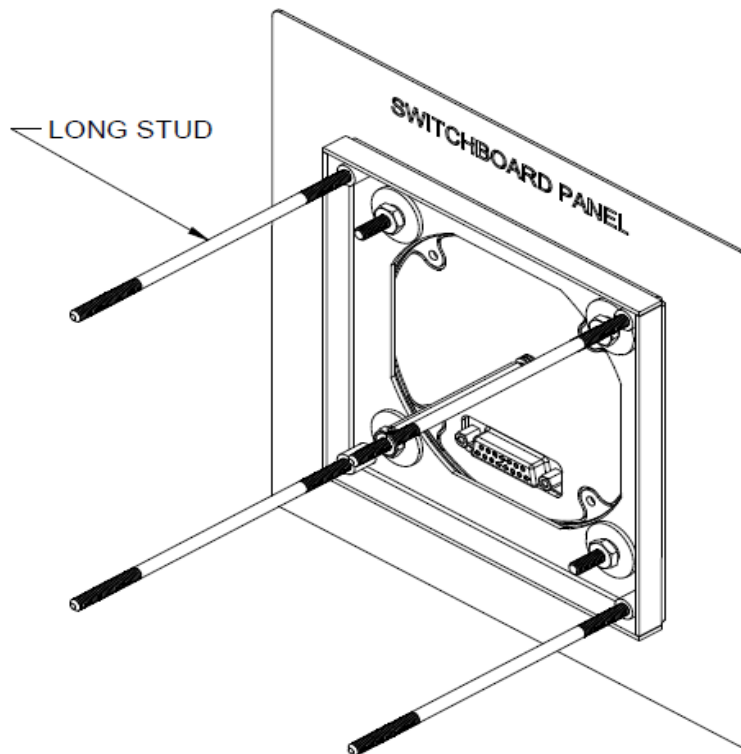

Figure 3-4 STEP 2: Assemble the four locating studs

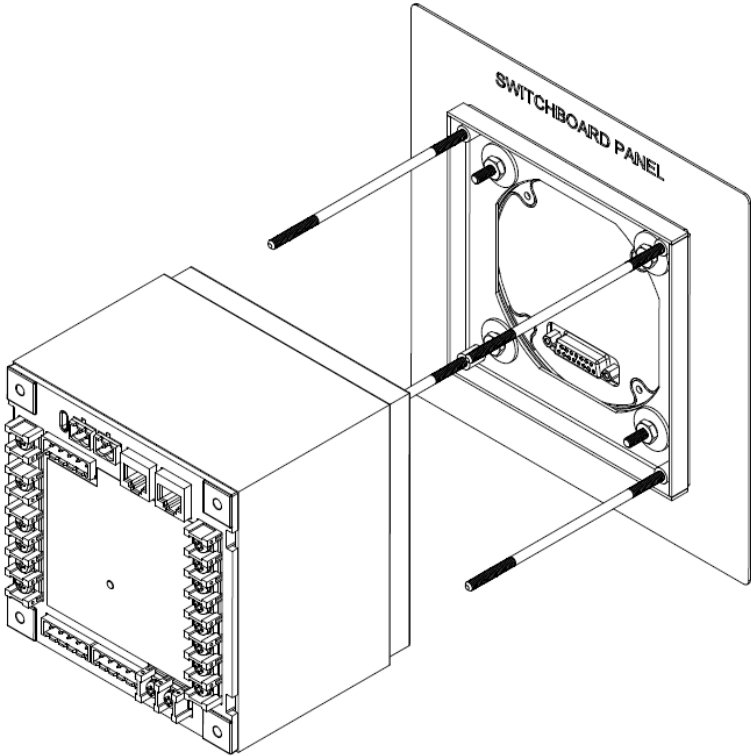

Figure 3-5 STEP 3: Slide and position the meter on locating studs

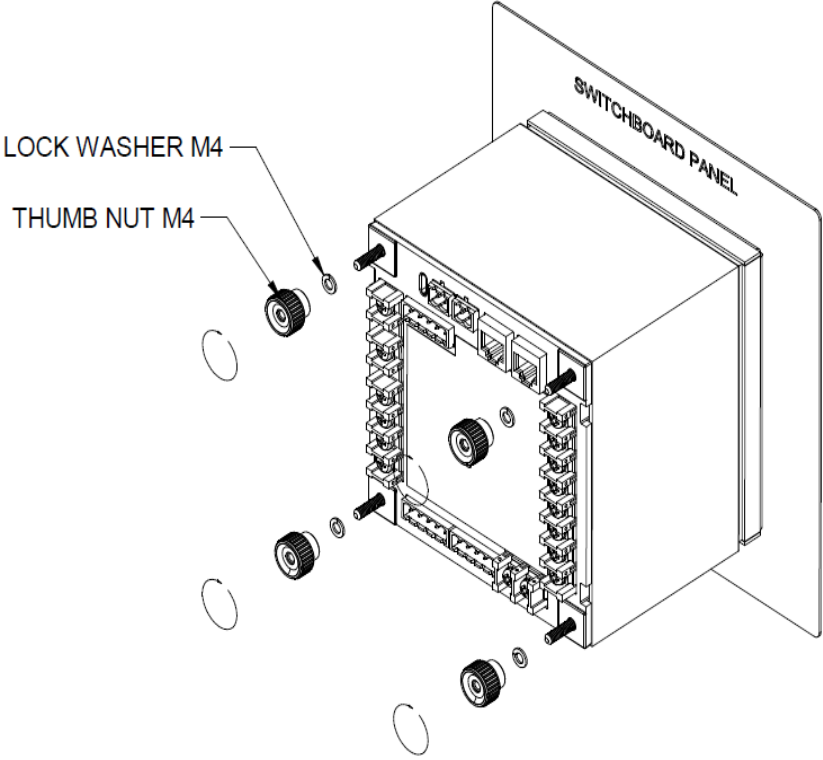
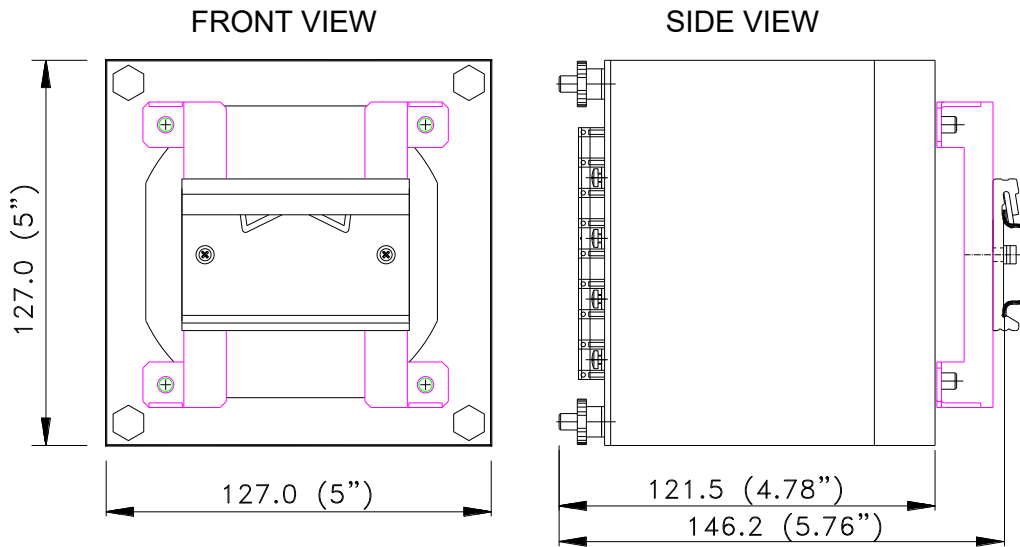

Figure 3-6 STEP 4: Affix the meter using the thumb nuts

### 3.1.2 DIN Rail Mounting

The PM17X PRO can be mounted on a 35-mm DIN rail. The display module is mounted separately on the switchboard panel and is connected to the meter by a communication cable (see “[Remote Display Installation](#)”).



BG0386-1

Figure 3-7 Dimensions

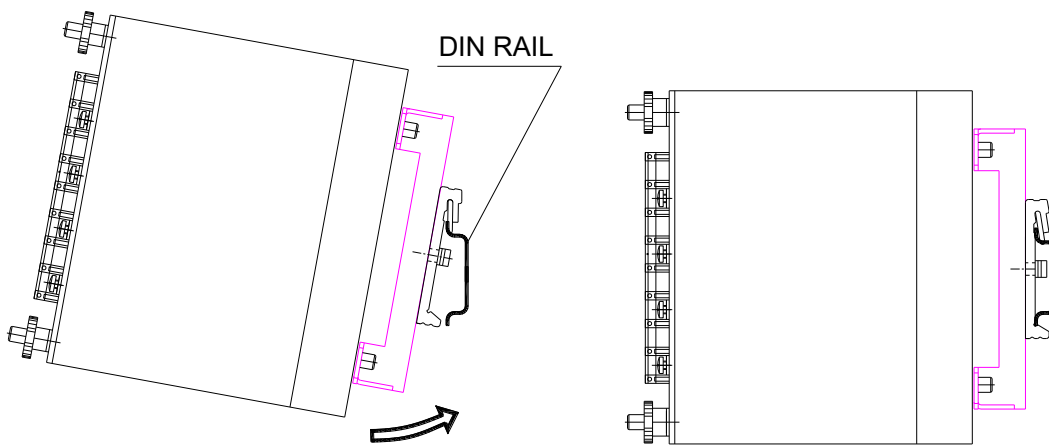

BG0386-2

Figure 3-8 DIN rail mounting

## 3.2 Remote Display Installation

### 3.2.1 Mechanical Installation

Standard Cutouts (ANSI 4" round or DIN 92x92 mm square)

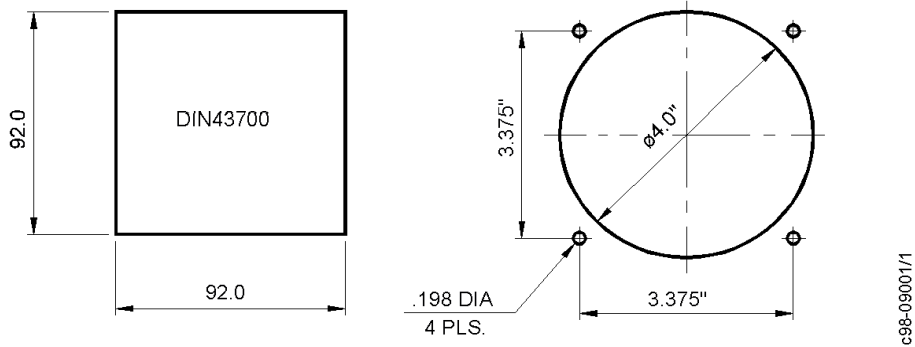

Figure 3-9 Display cutout dimensions

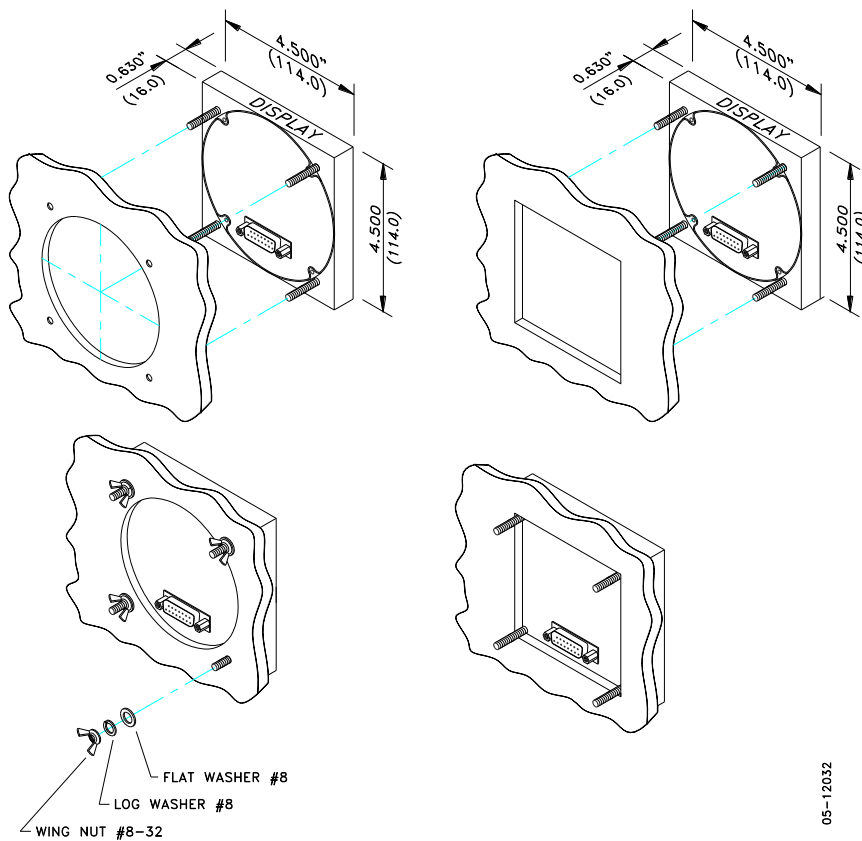

Figure 3-10 ANSI 4" or DIN 92x92 mm display mounting

STEP 1: Insert the display module into cutout.

STEP 2: Fasten washers and nut on screws.

Special Cutout

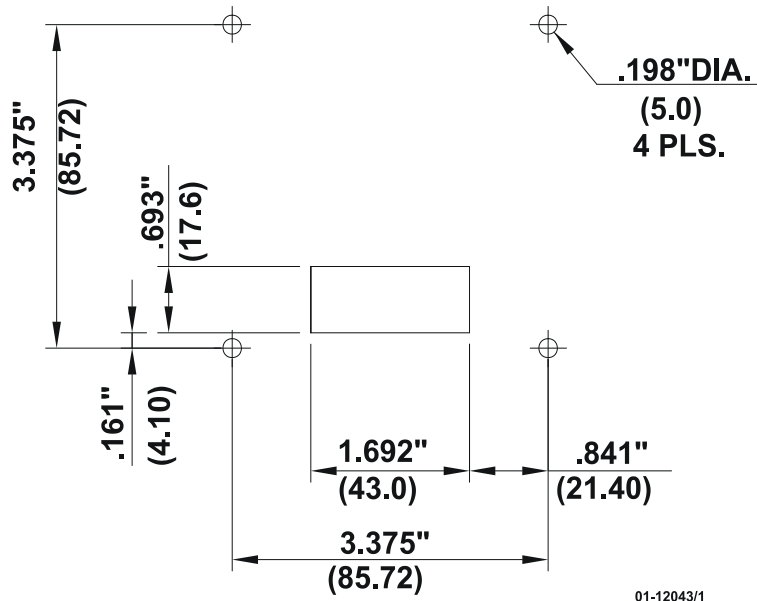

Figure 3-11 Panel cutout dimensions

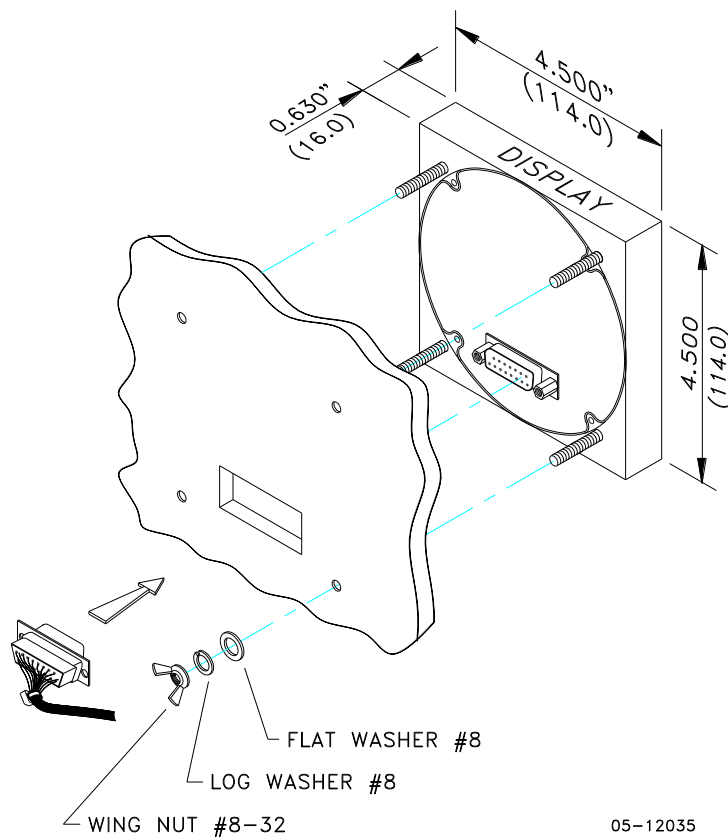

Figure 3-12 Display mounting

## Electrical Connection

The remote display is connected to the meter via a 3-wire or 5-wire communication cable provided with two 15-pin D-type connectors.

At distances of up to 3 m, the display can receive power through the communication cable directly from the meter. Connect pins 1 and 8 on both sides as shown in Figure 3-13.

At distances above 3 m, power should be provided from a separate 12V DC power source (a 12V AC/DC adapter can be used). Connect the positive wire to pin 1 and the negative wire to pin 8 as shown in Figure 3-14.

Pin	Signal
1	+12V
5	RS-485 + (plus)
7	RS-485 – (minus)
8	GND
15	Chassis ground

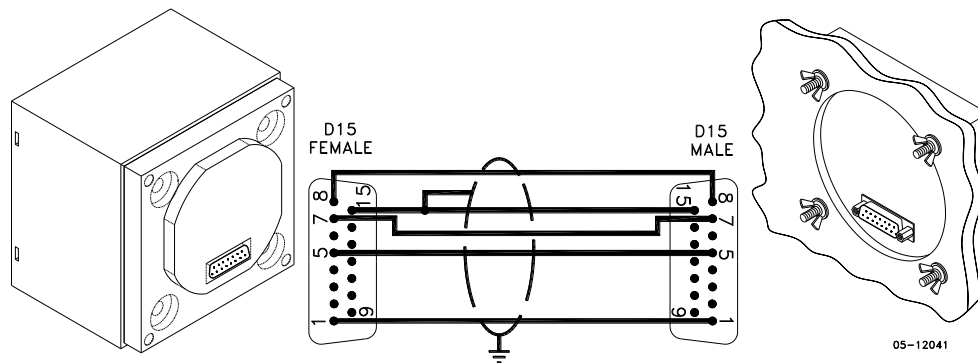

Figure 3-13 Self-powered remote display connection

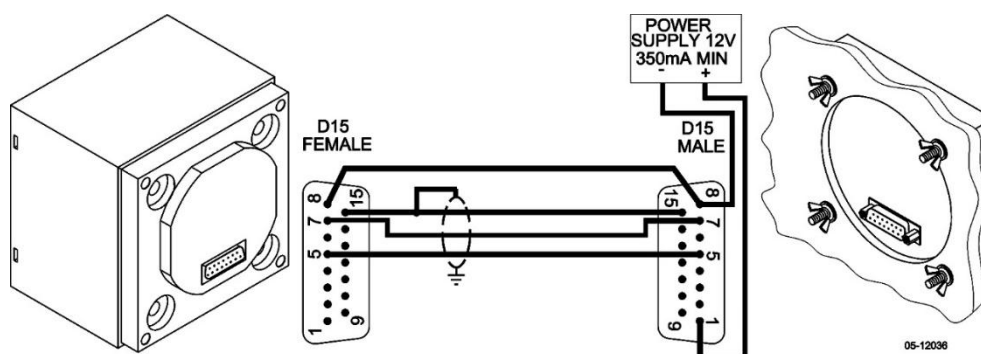

Figure 3-14 Remote display powered from a 12V DC power source

If required, the remote display may be connected to one of the regular meter back RS-485 port via a three-wire RS-485 communication cable using a separate 12V DC power source as shown in Figure 3-14. See [Communications Connections](#) for connector pin-outs and connection diagrams. The meter port settings must be as follows: Modbus RTU protocol, RS-485 interface, 19200 baud, 8-bits/no parity.

### 3.3 Electrical Installation

Before installation ensure that all incoming power sources are shut OFF. Failure to observe this practice can result in serious or even fatal injury and damage to equipment.

#### 3.3.1 Typical Installation

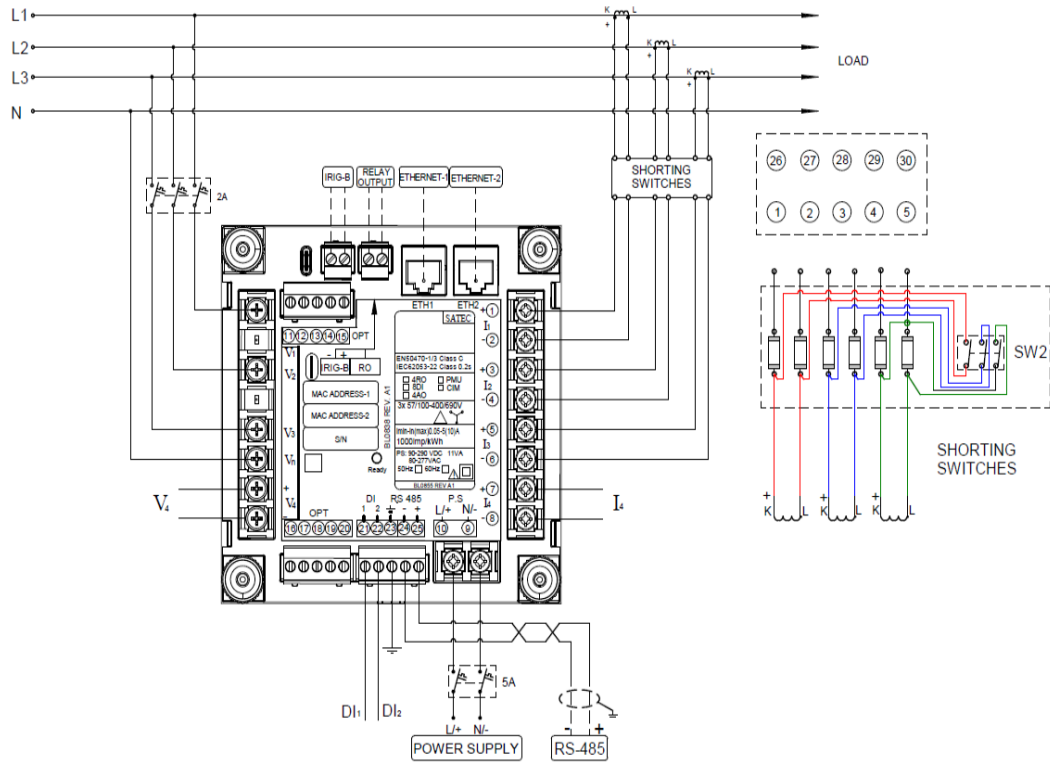
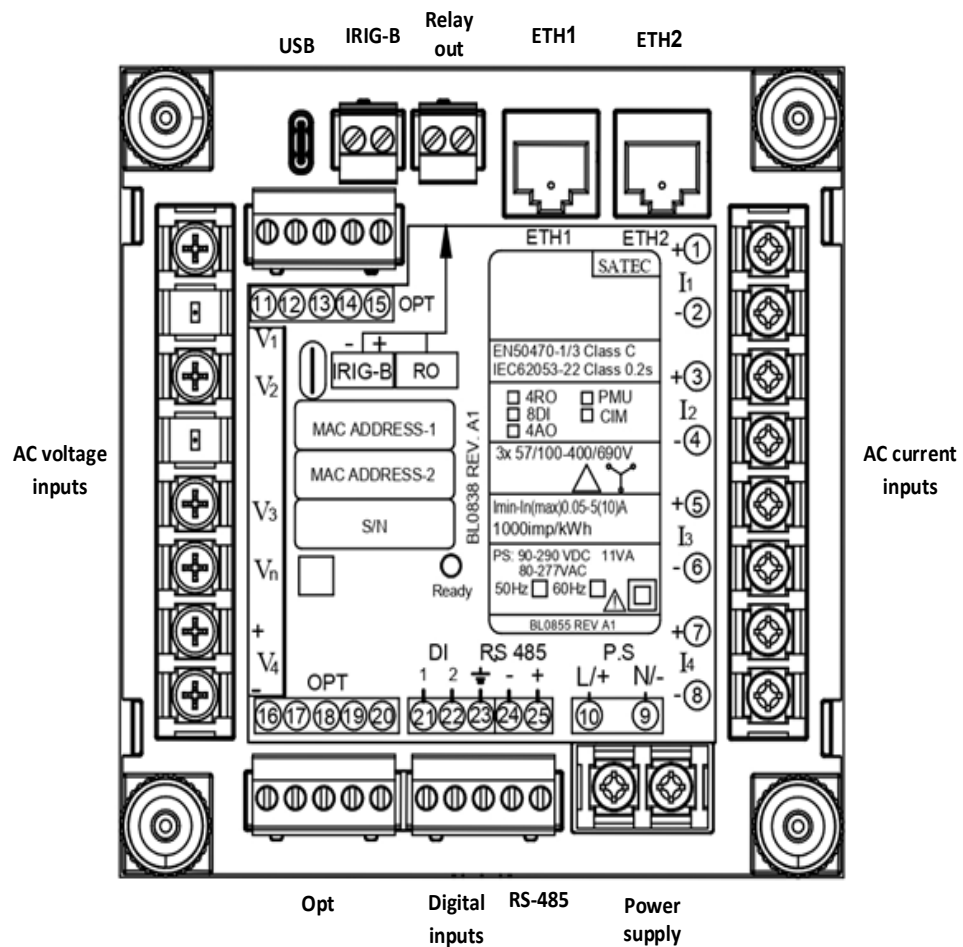

Figure 3-15 Typical Installation – 4LN3/4LL3 wiring mode

## 3.3.2 Terminals



PM17X contains the following connections on its back:

- USB-C port
- IRIG-B time sync input
- Relay output
- Ethernet1 port
- Ethernet2 port
- 4 AC current inputs
- AC/DC power supply input
- RS485 communication port
- 2 Digital inputs
- 4 AC voltage inputs

Note: Connections 11-20 are intended for internal optional module. The module functionality changes according to the internally installed module.

### 3.3.3 Power Source Connection

Before connecting your meter to the power source, check the label on the back of the device to ensure that it is equipped with the appropriate power supply.

The power source can be dedicated-fused, or from a monitored voltage if it is within the instrument power supply range.

AC power supply: connect the line wire to terminal 10 and the neutral wire to terminal 9.

DC power supply: connect the positive wire to terminal 10 and the negative wire to terminal 9.

### 3.3.4 Connecting the wires

All conductors must be stranded copper. All conductors and insulation systems and crimped devices must be appropriate for the application. SATEC recommends using crimped ferrules on stranded wire.

Table 1 below summarizes the different conductors' sizes to be used in the PM17X PRO series external connections.

**Table 1: Wiring Characteristics**

Terminals	Conductor size			Torque [Nm]	Notes
	PRO-model	Minimum AWG (mm <sup>2</sup> )	Maximum AWG (mm <sup>2</sup> )		
Aux. Power Supply Inputs L/+, N/-	ALL	22 (0.5)	12 (2.5)	0.5-0.7	Use 600V insulated conductors Required crimped ferrule: Panduit (22AWG) F75-8-M Panduit (12AWG) F81-10-M
Aux. Power Supply Inputs +, - (DC-DC Type)					
Voltages Inputs V1, V2, V3, Vn, V4+, V4-	ALL	22 (0.5)	10 (4)	0.5-0.6	Use 600V insulated conductors Required crimped ferrule: Panduit (22AWG) F75-8-M Panduit (10AWG) F82-15-M
Current Inputs I1, I2, I3, I4	ALL	12 (2.5)	10 (4)	0.35-0.4	Use 600V insulated conductors Required crimped ferrule: Panduit (12AWG) F81-10-M Panduit (10AWG) F82-15-M
COM, I/O connections		22 (0.5)	12 (2.5)	0.5-0.6	Use 600V insulated conductors Required crimped ferrule: Panduit (22AWG) F75-8-M Panduit (12AWG) F81-10-M

Minimum temperature rating of the cable to be connected to the field wiring terminals 75°C.

### 3.3.5 Power Source Connection

The equipment installation shall conform to the following instructions:

- a) a switch or circuit-breaker shall be included in the building installation;
- b) It shall be in close proximity to the equipment and within easy reach of the OPERATOR;
- c) It shall be marked as the disconnecting device for the equipment.



Before installing, ensure that all incoming power sources are shut OFF. Failure to observe this practice can result in serious or even fatal injury and damage to equipment.

The power source can be a dedicated fuse, or a monitored voltage if it is within the instrument power supply range.

#### To connect an AC power supply:

1. Connect the Line wire to terminal L/+
2. Connect the Neutral wire to terminal N/-

#### To connect to a DC power supply:

3. Connect the positive wire to terminal L/+
4. Connect the negative wire to terminal N/-

### 3.3.6 Voltage Input connection

The equipment installation shall conform to the following instructions:

- a) a switch or circuit-breaker shall be included in the building installation;
- b) It shall be in close proximity to the equipment and within easy reach of the OPERATOR;
- c) It shall be marked as the disconnecting device for the equipment.



Before installing, ensure that all incoming power sources are shut OFF. Failure to observe this practice can result in serious or even fatal injury and damage to equipment.

#### 690V Inputs

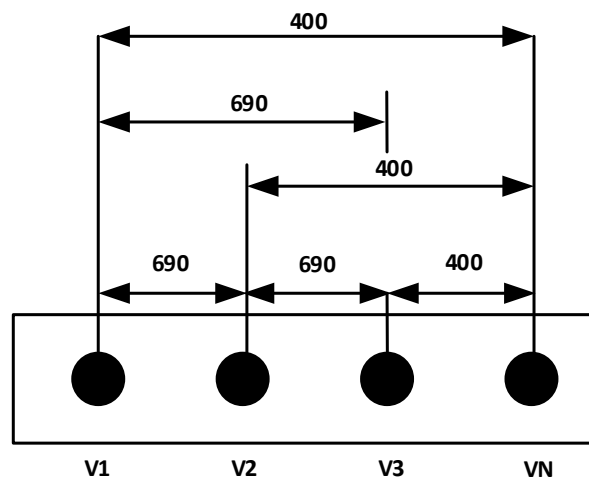

Figure 3-16

690V inputs are usually used with direct connection. Use any of the seven wiring configurations shown in Figures 3-8 through 3-15.

## 120V Inputs

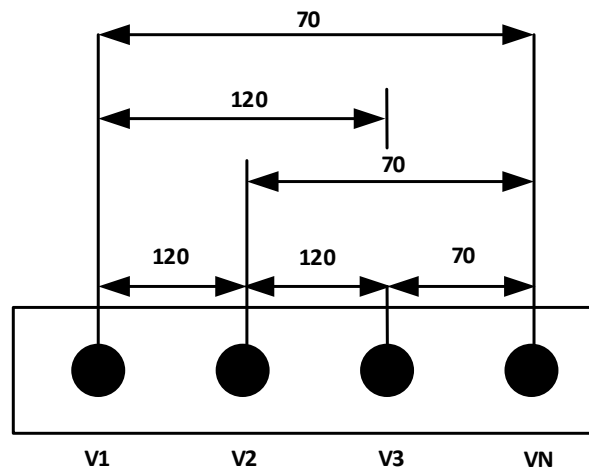

Figure 3-17

120V inputs usually imply use of a potential transformer (PT). The PT requires use of any of the four wiring configurations shown in Figures 3-7 through 3-10.

### 3.3.7 Current Input Connection

The PM17X PRO series provide two different types of connections to the current inputs:

- Using internal CT, connect the secondary winding of the switchgear CT to the current terminals of the device following the current flow polarity.
- Using external CT (HACS – High Accuracy SATEC Current Sensor), connect the HACS secondary winding to the current terminals of the device following the current flow polarity.

### 3.3.8 Wiring Diagrams

For AC input ratings, see “[Technical Specifications](#)” in Chapter 18.

The following wiring configurations are available in the meter:

Table 2: Wiring Characteristics

Wiring Configuration (See Basic Device Settings in Chapter 8)	Setup Code	Figure
3-wire 2-element Direct connection using 2 CTs	3DIR2	3-17
4-wire Wye 3-element direct connection using 3 CTs	4LN3 or 4LL3	3-18
4-wire Wye 3-element connection using 3 PTs, 3 CTs	4LN3 or 4LL3	3-19
3-wire 2-element Open Delta connection using 2 PTs, 2 CTs	3OP2	3-20
4-wire Wye 2½ -element connection using 2 PTs, 3 CTs	3LN3 or 3LL3	3-21
3-wire 2½ -element Open Delta connection using 2 PTs, 3 CTs	3OP3	3-22
4-wire 3-element Delta direct connection using 3 CTs	4LN3 or 4LL3	3-23
3-wire 2½ -element Broken Delta connection using 2 PTs, 3 CTs	3bLn3 or 3bLL3	3-24

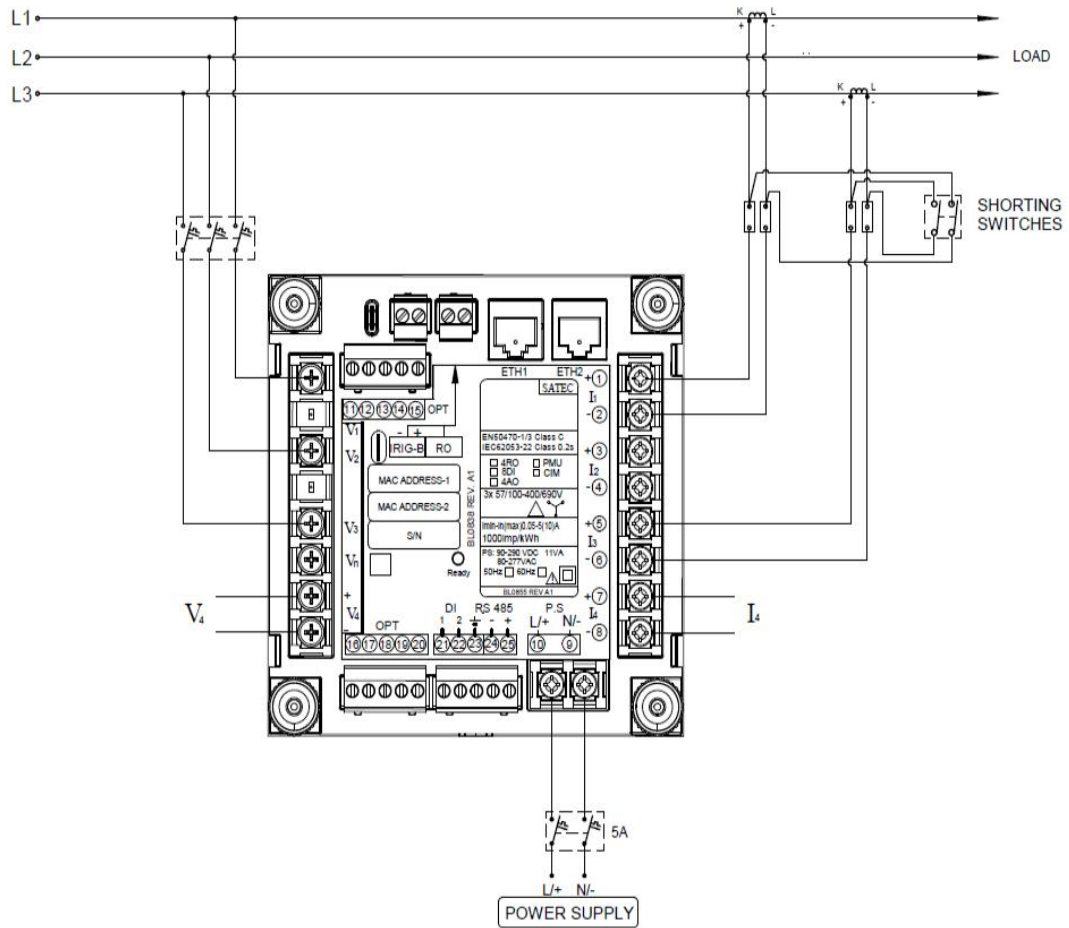

Figure 3-18 3 Wire 2-Element Direct Connection Using 2 CTs.

Wiring Mode = 3DIR2

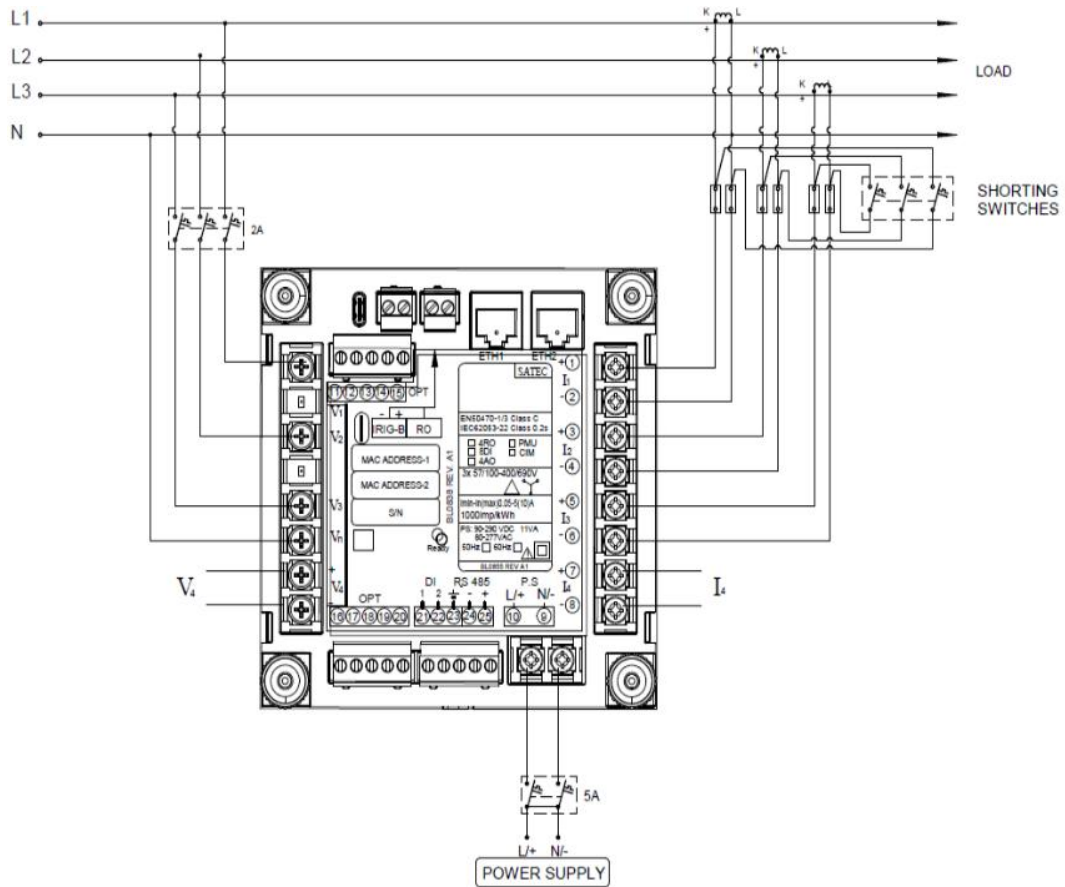

Figure 3-19 4-Wire Wye 3-Element Direct Connection Using 3 CTs.

Wiring Mode = 4LL3 or 4LN3

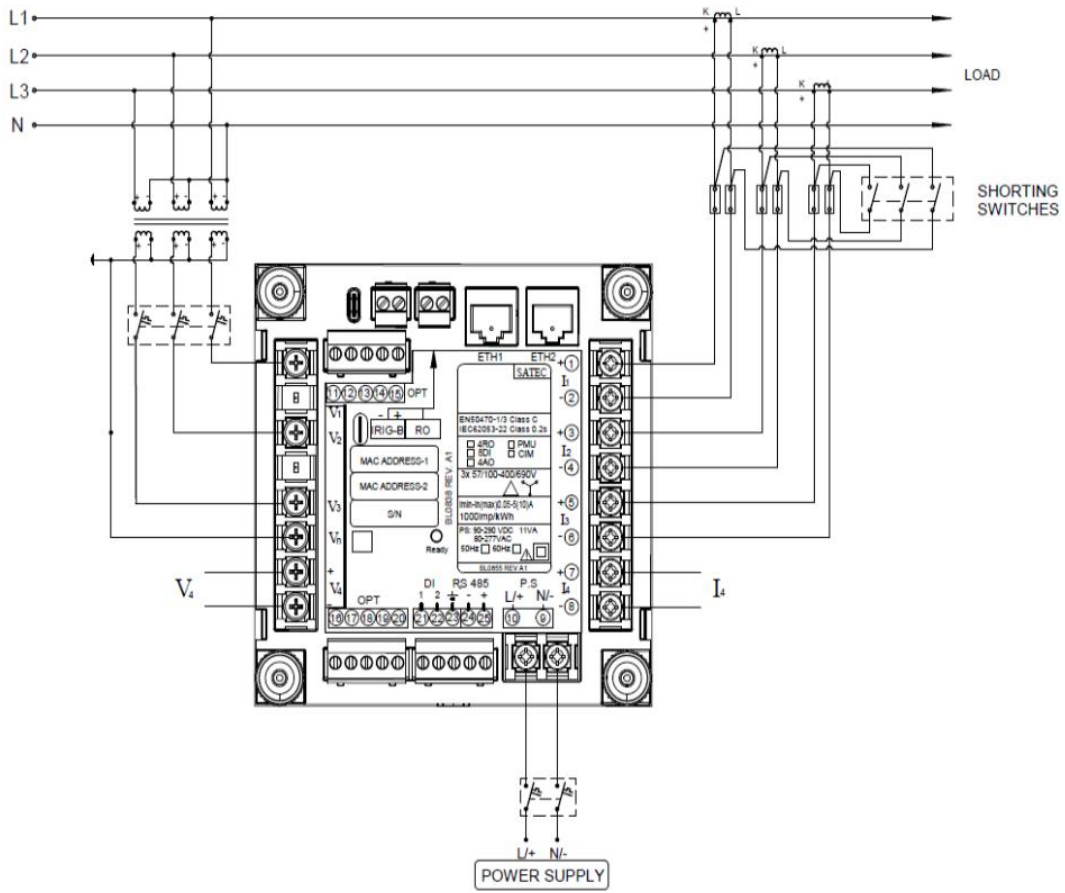

Figure 3-20 4-Wire Wye 3-Element Connection Using 3 PTs, 3 CTs.

Wiring Mode = 4LL3 or 4LN3

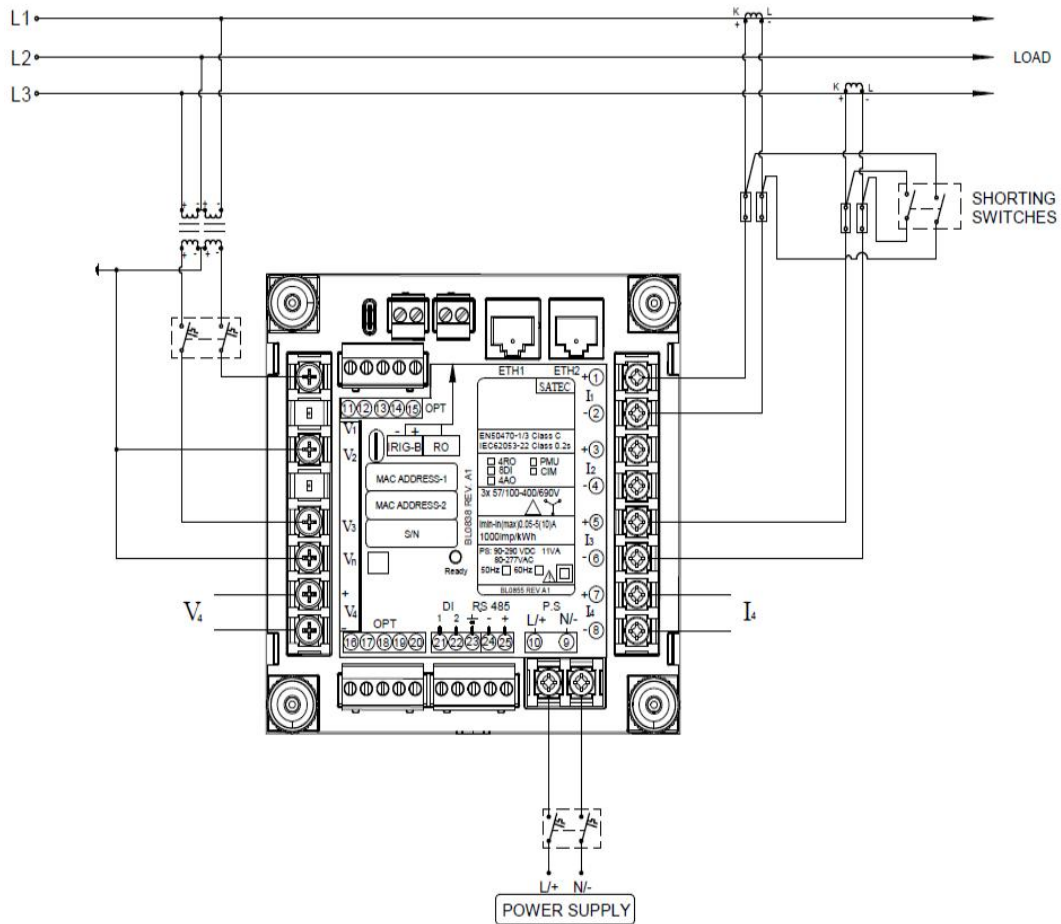

Figure 3-21 3-Wire 2 Element Open Delta Connection Using 2 PTs, 2 CTs.

Wiring Mode = 3OP2

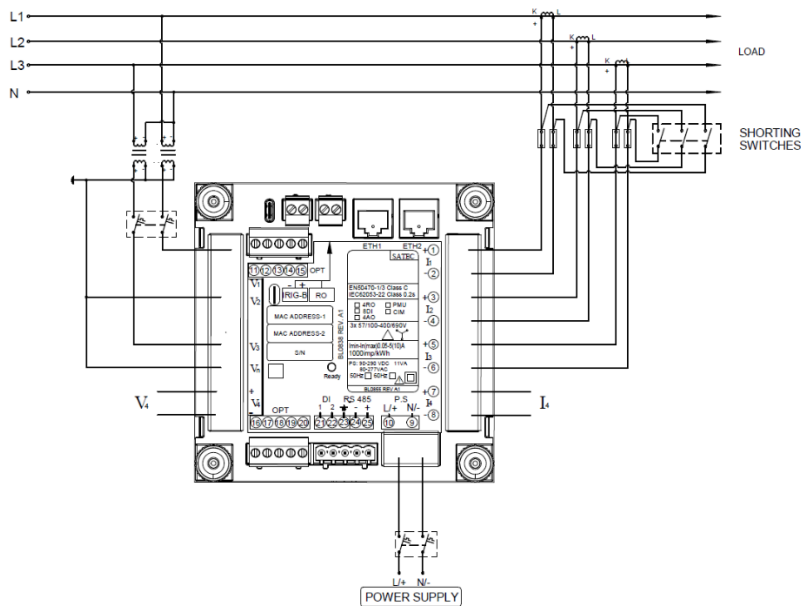

Figure 3-22 4-Wire Wye 2½ Element Connection Using 2 PTs, 3 CTs.

Wiring Mode = 3LL3 or 3LN3

This configuration provides accurate power measurements only if the voltages are balanced.

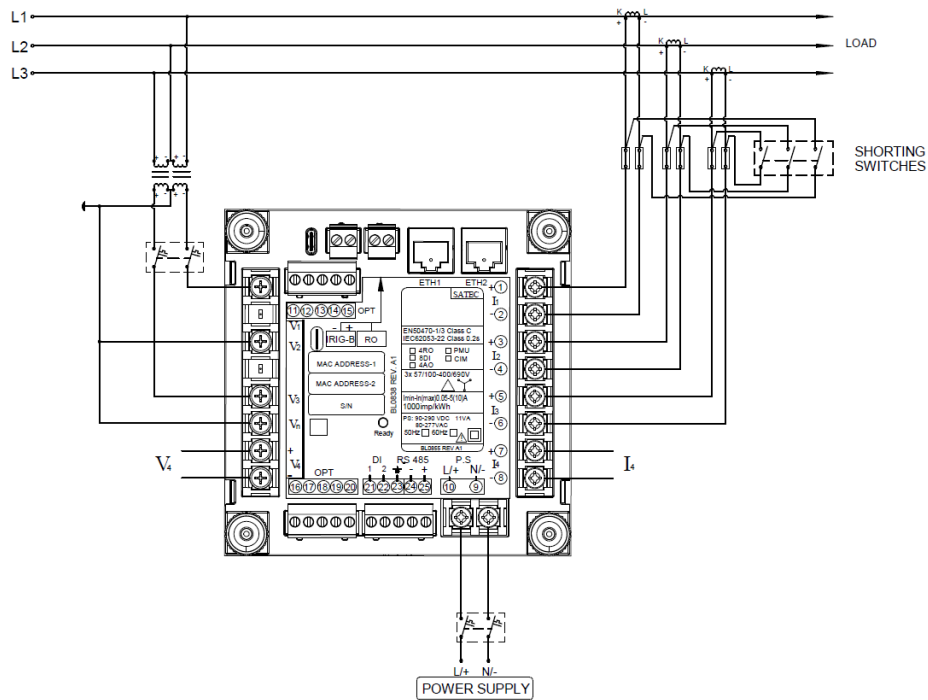

Figure 3-23 3-Wire 2 1/2 Element Open Delta Connection Using 2 PTs, 3 CTs.

Wiring Mode = 3OP3

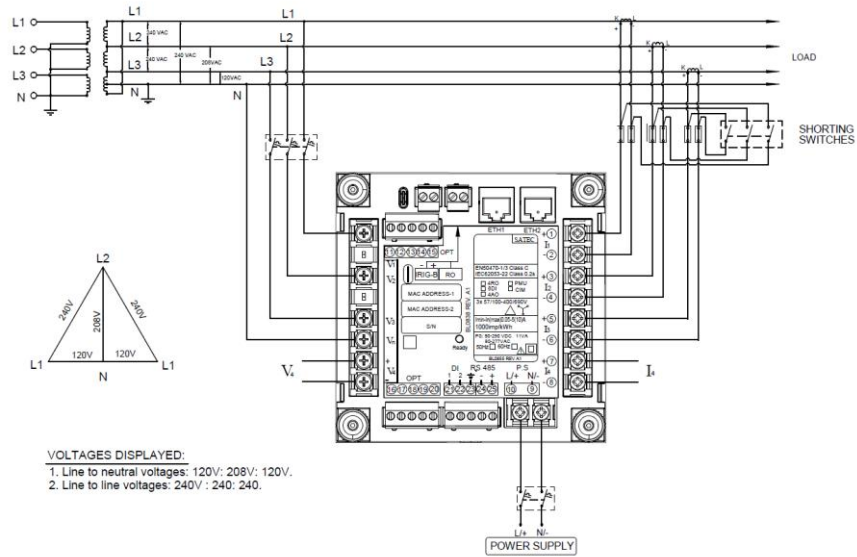

Figure 3-24 4-Wire 3 Element Delta Direct Connection Using 3 CTs.

Wiring Mode = 4LL3 or 4LN3

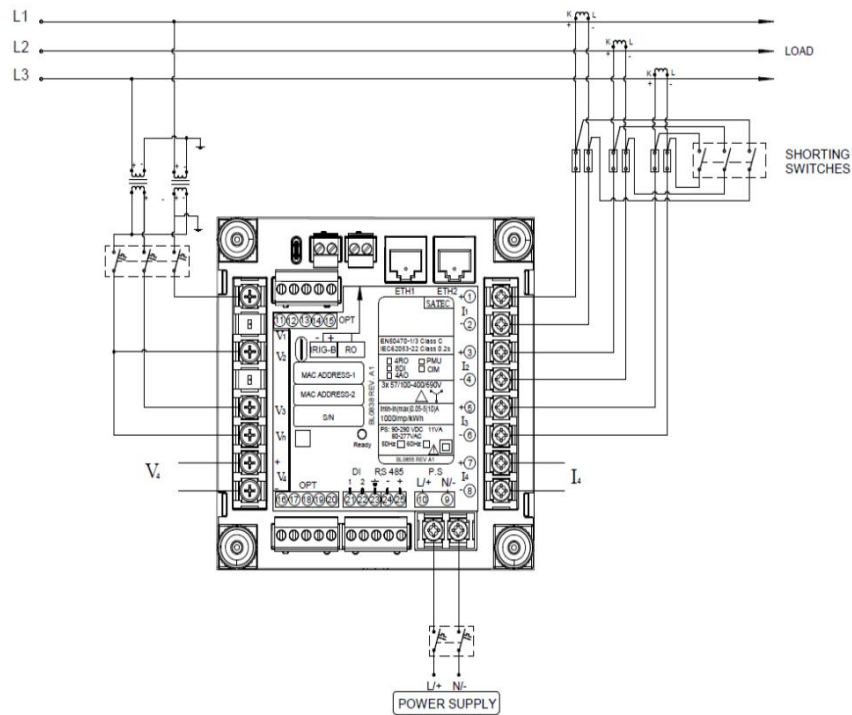

Figure 3-25 -4-Wire 2½ Element Broken Delta Connection Using 2 PTs, 3 CTs.

Wiring Mode = 3bLn3 or 3bLL3

### 3.3.9 DC voltage measurement

PM17X PRO enables measuring 1-4 independent DC sources via 3 independent DC voltage Inputs.

When the Pro device is used as a single DC meter V1 and I1 shall be used. V2 and V3 must be connected to GND.

When the Pro device is used as a multichannel DC meter. V1/I1, V2/I2, V3/I3 and V3/I4 serve as independent channels/meters.

PM17X PRO Measures up to 800V DC via direct connection to the Pro meter:

Measuring 1500V DC and 2500V DC systems is possible via the SATEC Voltage Ratio Module (VRM).

When using the VRM, it is recommended that the distance between the SATEC VRM and SATEC meter should not exceed 2 meters, using cabling featuring minimum 600V insulation.

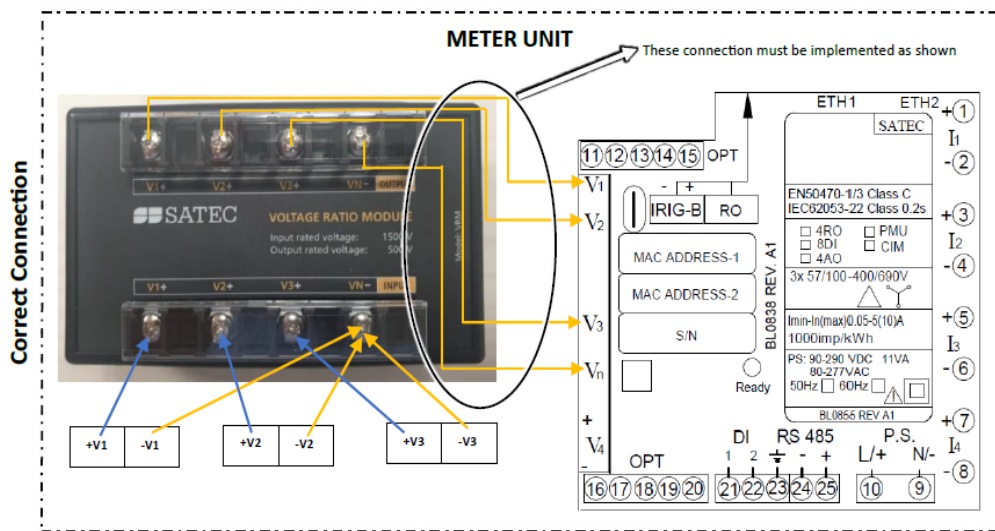

Figure 3-26 DC Voltage Measurement

Voltage Ratio Module Characteristics:

- Accuracy = 0.1%
- 3 Independent voltage inputs
- DIN-rail installation

When using the SATEC VRM, the correct ratio coefficient must be set with PAS software (“basic configuration” tab): “PT ratio” = 3.5

PRO - General Setup

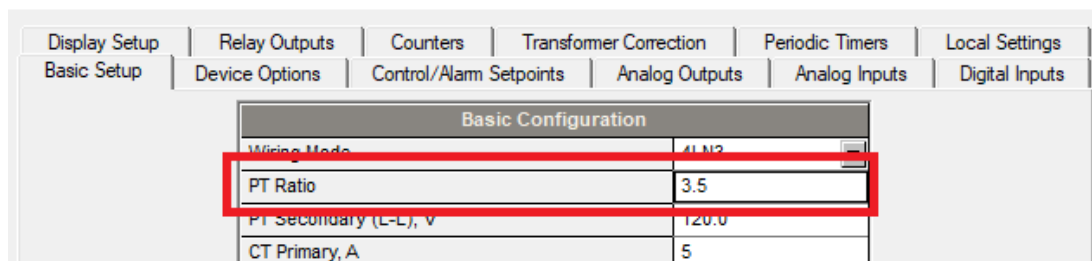

Figure 3-27

### 3.3.10 DC Current Measurement (Hall Effect Sensors)

PM17X PRO has 4 independent current inputs rated at 20mA nominal current, to which the user may connect standard hall effect sensors featuring 0-20mA/+20mA outputs.

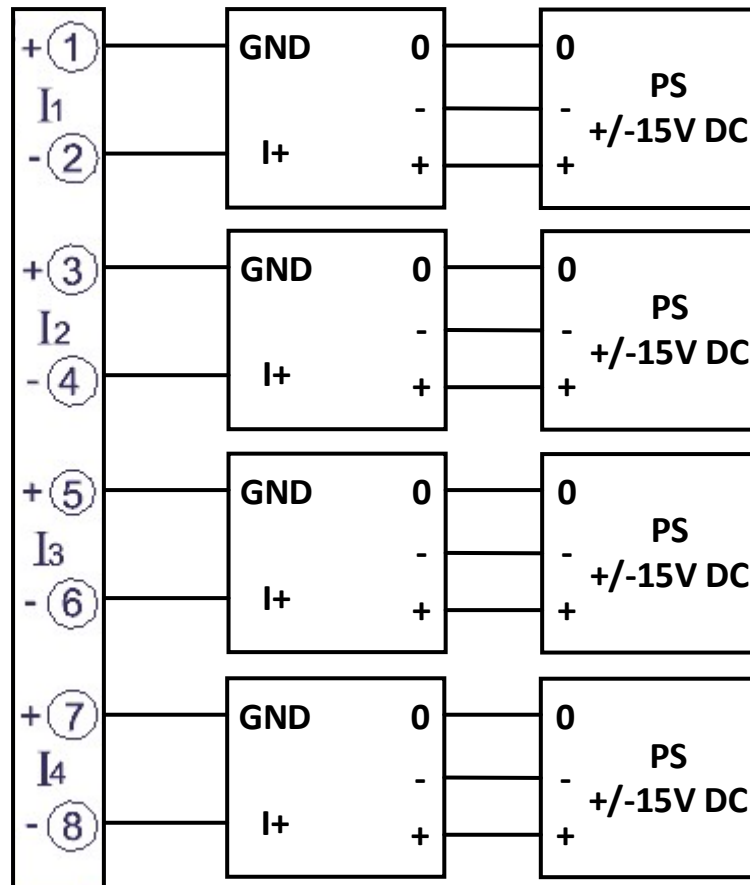

Figure 3-28

Notes:

- It is mandatory to use cabling featuring double insulation (600V) when connecting Hall Effect sensors to PRO series meters.
- It is mandatory to use a separate power supply for each sensor.

Requirements for power supply for Hall Effect Sensors:

- Double insulation
- No Ground connection permitted
- Overvoltage with-stand of 3kV or more
- Satec HEPS (Hall effect sensor power supply) or: 15V DC or +/- 15VDC (or 12VDC) power supply, depending on HSE type
- UL Listed

DC power is calculated with indication for power flow direction.

Energy is calculated for each channel separately (except for I4).

Typical Current measurement accuracy: better than 0.5% (depending on HES type)

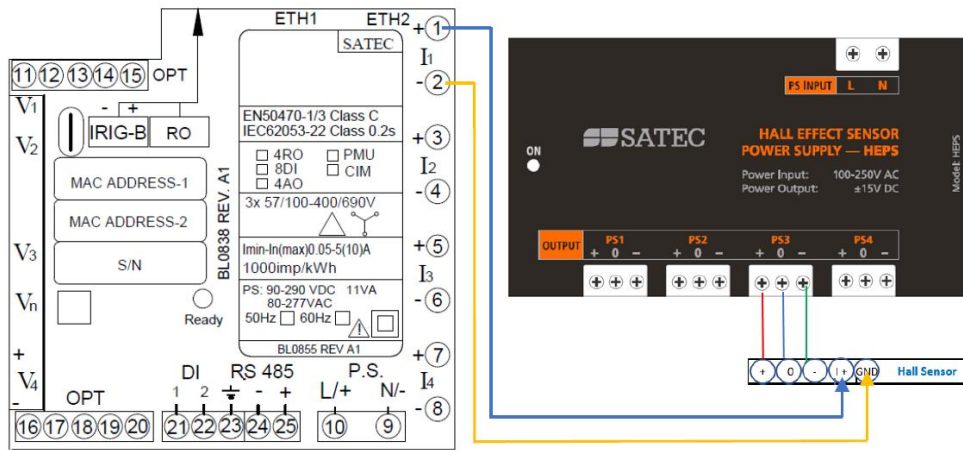

Figure 3-29

For I/O ratings, see “[Technical Specifications](#)” in Chapter 18.

## 3.4 I/O Connections

### 3.4.1 Relay Outputs

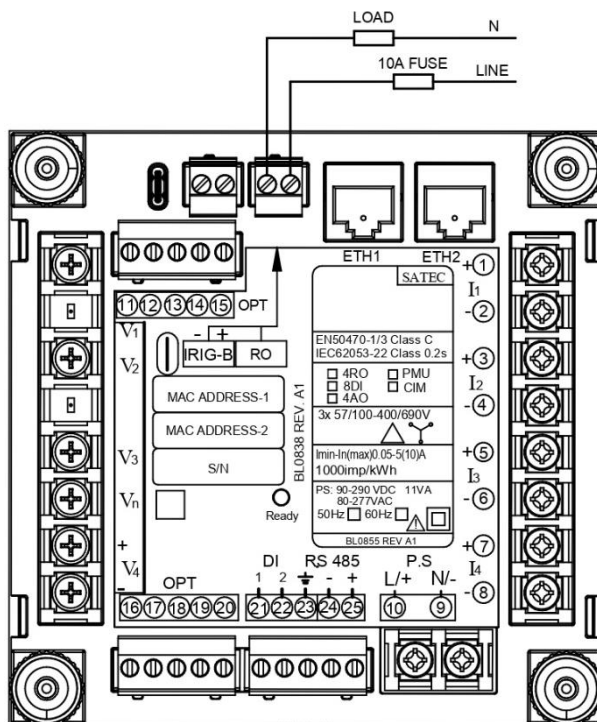

Figure 3-30 Relay Output Connection

### 3.4.2 Digital Inputs

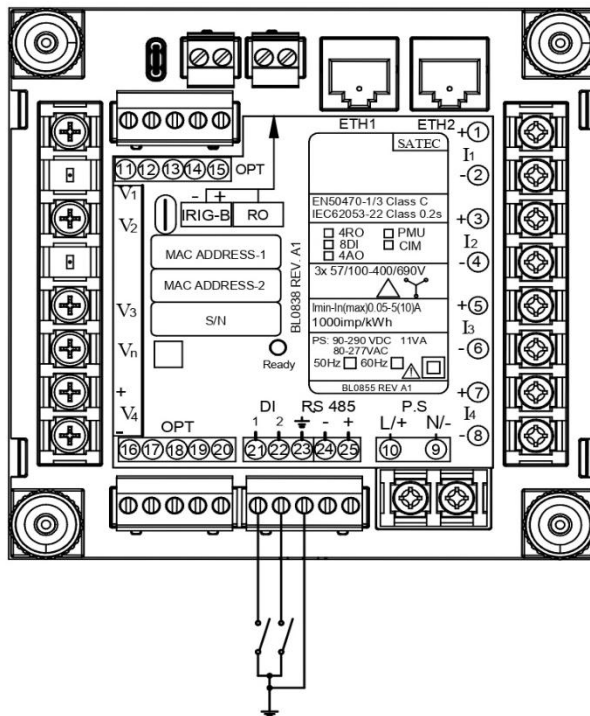

Figure 3-31 Digital Input Connection

## Chapter 4 Internal Optional Modules

### 4.1.1 4RO Module

The 4RO module has four electro-mechanic relays (EMR) or solid-state relays (SSR) outputs provided for energy pulsing, alarms, or remote control. One internal module can be installed during production.

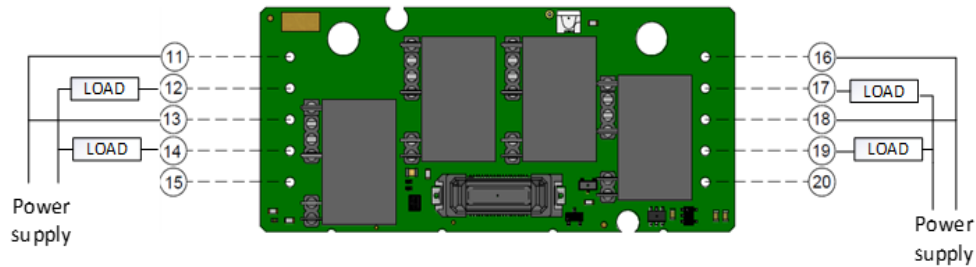

Figure 4-1 4RO Module Connection

### 4.1.2 8DI Module

Eight optically isolated status inputs are provided for status monitoring, pulse counting, external power demand period, and time synchronization. One internal module can be installed during production.

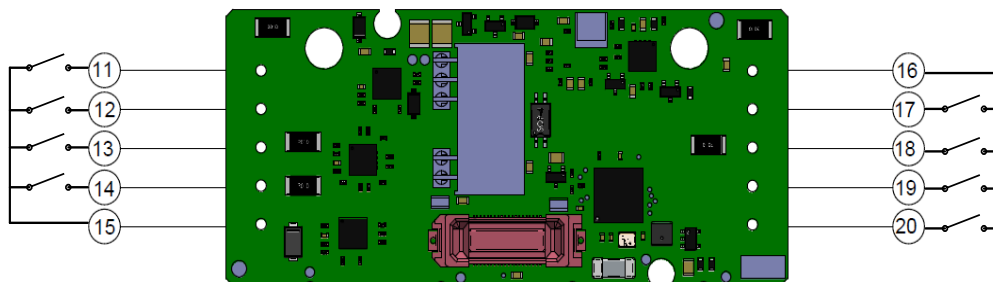

Figure 4-2 8 DI – Front view & Digital Input Connection – Dry contact model

In case of Dry contact module, the internal 24VDC power supply is operated.

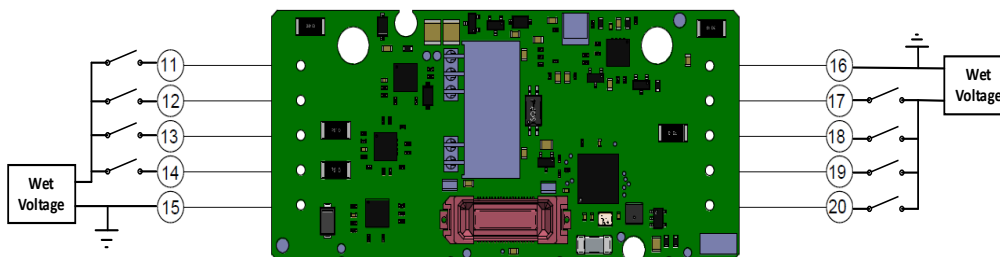

Figure 4-3 8 DI - Digital Input Connection – Wet contact model

In case of Wet contact module, the external power supply is operated: 24V, 48V, 125V, 250V. The wet contact source may have any polarity (or AC: 50/60Hz).

The Voltage Inputs must have the one common wire.

### 4.1.3 4DI/2RO Module

Four optically isolated status inputs are provided for status monitoring, pulse counting, external power demand period, and time synchronization. The 2RO module has two electro-mechanic relays (EMR) or solid-state relays (SSR) outputs provided for energy pulsing, alarms, or remote control. One internal module can be installed during production.

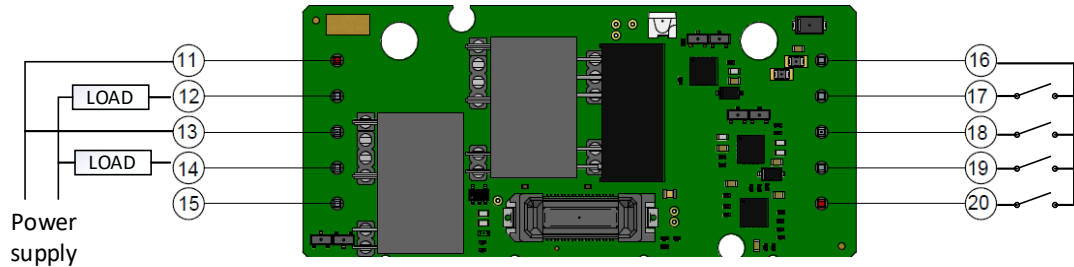

Figure 4-4 4DI/2RO DRY Contact/EMR

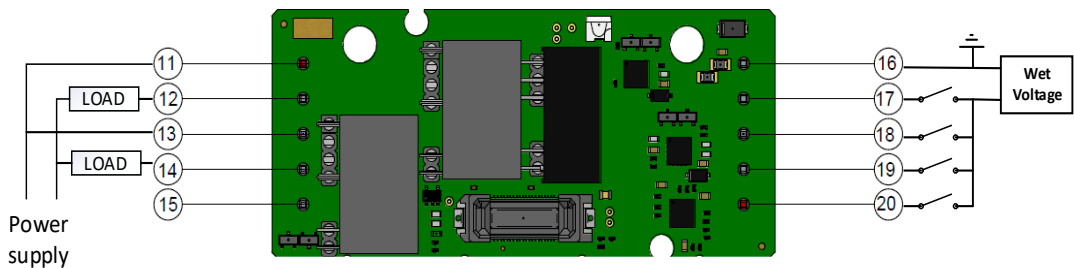

Figure 4-5 4DI/2RO WET Contact/SSR

### 4.1.4 4AO Module

The PM17X PRO 4AO optional module contains 4 analog output versatile channels that can output DC currents proportional to the measured analog quantities. All outputs are optically isolated and have an internal power supply.

The AO modules supports 0-1mA,  $\pm 1$ mA, 0-20mA, or 4-20mA (remotely programmed through PAS).

See chapter 9 for details.

All 4 outputs are configured for the same range.

Update time for analog outputs is 2-cycles (32 ms at @ 60Hz and 40 ms @ 50Hz).

One internal module can be installed during production.

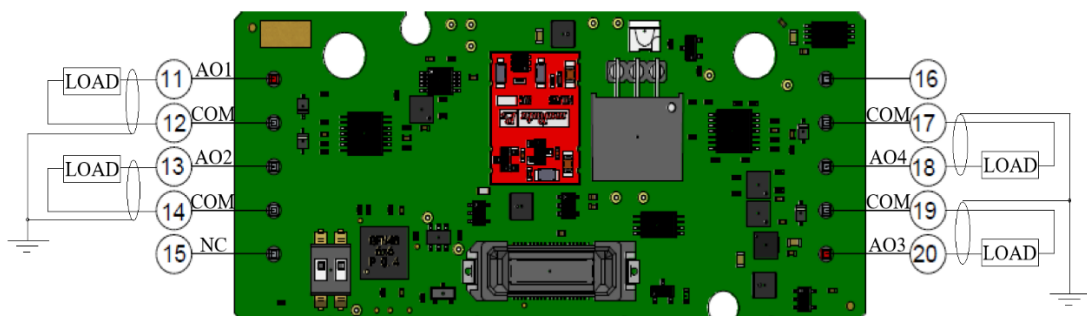

Figure 4-6 4AO module

### 4.1.5 Current Inputs Module (future)

### 4.1.6 PMU Module (future)

### 4.1.7 12/24V DC Input Power Module

The PM17X PRO is working as default using AC power.

The PM17X PRO might be ordered in a DC power supply input option.

The 24VDC module designed to provide the power supply ability of the meter in the low DC Voltage range.

Input Voltage range of PS 24VDC: 9-36 VDC.

Rating: 24VDC: 9-36 VDC

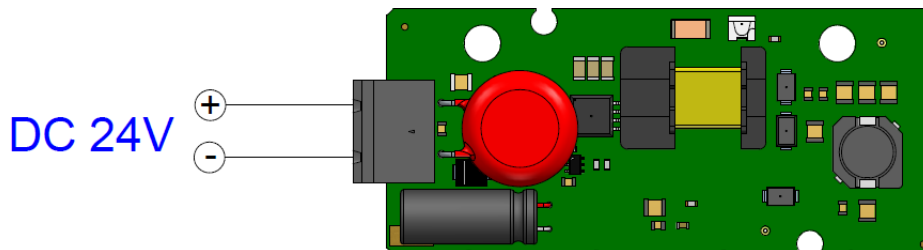

Figure 4-6 PS 24VDC Module Connection

Table 3: Wiring Characteristics

Terminals	Conductor Size			Torque [Nm]	Notes
	PRO model	Minimum AWG (mm <sup>2</sup> )	Maximum AWG (mm <sup>2</sup> )		
Aux. Power Supply Inputs L/+, N/- (AC-DC Type)	ALL	22 (0.5)	12 (2.5)	0.5-0.7	Use 600V insulated conductors Required crimped ferrule: Panduit (22AWG) F75-10-M Panduit (12AWG) F81-10-M
Aux. Power Supply Inputs +, - (DC-DC Type)					

## 4.2 Communications Connections

Several communication module options are available for the PM17X PRO:

- Built-in serial Communication COM: RS-485
- Built-in USB Device Communication: USB-C connector
- Built-in 2 x 10/100Base T ETHERNET Communication – Daisy Chain or double independent Ethernet ports: RJ-45 connector

A full description of the communication protocols is found in the PM17X PRO protocol guides that come with your meter.

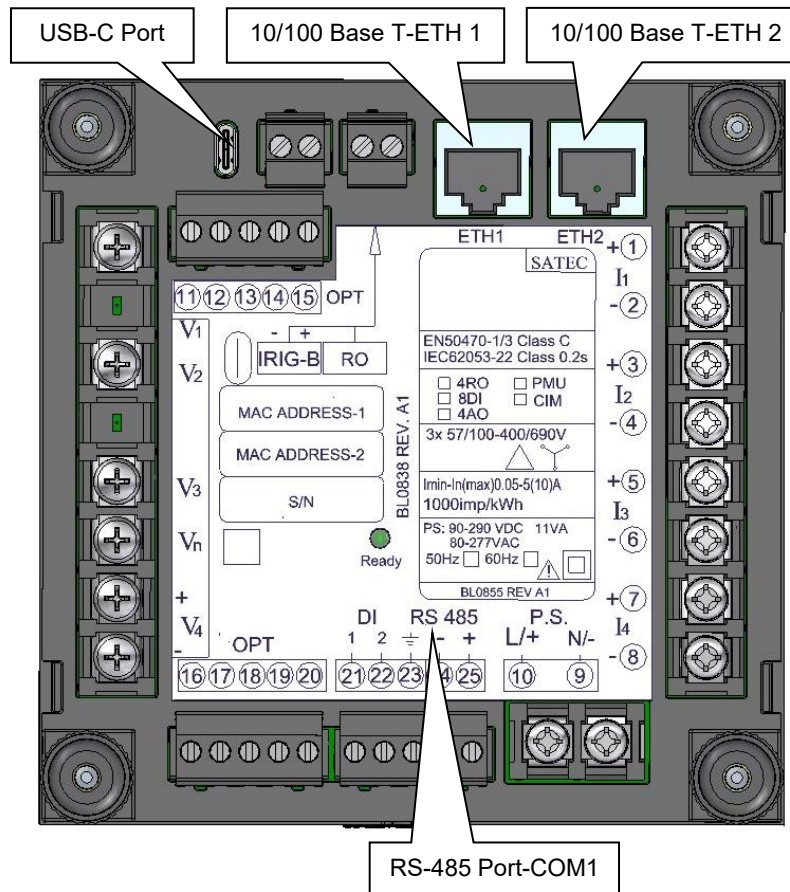

Figure 4-7 Communication ports location

### 4.2.1 RS-485 Connection

Built-in communication port

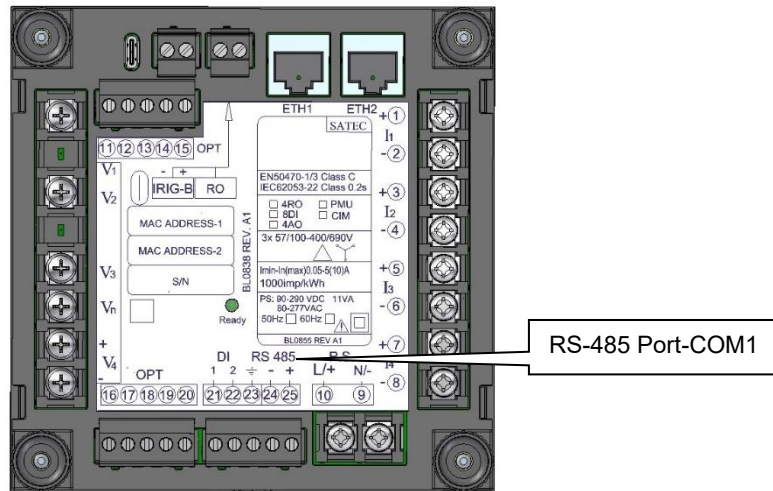

Figure 4-8 RS-485 2-Wire Connection

The connector is removable with three captured-wire terminals. +, - for data and GND for shield.

### 4.2.2 Ethernet Connections

The external equipment TERMINAL connection type is RJ-45

The type of equipment that might be connected to the TERMINAL as:

- PC or LAPTOP 10/100Base-T
- LAN HUB and/or Switch

The RATING of the insulation of the external equipment for use with the ETH port, shall comply according to Installation Category III for insulation to be suitable for SINGLE FAULT CONDITION.

#### ETHERNET Connection

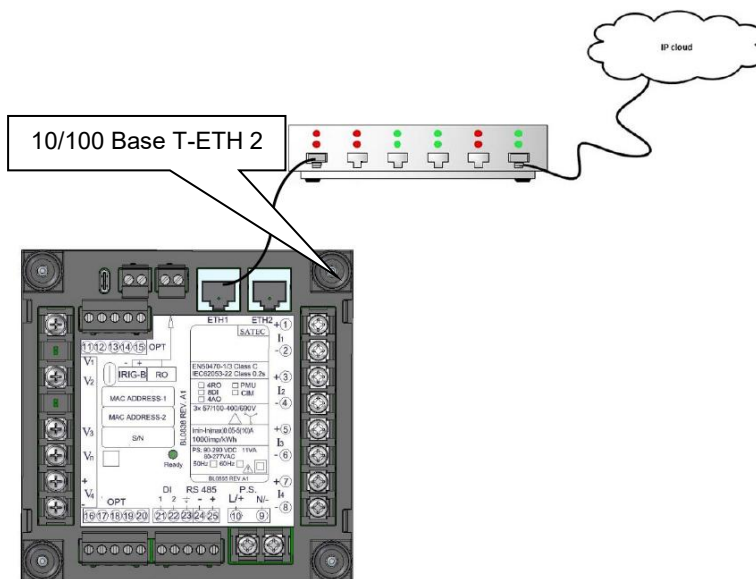

Figure 4-9 Ethernet Connection – RJ45 connection

### ETHERNET Daisy Chain Connection

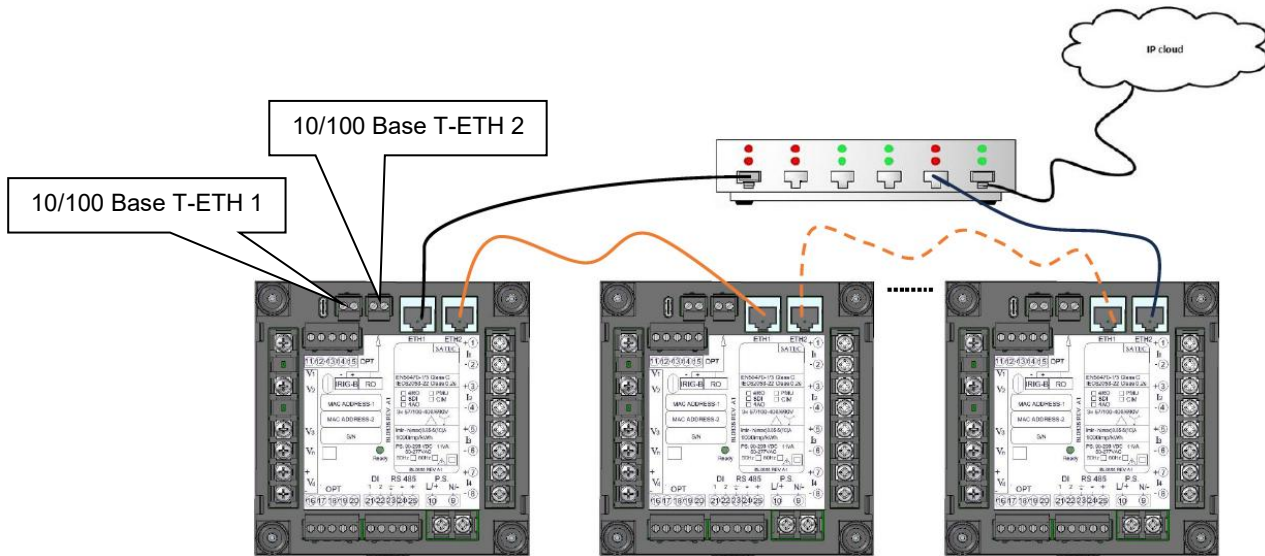

Figure 4-10 Ethernet Daisy Chain Connection with fall back (RSTP support)

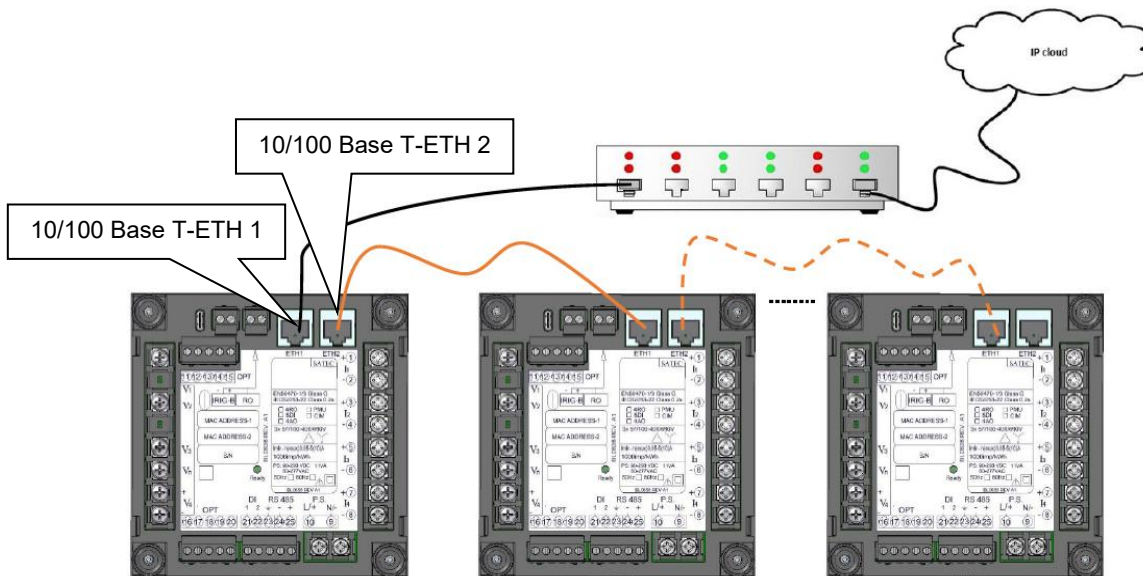

Figure 4-11 Ethernet Daisy Chain Connection with fall back (RSTP support)

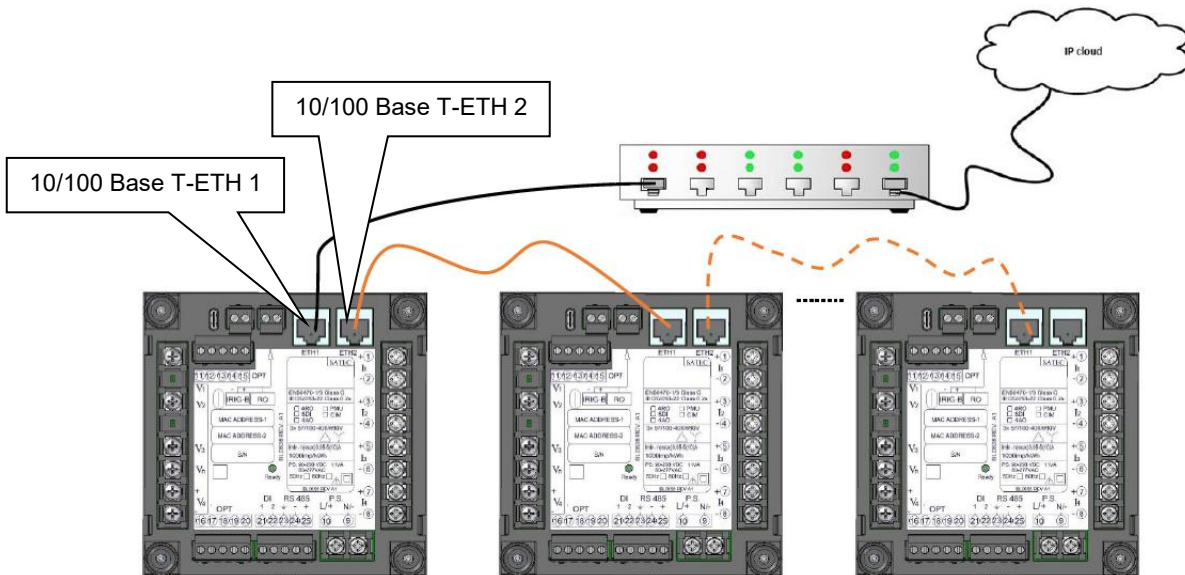

Figure 4-12 Ethernet Daisy Chain Connection without fall back

Double ETHERNET Connection

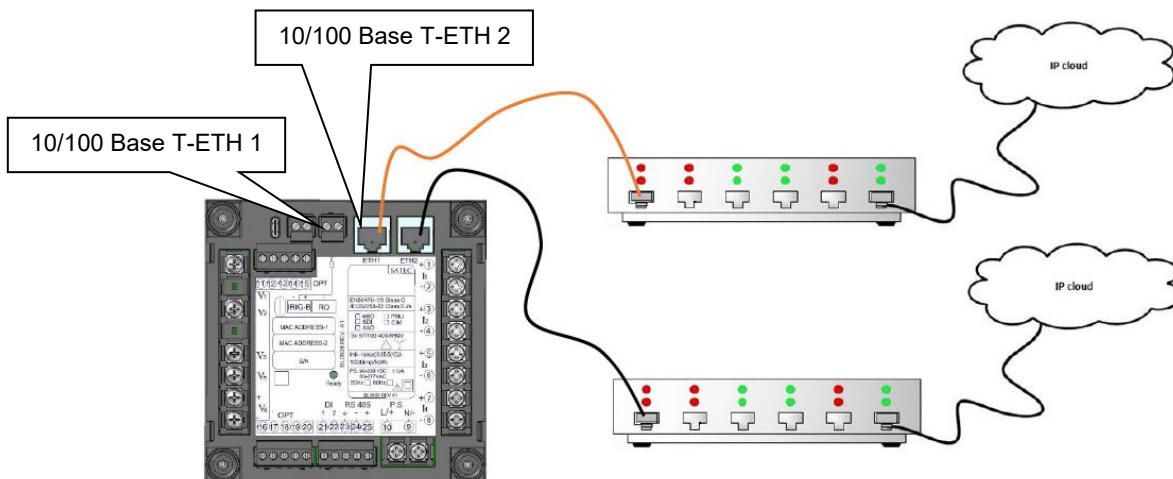



Figure 4-13 Double Ethernet Connection

### 4.2.3 USB Connection

 To prevent potential differences between the Personal Computer (PC) USB port and the PM17X PRO USB device port, it is recommended to use a galvanic isolated USB adaptor before connecting the PM17X PRO USB port to a Personal Computer (PC), or to use battery powered PC.

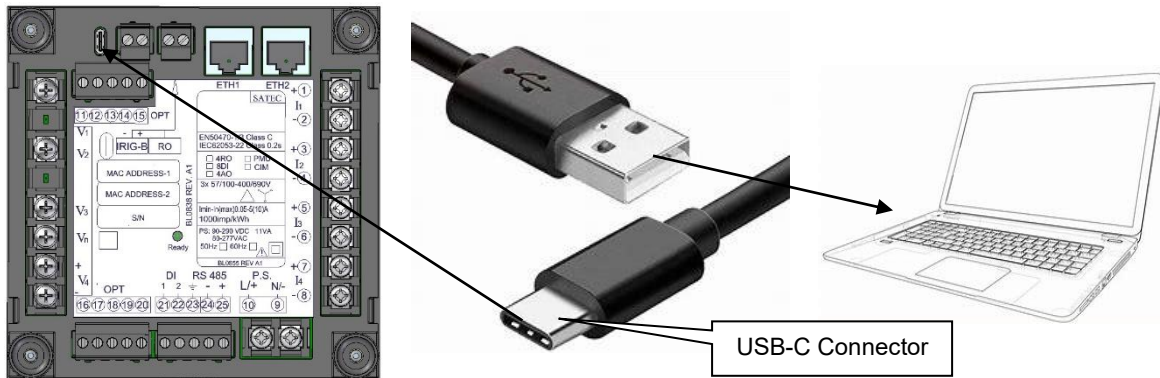

Figure 4-14 USB connection – USB-C connection

## Chapter 5 Operating with the PM17X PRO

### 5.1 Communicating with the PM17X PRO

Communication with the PM17X PRO can be established independently and simultaneously through any communications port using the support PAS program supplied with the device or user application software. All communication ports are slave ports and have factory-preset parameters, such as baud rate, data format, and communications protocol that can be easily changed whenever desired.

#### 5.1.1 COM Serial Communication (Standard)

The PM17X PRO has a standard serial communication port for communicating with the master workstations, RTUs, PLCs or PAS™@ PCs, and with an optional remote display. The serial port operates in the RS-485 two-wire mode. Local programming and upgrading the device firmware can be established by the communication port.

The port is optically isolated and can operate at baud rates up to 115200 bps. The port can be set up for any communication protocol supported by the PM17X PRO independently. The port is factory preset to 19200 bps, 8-bits/No-parity data format, and programmed for the Modbus RTU protocol.

The COM2 port has different connection terminals and is intended for communication with the LED display unit.

See [Communicating through a Serial Port](#) in Chapter 9, for information on how to set up serial ports in your device. For wiring diagrams, refer to Communication Connections.

#### 5.1.2 Ethernet Ports

One or two 10/100Base-T Ethernet ports provide a direct connection of the PM17X PRO to a local area network through the TCP/IP protocols. The device has three onboard TCP servers configured for the Modbus/TCP (at TCP port 502), DNP3.0/TCP (at TCP port 20000) and IEC 60870-5-104 (at TCP port 2404) communications. The TCP servers can support up to 10 simultaneous connections with MODBUS/TCP, DNP3.0/TCP and IEC 60870-5-104 client applications.

Connection through the Ethernet port does not require device identification. The PM17X PRO responds to any device address and returns the received address in the response message.

The two Ethernet ports can either be configured for separate and independent ethernet port or used for daisy chain configuration.

#### Note

To provide simultaneous file services for all ports, the PM17X PRO keeps independent file pointers for each communications port. For a TCP port, the PM17X PRO holds separate file pointers for each active TCP socket. The TCP server automatically closes a connection if a socket is idle for more than 5 minutes. There is no guarantee that a new connection is established at the same socket, so do not make any assumptions regarding the current file status when starting a new connection from your application.

Always initialize a file pointer to a record from where you expect to begin reading a file. For more information, see "File Transfer" in the PM17X PRO MODBUS Communications Guide.

#### 5.1.3 USB Port (Standard)

A USB node port is intended for local communications with the support PAS software. It is directly connected to your PC's USB port using the supplied USB cable. The USB communications does not require any settings. Just connect your PC to the PM17X PRO USB port and install the supplied USB driver. The USB communications is ten times faster than the serial communications can provide at a maximum baud rate.

#### 5.1.4 Using PAS

PAS is the support software supplied with the PM17X PRO that gives the user basic tool for programming the device, performing remote control operations, monitoring real-time measurements, retrieving and analyzing historical data files, reviewing power quality reports, and more.

PAS can communicate with the devices through any PM17X PRO port using the MODBUS RTU, MODBUS ASCII and DNP3.0 protocols. For information on installing and using PAS, Chapter 9 "[Using PAS Software](#)".

## 5.2 Device Inputs

### 5.2.1 AC (or DC) Inputs

The AC/DC voltage and current input terminals are connected to the internal device circuits through high impedance input voltages and transformers input current that isolate the device from external wiring.

### 5.2.2 Voltage Inputs

The device has four high-impedance voltage inputs (direct 690V RMS phase-to-phase voltage, ×140% overload). Voltage channels are designated as V1 through V4 and Vn. The secondary voltage rating and primary to secondary voltage ratio (PT ratio) of the external potential transformers must be specified in your device to provide correct voltage measurements. For more information on specifying voltage input ratings in your device, see [Basic Device Settings](#) in Chapter 8.

The secondary rating of the voltage inputs is used as a reference for calculating thresholds for the power quality triggers.

### 5.2.3 Current Inputs

The device is provided with current input transformers with either 5A or 1A rated current in the standard model.

For more information on specifying input ratings in your device, see [Basic Device Settings](#) in Chapter 8.

### 5.2.4 Sampling

8 AC channels (4 voltages and 4 currents) are continuously and simultaneously sampled at a rate of 256 samples per cycle (12.8 kHz at 50Hz or 15.36 kHz at 60Hz).

The sampling rate is precisely synchronized with the power frequency. The reference frequency signal is taken from one of the phase voltage inputs V1-V3, band-pass filtered, and then sampled at 12.5 MHz providing a 0.0004% cycle measurement error.

### 5.2.5 Waveform Tracing

The sampled waveforms are stored to the circular trace buffer whose depth is sufficient to provide up to 20 pre-fault cycles for the waveform recorder. The waveform recorder is synchronized with the sampling circuitry and can store unlimited number of post-event cycles. The length of the captured waveforms is only restricted by the size of the allocated logging memory.

### 5.2.6 Digital Input

The PM17X PRO can monitor 2 digital inputs in the device.

The digital inputs are sampled at a rate of 16/20 (60/50 Hz) samples per cycle and synchronized to the AC sampling circuitry. This gives time stamping of the input transitions with a 1-ms resolution.

The digital input has a programmable debounce time from one to 100 milliseconds in groups of two inputs. Each input can be independently linked to any device counter, Energy/TOU system register, and setpoints.

## 5.3 Device Outputs

### 5.3.1 Relay Output

The PM17X PRO provides one on-device relay output (SSR). Rated at 0.15A/24V AC/DC, 1 contact (SPST Form A).

The following table shows timing characteristics of the relays and their expected lifetime.

Characteristic	Form A Relays
Galvanic isolation	4000V AC 1 min
Operate time	1 ms max
Release time	0.25 ms max
Update time	1 cycle

The relay is programmable and operates in latched, unlatched, pulse or KYZ mode.

Relay operation can be inverted so that the relay is energized in its non-active state and de-energized when it is operated. This mode, known as “failsafe” mode, is used for signaling purposes to send alarms when the device is not operational either due to a fault or due to loss of power.

### 5.3.2 Latched and Unlatched Operation

Latched and unlatched mode of operation concerns local relay commands issued from the control setpoints.

In unlatched mode, a local setpoints command sent to the relay is automatically cleared; the relay is released when all setpoints linked to the relay return to non-operated state.

In latched mode, the operated relay is not released automatically when the conditions that caused the relay to operate are no longer present. To release a latched relay, an explicit release command must be sent either from a separate setpoint, or through communications. If the relay is locked in the operated state by a remote command, the local release command only clears the internal latch and the relay stays in operated state until the remote command is removed.

### 5.3.3 Pulse and KYZ Operation

Pulse mode causes a relay to produce a pulse with a predefined duration in response to a local or remote relay command. After a pulse is expired, the command is automatically cleared and the relay is held up in released state for at least pulse width time before the next command is accepted.

The programmable pulse width is selected from 10 ms to 1 sec. The device scans all relays in 1/2-cycle time intervals. This means that the actual pulse width is a multiple of the 1/2- cycle time rounded to the nearest larger value. The programmable pulse width does not include the relay operate and release times.

In KYZ mode, every operate command changes the present state of a relay to the opposite state producing a transition pulse, and the relay is held up in this state for at least pulse width time before the next command is accepted. KYZ mode is commonly used with Form C relays to signal pulses by alternation of the two contact pairs.

Pulse and KYZ relays can be directly linked to the internal pulse sources to output energy or time interval pulses.

### 5.3.4 Remote Commands

A remote operate command forces a latched or unlatched relay to move to its active state. The relay is held in active state until the command is removed by a remote release command. The remote release command also removes the local commands that hold a latched relay in active state.

A remote operate command sent to a pulse or KYZ relay forces the relay to produce a pulse or changes its state. A remote release command sent to a pulse or KYZ relay has no effect since the operate command is cleared automatically for these relays.

### 5.3.5 Retentive Relay

Latched relay can be set to operate in retentive mode. Retentive mode affects the behavior of the relay after loss of power.

After restoring power, all non-retentive relay is in inactive state until local conditions are reevaluated. All active remote commands for non-retentive relays are cleared.

Retentive relay retains its status after restoring power, and all active remote commands that were issued before loss of power are still effective.

### 5.3.6 Critical Faults

When a critical error is detected by the device diagnostics, the relay is released regardless of its operation mode and all remote relay commands are removed.

## Chapter 6 Sensors

### 6.1 High Accuracy Current Sensors

All HACS have a built-in automatic protection circuit for maximum safety, eliminating the need to use shorting bars. HACS CTs are compatible with the HACS version meters, which are manufactured with corresponding unique current inputs.

- **Ultimate Accuracy:** Acting as a primary CT, with a product range of up to 3000A, there is no need for further/external CTs for measurement. These CTs feature milliamp outputs, feeding directly into the meter, making it a “one-CT” system, thus considerably increasing accuracy.
- **Ultimate Safety:** Featuring an internal electronic switch, providing an automatic protection circuit, these CTs prevent fire hazards regularly associated with disconnected CT outputs. This also saves costs, by making the installation of shorting bars unnecessary.
- **Remote Metering:** The milliamp output mentioned is also of very low burden, enabling running wiring for metering loads up to 200m away, without any compromise to accuracy.
- **Accuracy:** Solid Core: 0.1% / Split Core: 0.5%.
- All HACS are supplied with 8ft / 2.5m cable. Maximum cable length: 650ft / 200m.



Figure 6-1

## 6.2 RS5 Current Sensor

The scheme of RS5 sensor connection is the following. The primary connection of RS5 should be done to 5A line.

CT Primary current in PAS should be set as the rated current of the primary high voltage CT. For example, if CT is 600/5 and RS5 is installed after that CT, then we should set 600 A as CT Primary current.

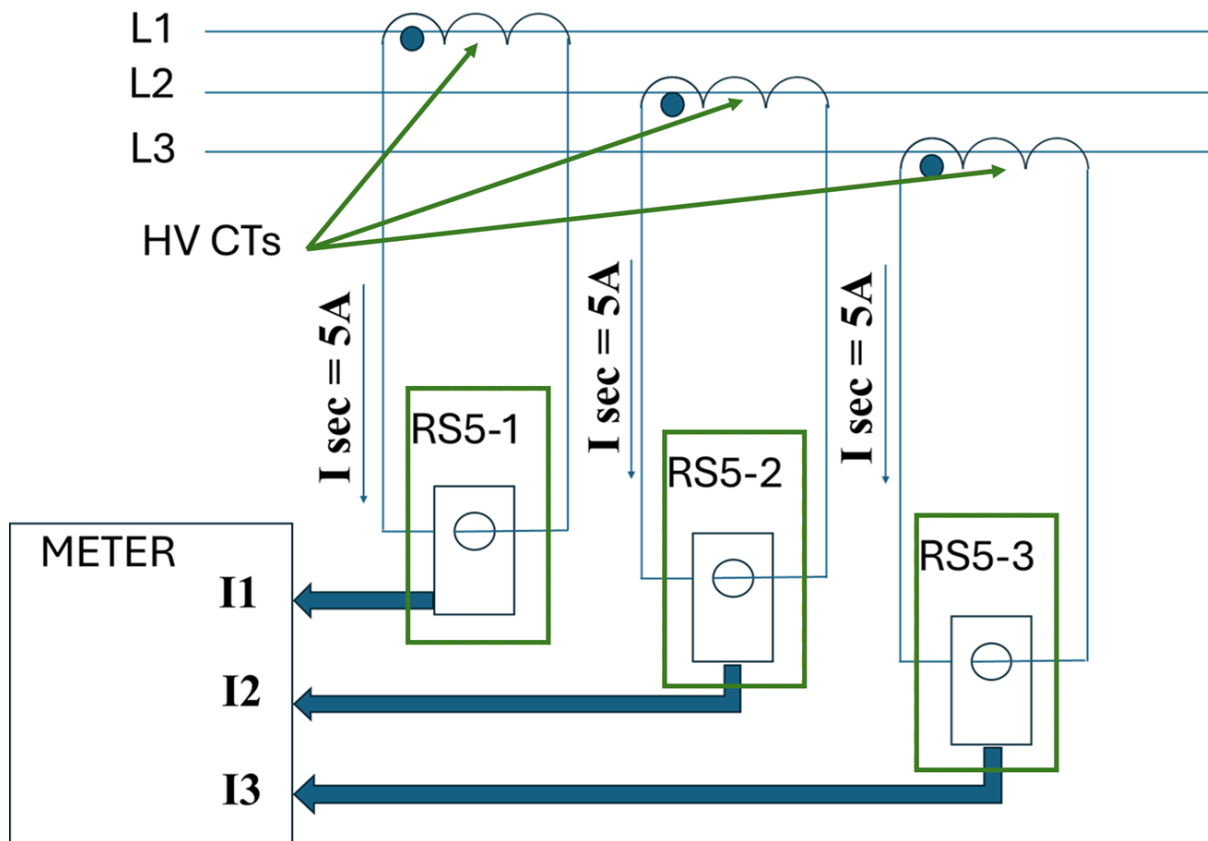

Figure 6-4. RS5 connection diagram

## 6.3 Medium voltage sensor interface

SATEC offers a version of the PM17X PRO designed to interface with LPVT (ABB's KEVA/ KEVCD) medium voltage sensors according IEC 61869-11.

This unique family of products is a range of extremely compact sensors. The range includes voltage sensors such as KEVA. The device is also compatible with combined sensors. The products feature RJ45 3,25V/ $\sqrt{3}$  outputs, designed for interfacing ABB digital protection relays.

SATEC's concept utilizes this interface to piggyback on these existing sensors and their output for highly accurate power metering. ABB sensors in chain with the PM17X device fulfill the requirements of the accuracy class 0.5 (Standalone PM17X's PRO itself fulfills Class 0.2S for kWh, per IEC 62053-22) and provide a power quality profile of the network in the range of below mentioned limits\*.

Adopting this concept also saves considerably on the need for erecting extra expensive metering cubicles, with all involved equipment (MV CT and PT).

\* - When using the ABB current sensors maximum measurable individual harmonic is the 21st order harmonic for 50HZ and the 18th order harmonic for 60HZ (1050Hz).

### 6.3.1 LPVT/LPCT sensor interface

The PM17X versions for interfacing the LPVT/LPCT sensors are equipped with 6 RJ45 inputs (figure below), two for each phase: current + voltage, or making use of just one socket, in case of a combined sensor.

The sockets for each phase are interchangeable between voltage and current, identifying the nature of the input.

In case of combined sensor, either socket (per phase) will read the combined outputs.

However, phases are NOT interchangeable and must be kept separate.

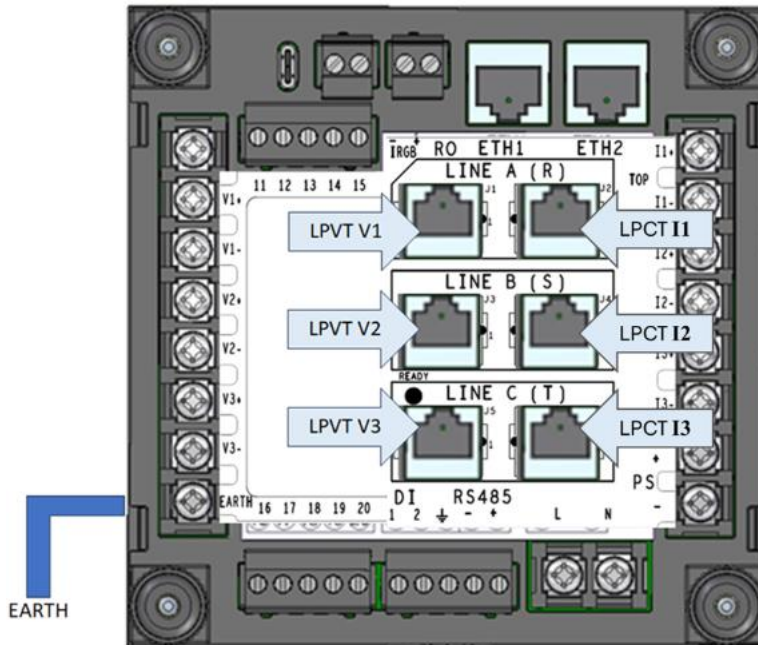

Figure 6-3. LPVT/LPCT connection diagram

**Note:** The voltage inputs (screws) V1 – V3, Current inputs I1-I3 (screws), PS +/- are not connected in this option

### 6.3.2 LPVT/5A sensor interface

The PM17X versions for interfacing the LPVT/5A measuring interface are equipped with 6 RJ45 inputs (figure 6-4, below), two for each phase. In this type of interface, we use only voltage sensor connection (LPVT). Two RJ45 connectors per each phase are identical. The customer may use one of them per each phase. The 5A current input is medium Voltage current transformer secondary current wire connection. (this connection is similar as standard 5A meter type connection).

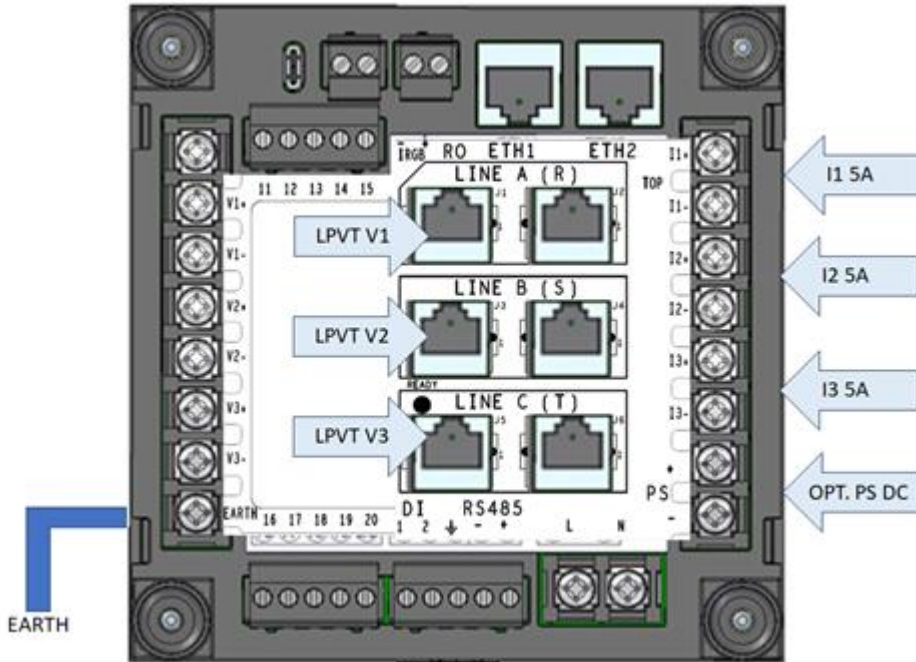

Figure 6-4. LPVT/5A connection diagram

**Notes:** The voltage inputs (screws) V1 – V3, PS +/- are not connected in this option

I1-I3 shall be connected as been seen on Figure 6-2

All current wires should be connected to the current inputs with screws shown on the image above using appropriate ferrule shown below. This crimp connection provides reliable contact.



Figure 6-5. A ferrule required for 5A secondary wires connection

### 6.3.3 LPVT/RS5 sensor interface

The PM17X versions for interfacing the LPVT/RS5 measuring interface are equipped with 6 RJ45 inputs (figure 6-4, below), two for each phase. In this type of interface, we use only voltage sensor connection (LPVT). Two RJ45 connectors per each phase are identical. The customer may use one of them per each phase. The RS5 current input is secondary wires of RS5 CT connection. RS5 CT is connected to medium Voltage current transformer secondary current. (The detailed explanation of RS5 CT Installation see in the corresponding chapter).

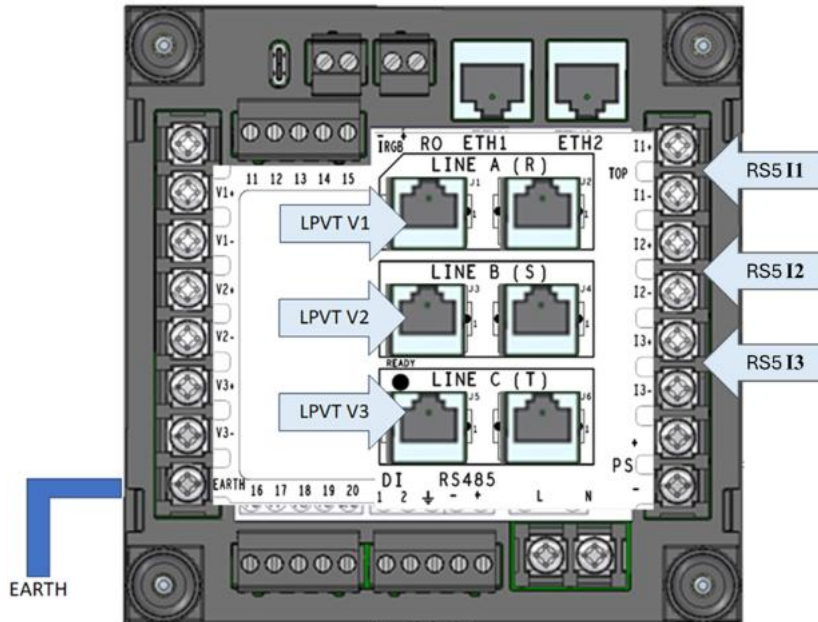

Figure 6-6. LPVT/RS5 connection diagram

**Notes:** The voltage inputs (screws) V1 – V3, PS +/- are not connected in this option

I1-I3 shall be connected as been seen on Figure 6-3

All RS5 secondary current wires should be connected to the current inputs with screws shown on the image above using appropriate ferrule shown below. This crimp connection provides reliable contact.



Figure 6-7. A ferrule required for RS5 secondary wires connection

## 6.4 Grounding

For safety reasons and accuracy, both the meter and sensors MUST be grounded:

- The EARTH wire must be at least 4 mm<sup>2</sup> square section connect to dedicated screw as shown on Figure 6-8.
- Each cable connected the sensor to RJ45 interface should be shielded.

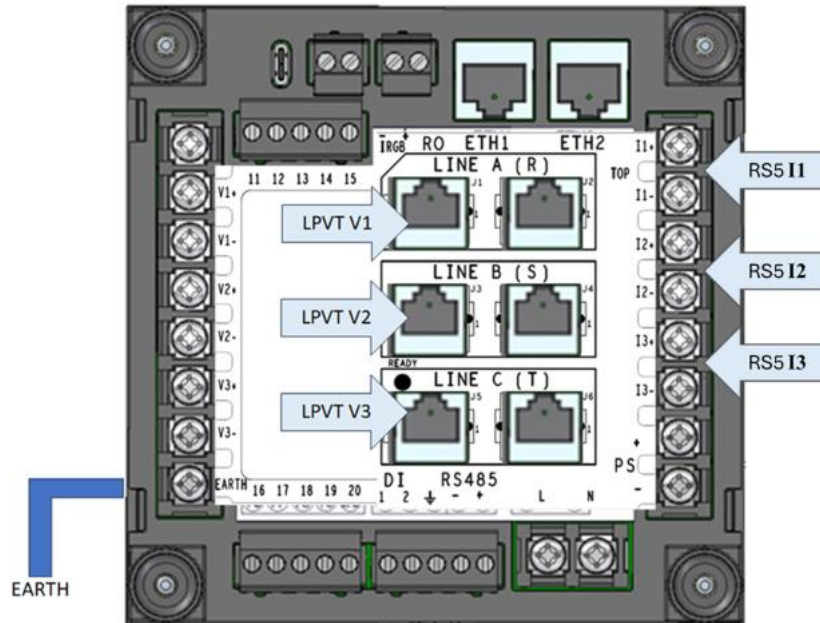

Figure 6-8. Connection diagram

Grounding wire (Earth) should be connected to the corresponding terminal with screws shown on the image above using appropriate ferrule shown below. This crimp connection provides reliable contact.



Figure 6-9. A ferrule required for grounding wire connection

## Chapter 7 Configuring the PM17X Analyzer

The LPVT sensors are characterized by current and voltage ratios that must be configured in the analyzer to afford correct readings.

Likewise, each individual sensor is characterized and marked with correction parameters for amplitude and angle (figure 7-2) which must be set as well in the analyzer.

Please download SATEC's PAS engineering software for easy device configuration. The download and the most recent .exe file, and other related material can be found in the following link: <https://www.satec-global.com/power-analysis-software>

### 7.1 Configuring current and voltage ratio

Open PAS software, connect to the meter and the go to  
Meter Setup -> General Setup -> Basic Setup  
where you will find the needed parameters (figure 7-1)

Voltage ratio: set *PT ratio* at 56.9

Current ratio: set Primary Current, A in accordance with the sensor type (table 4) being interfaced:

For sensors up to 650A: @ 50Hz and @60Hz: set at 375;

The screenshot shows the 'PM17xPRO\_USB - General Setup' dialog box. The 'Basic Configuration' section is highlighted with a green box. The 'Demand Setup' section is also visible below it.

Basic Configuration	
Wiring Mode	4LL3
PT Ratio	56.9
PT Secondary (L-L), V	386.6
V4 PT Ratio	1.0
V4 PT Secondary, V	230.0
CT Primary, A	375
I4 CT Primary, A	5
Nominal Frequency, Hz	50
Phase Order	ABC
L1 Current Direction	Regular
L2 Current Direction	Regular
L3 Current Direction	Regular
Demand Setup	
Power Block Demand Period, min	15
Number of Blocks in Sliding Demand	1
Power Demand Sync Source	Meter Clock
Volt Demand Period, s	900
Amp. Demand Period, s	900
Harm. Demand Period, s	900

Buttons at the bottom: Open, Save as..., Default, Print, Send, Receive, OK, Cancel, Apply, Help.

Figure 7-1: CT/PT Setup

Note: "PT Secondary (L-L),V" = "Primary Nominal Voltage (L-L)" / "PT RATIO".

For example above (Figure 7-1) for "Primary Nominal Voltage (L-L)" = 22kV.

## 7.2 Configuring Correction Parameters

Correction parameters for voltage sensors may be found on the sensor label (figure 7-2) as follows:

1. Amplitude correction: marked aU or al
2. Phase/Angle correction, marked pU or pl

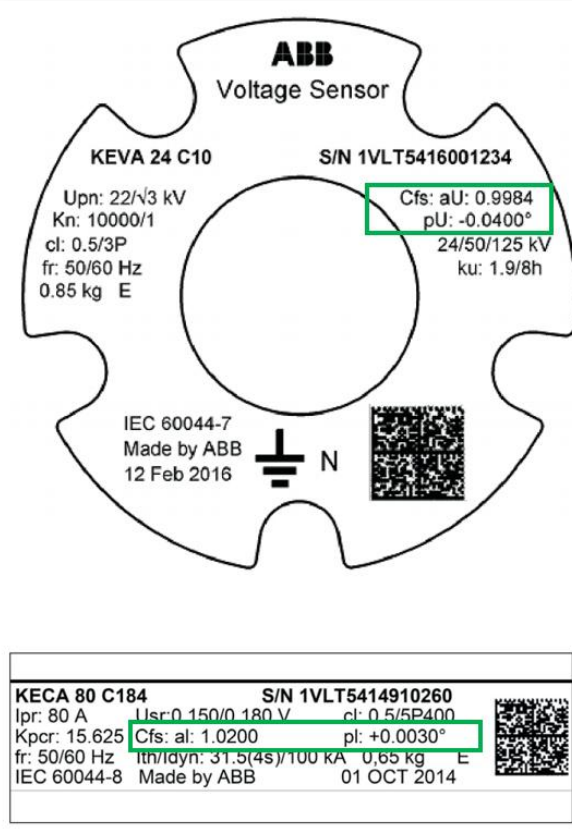

Figure 7-2: examples for correction parameters on sensor labels

To set these parameters, access the Transformer Correction tab, nested under General Setup (figure 7-3). Enter per correct phase as follows:

1. Amplitude correction (aU/al): enter the parameter displayed on the label in Transformer Correction/Ratio Correction Factor.
2. Angle correction (pU/pl): enter the parameter displayed on the label in Transformer Correction/Phase (Angle Error).

### NOTES!:

- angle correction is stated on sensor in degrees. Make sure to translate this to minutes (the parameter required by PAS) by multiplying the pU/pl parameter by 60.  
(for example, pU = -0.04°, pU/pl<sub>MIN</sub> = -0.04 x 60 = -2.4'(min) ~ -2)
- In case that Transformer Correction values are not default values: RATIO is differ than "1"; PHASE is differ than "0", insert the additional correction as follows:  
For example: RATIO<sub>OLD</sub> = 1.002, PHASE<sub>OLD</sub> = -3  
RATIO<sub>NEW</sub> = RATIO<sub>OLD</sub> x aU = 1.002 x 0.9984 = 1.0004 ~ 1.000  
PHASE<sub>NEW</sub> = PHASE<sub>OLD</sub> + pU = -3 + (-2) = -5'.

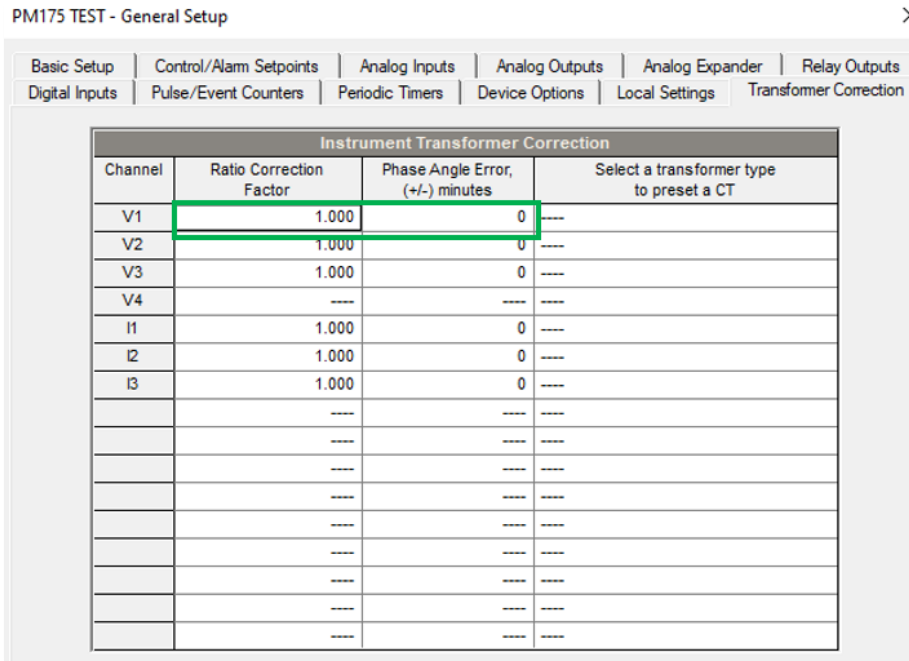

Figure 7-3: Entering Correction Parameters

### 7.3 Sensors tested and approved by ABB

Table 4: approved sensors

Sensors	Tested rating	Sensor Models
Voltage sensors		KEVA 17.5 B20, 17.5 B21 KEVA 24 B20, 24 B21 KEVA 24 Cxx (C10, C21, C22, C23, C24, C25, C26, C30 KEVA 24 Cxxc (C21c, C22c, C23c, C24c, C25c, C26c) KEVA 24 C2 4.1 KEVA 24 C2 4.1c “c” stands for Metal coated (conductive surface)
Combined sensors		KEVCY 24 RE1 KEVCY 36 RE1 KEVCD xx AE3 (12 AE3, 7.5 AE3, 24 AE3)

**Note:** The device is compatible with the listed ABB sensors complying with the IEC 60044-8:2002/ IEC 60044-7:1999 or IEC 61869-10:2017/ IEC 61869-11:2017 standards.

# Chapter 8 Display Operations

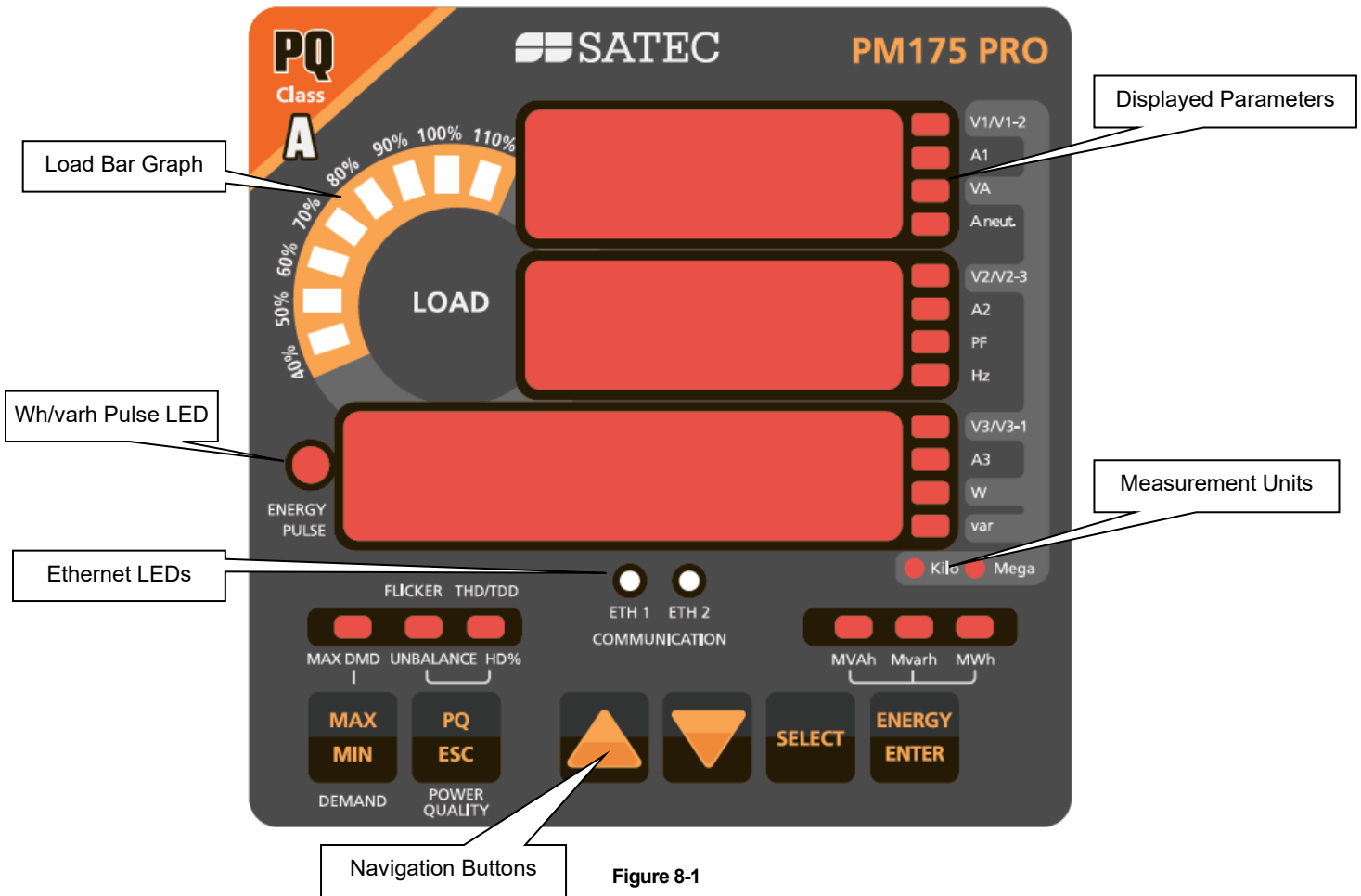

Figure 8-1

## 8.1 Indicators and Controls

### 8.1.1 Display Diagnostics



The display may indicate a connection error as shown on the left picture if it fails to establish a connection with the meter. Check the connection between the display module and the meter body. If the error message is still displayed, contact your local distributor.

### 8.1.2 Numeric LED Display

The meter has a simple user interface that allows you to view numerous measurement parameters by scrolling through different display pages. The numeric LED display shows up to three parameters at a time. Small rectangular or triangular LEDs at right and below the display indicate the displayed parameters and their measurement units.

The display layout may change depending on the meter type and mode of operation. There are three modes of display operation: data display, status display, and programming mode display.

### 8.1.3 Load Bar Graph

The load bar graph displays the amount, in percent (40% to 110%), of the present current load with respect to user-defined nominal load current. The reference nominal current can be set up in amps through the Display Setup menu. If it is set to 0 (default), the current load is referenced to the specified CT primary current.

### 8.1.4 Energy Pulse LED

The PM17X PRO has a red "Energy Pulse" LED. It flashes at a constant rate when a load is applied to the meter. There are two modes of LED operation: normal and test. In normal mode, the LED pulses indicate imported Wh at a rate of 1,000 pulses per kWh in secondary units. In test mode, the LED pulses indicate either imported Wh, or imported (inductive) varh at a rate of 10,000 pulses per kWh/kvarh. The energy test mode can be enabled through the Display Setup menu. When in test mode, the energy and demand accumulators do not account for consumed energy.

### 8.1.5 Ethernet LEDs

The meter has two yellow LEDs "Ethernet1" and "Ethernet2", which indicate activity on the two Ethernet communication ports.

The port's LED flashes when the port is receiving or transmitting data due to network activity.

When an Ethernet cable is connected to either "ETH1" or "ETH2", the corresponding LED might flash constantly, reflecting standard network traffic and negotiation processes typical of Ethernet communications. This occurs independently for each port, so "ETH1" LED activity is related to the "ETH1" port, and "ETH2" LED activity is related to the "ETH2" port.

### 8.1.6 Navigation Buttons

The PM17X PRO is provided with six push buttons that are normally used to navigate between different measurement displays. In programming mode, the buttons access the device setup menus and the default factory-set device settings can be changed.

## 8.2 Data Display

In data mode, the display is normally updated once per second; you can adjust the display update rate via the Display Setup menu.

### 8.2.1 Display Features

#### Measurement Units

Currents are always displayed in amperes with two decimal places.

Measurement units for voltage and power depend on the connection scheme of the meter:

- When direct wiring is used, voltages are displayed in volts with one decimal place, and power in kilowatts with three decimal places.
- When wiring via PT is used, for the PT ratio up to and including 4.0, voltages are displayed in volts, and power in whole kilowatts.
- For the PT ratio above 4.0, voltages are displayed in kilovolts, and power in megawatts with three decimal places.

The small round “Kilo” and “Mega” LEDs light up showing the appropriate measurement units for a displayed page.

#### Primary and Secondary Volts

Volts can be displayed in primary (default) or secondary units. The volts display mode can be changed through the Display Setup menu.

#### Phase Power Readings

In configurations with the neutral wire, in addition to total three-phase powers, the meter can show per-phase power readings. By default, they are disabled. See Display Setup on how to enable per-phase power readings in your meter.

#### Fundamental Component

The meter can display total power factor and active power for the fundamental component if it is enabled through the Display Setup menu. Whenever phase power readings are allowed, the PM17X PRO also displays per-phase power factor and active power for the fundamental component.

#### Auto Return

If no buttons are pressed for 30 seconds while the display Auto Return option is enabled, the display automatically returns to the main screen from any other measurement display or programming mode.

The Auto Return option can be enabled through the Display Setup menu

#### Auto Scroll

If no buttons are pressed for 30 seconds while in the common measurements display, and the Auto Scroll option is enabled in the meter, the display automatically scrolls through all available pages. The scroll interval can be adjusted through the Display Setup menu.

To stop auto scrolling, press briefly the UP or DOWN buttons.

## 8.2.2 Navigation Buttons



In Data Display mode, the navigation buttons function as follows.

The **MIN/MAX** button switches to the Min/Max - Maximum Demands display pages. When briefly pressed again, it switches back to the common measurements display.

The **PQ** button switches between different power quality/harmonic displays: Total Harmonics, Individual Voltage and Current Harmonics, and Power Quality parameters – short-term (Pst) and long-term (Plt) flicker, and voltage and current negative sequence unbalance. When briefly pressed once again, it switches back to the common measurements display

The **UP** and **DOWN** arrow buttons, labeled by arrowheads, scroll forwards and backwards through the display pages. Pressed briefly, they move one page forward or backward. If you hold down the button, the display pages are scrolled at rate of a twice per second.

Pressing both the UP and DOWN arrow buttons together returns to the first page within the current display.

The **SELECT** button operates once it's released. The button has two functions:

- When pressed briefly, it switches to programming mode.
- When pressed together with the ENTER button for more than 5 seconds, it resets Min/Max records, maximum demands, or energies depending on the currently displayed page. If the meter is password protected and a simple reset of data from the display is not allowed, the action has no effect.

The **ENERGY** button switches to the Energy display in the PM17X PRO. If TOU registers are configured in the meter, you can repeatedly press this button to scroll through all available TOU registers. When briefly pressed once again, it switches back to the common measurements display

## 8.2.3 Simple Reset of Accumulated Data

When the meter is not password protected, or the simple reset of data is allowed from the display regardless of the security setting (see "Display Setup"), the meter allows the simple "two-button" reset of the Min/Max registers, maximum demands, energies, and counters from the data display mode without entering the reset menu:

1. Select a display page where the data you want to reset is displayed:
  - Min/Max log - select a Min/Max page from the Min/Max Display.
  - Ampere and volt maximum demands - select the ampere or volt maximum demand page from the Min/Max Display.
  - Power maximum demands - select the power maximum demand page from the Min/Max Display.
  - Total and phase energies - select a total energy, or phase energy page from the Energy Display.
  - Counters – select a counter page from the Status Display
2. While holding the SELECT button, press and hold the ENTER button for about 5 seconds. The displayed data is reset to zero.

## 8.2.4 Common Measurements Display

Scroll through pages with the UP and DOWN arrow buttons.



Common Measurements (Main Display)		
1	V12 V23 <b>L</b> V31	Line-to-line volts
2	V1 V2 <b>P</b> V3	Line-to-neutral volts (in 4LN3, 3LN3, 3BLN3 configurations)
3	I1 I2 I3	Amps
4	kVA/MVA PF kW/MW	Total VA Total PF Total W
5	In Hz kvar/Mvar	Neutral current Frequency Total var
6	<b>U4</b>  V4	V4
7	<b>C4</b>  I4	I4
8	<b>Ph.L1</b> PF kW/MW	Phase L1 powers (if enabled)
9	kVA/MVA <b>Ph.L1</b> kvar/Mvar	Phase L1 powers (if enabled)
10	<b>Ph.L2</b> PF kW/MW	Phase L2 powers (if enabled)
11	kVA/MVA <b>Ph.L2</b> kvar/Mvar	Phase L2 powers (if enabled)
12	<b>Ph.L3</b> PF kW/MW	Phase L3 powers (if enabled)
13	kVA/MVA <b>Ph.L3</b> kvar/Mvar	Phase L3 powers (if enabled)

Common Measurements (Main Display)		
14	V1 V2 <b>1H</b> V3	Fundamental Voltages (if enabled)
15	I1 I2 <b>1H</b> I3	Fundamental Currents (if enabled)
16	<b>H01</b> PF kW/MW	Fundamental total powers (if enabled)
17	<b>H1.L1</b> PF kW/MW	Fundamental phase L1 powers (if enabled)
18	<b>H1.L2</b> PF kW/MW	Fundamental phase L2 powers (if enabled)
19	<b>H1.L3</b> PF kW/MW	Fundamental phase L3 powers (if enabled)

### 8.2.5 Min/Max and Max. Demands Display

Press the MIN/MAX button. The MIN/MAX LED, or MAX DEMAND LED in the PM17X PRO, is illuminated when in the MIN/MAX display. Use the UP and DOWN arrow buttons to scroll through the Min/Max and Max. Demand pages.

Note that volts readings are line-to-neutral in 4LN3, 3LN3 and 3BLN3 wiring modes, and line-to-line in other modes.



Min/Max and Maximum Demands		
1	V1/V12 V2/V23 <b>Lo</b> V3/V31	Minimum volts
2	I1 I2 <b>Lo</b> I3	Minimum amps
3	kVA/MVA PF <b>Lo</b> kW/MW	Minimum total VA Minimum total PF (absolute) Minimum total W
4	In Hz <b>Lo</b> kvar/Mvar	Minimum neutral current Minimum frequency Minimum total var
5	V1/V12 V2/V23 <b>Hi</b> V3/V31	Minimum volts

Min/Max and Maximum Demands		
6	I1 I2 <b>Hi</b> I3	Maximum amps
7	kVA/MVA PF <b>Hi</b> kW/MW	Maximum total VA Maximum total PF (absolute) Maximum total W
8	In Hz <b>Hi</b> kvar/Mvar	Maximum neutral current Maximum frequency Maximum total var
9	V1/V12 V2/V23 <b>Hd</b> V3/V31	Maximum volt demands
10	I1 I2 <b>Hd</b> I3	Maximum ampere demands
11	kVA/MVA PF <b>Hd</b> kW/MW	Maximum VA demand PF at maximum VA demand Maximum W demand
12	<b>Hd</b> kvar/Mvar	Maximum var import demand

### 8.2.6 Harmonics Display

Press the PQ/ESC button. The THD/TDD LED is illuminated. Press the button again to move to the individual harmonics, or to the flicker and unbalance displays. Use the UP and DOWN arrow buttons to scroll through harmonics and power quality measurements.

Note that voltage harmonics readings are line-to-neutral in the 4LN3, 3LN3, 3BLN3, 4LL3, 3LL3 and 3BLL3 wiring modes, and line-to-line in all other modes.

Total Harmonics		
1	V1/V12 THD V2/V23 THD <b>thd.</b> V3/V31 THD	Voltage THD
2	I1 THD I2 THD <b>thd.</b> I3 THD	Current THD
3	I1 TDD I2 TDD <b>tdd.</b> I3 TDD	Current TDD
4	I1 K-Factor I2 K-Factor <b>HF</b> I3 K-Factor	Current K-Factor



Individual Voltage Harmonics		
1	V1/V12 HD% V2/V23 HD% <b>02H</b> V3/V31 HD%	Order 2 harmonic distortion
2	V1/V12 HD% V2/V23 HD% <b>03H</b> V3/V31 HD%	Order 3 harmonic distortion
3	V1/V12 HD% V2/V23 HD% <b>63H</b> V3/V31 HD%	Order <b>63</b> harmonic distortion



Individual Current Harmonics		
1	I1 HD% <b>02H</b> I2 HD% I3 HD%	Order 2 harmonic distortion
2	I1 HD% <b>03H</b> I2 HD% I3 HD%	Order 3 harmonic distortion
3	I1 HD% <b>63H</b> I2 HD% I3 HD%	Order <b>63</b> harmonic distortion



Flicker/Unbalance		
1	V1 Pst <b>Pst</b> V2 Pst V3 Pst	Short term flicker
2	V1 Plt <b>Plt</b> V2 Plt V3 Plt	Long term flicker
3	<b>U.Unb</b>  V% unb	Voltage negative sequence unbalance, percent
4	<b>C.Unb</b>  I% unb	Current negative sequence unbalance, percent



## 8.2.7 Energy Display

Press the ENERGY button. The MVAh, Mvarh, or MWh LED is illuminated. If TOU registers are configured in the meter, press the button again to scroll through all active TOU registers.

Use the UP and DOWN arrow buttons to scroll through energy pages.

Along with total energies, per phase energy accumulators are displayed if phase energy calculation is enabled in the Device Options menu.



Total and Phase Energies		
1	<b>Ac.En.</b> <b>IP.</b> MWh	Total Wh import
2	<b>rE.En.</b> <b>IP.</b> Mvarh	Total varh import
3	<b>AP.En.</b>  MVAh	Total VAh
4	<b>Ac.En.</b> <b>EP.</b> MWh	Total Wh export
5	<b>rE.En.</b> <b>EP.</b> Mvarh	Total varh export
6	<b>Ac.En.</b> <b>IP.L1.</b> MWh	Phase L1 Wh import
7	<b>rE.En.</b> <b>IP.L1.</b> Mvarh	Phase L1 varh import
8	<b>AP.En.</b> <b>L1.</b> MVAh	Phase L1 VAh
9	<b>Ac.En.</b> <b>IP.L2.</b> MWh	Phase L2 Wh import
10	<b>rE.En.</b> <b>IP.L2.</b> Mvarh	Phase L2 varh import
11	<b>AP.En.</b> <b>L2.</b> MVAh	Phase L2 VAh
12	<b>Ac.En.</b> <b>IP.L3.</b> MWh	Phase L3 Wh import



Total and Phase Energies		
13	<b>rE.En.</b> <b>IP.L3.</b> Mvarh	Phase L3 varh import
14	<b>AP.En.</b> <b>L3.</b> MVAh	Phase L3 VAh

ENERGY  
ENTER



TOU Energy Register 1		
1	<b>rEG.1</b> <b>trF.1</b> MWh	Tariff 1 reading
2	<b>rEG.1</b> <b>trF.2</b> MWh	Tariff 1 reading
8	<b>rEG.1</b> <b>trF.8</b> MWh	Tariff 8 reading



ENERGY  
ENTER



TOU Energy Register 8		
1	<b>rEG.8</b> <b>trF.1</b> MWh	Tariff 1 reading
2	<b>rEG.8</b> <b>trF.2</b> MWh	Tariff 1 reading
8	<b>rEG.8</b> <b>trF.8</b> MWh	Tariff 8 reading



## 8.3 Status Display

The meter has separate status information pages accessible through the primary device menu. The Status Display shows rarely used information that is especially helpful when connecting the meter inputs and outputs to external equipment. For information on navigating in the menus, see “Using the Menu”.



To enter the Status Display:

1. From the Data Display, press the SELECT button to enter the primary device menu. The “StA” window is highlighted.
2. Press ENTER to enter the Status Display. Use the UP and DOWN arrow buttons to scroll through the status pages.



To exit the Status Display:

1. Press ESC to return to the primary device menu.
2. Press ESC to return to the Data display.



Status Display		
1	<b>PhS</b> <b>rot</b> POS/nEG/Err	Phase rotation order
2	V1 angle V2 angle <b>AG.</b> V3 angle	Voltage angles ( $\pm 180^\circ$ , referenced to V1)
3	I1 angle I2 angle <b>AG.</b> I3 angle	Current angles ( $\pm 180^\circ$ , referenced to V1)
4	<b>rEL</b> <b>1.2.</b> 00	Relay status
5	<b>St.In</b> <b>1.2.</b> 00	Status inputs
6		
7		
8		
9		
10		

## 8.4 Using the Menus

### 8.4.1 Navigation Buttons



The PM17X PRO has a menu-driven setup. To enter the menus, press and release the SELECT button.

The **SELECT** button selects (highlights) an active window in which you can select or change a desired menu item. The button operates once it's briefly pressed and released.

The **UP** and **DOWN** arrow buttons scroll through menu items in the highlighted window forwards and backwards, and allow changing a highlighted item when entering numbers.

The **ENTER** button confirms the selection of a menu item or a number in the highlighted window, thus allowing to enter a submenu or to store a changed item.

The **ESC** button is "Escape" leaving the highlighted item unchanged or returning to the upper-level menu.

### 8.4.2 Selecting Menus

To access the meter menus, press and release the SELECT button. The primary meter menu is open as shown below. The menu has three entries:

- **StA - Status Display entry (see "Status Display" above)**
- **OPS – Main setup menu entry allowing to review setup options**
- **CHG – Main setup menu entry allowing to change setups**

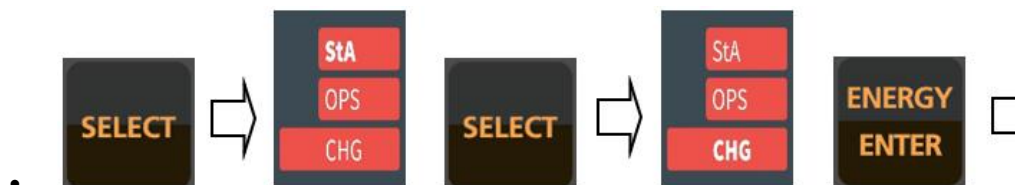

To enter the Status Display:

1. If the StA window is not highlighted, use the SELECT button to activate it.
2. Press the ENTER button to enter the Status Display

To review the meter setup options:

1. Press the SELECT button to activate the OPS window.
2. Press the ENTER button to enter the main menu.

To change the meter setup, or to clear the accumulated values:

1. Press the SELECT button to activate the CHG window.
2. Press the ENTER button to enter the main menu.

### 8.4.3 Entering the Password

The Setup Change menu can be secured by a four-digit user password. The meter is primarily shipped with the password preset to 0 and password protection disabled. You can change the password and enable password protection through the Access Control menu (see [Meter Security](#)).

If authorization is not required, just press the ENTER button to move to the Main menu; otherwise, you should enter a correct password to be authorized to access the meter setup.



To enter the password:

1. Adjust the first digit with the UP and DOWN arrow buttons.
2. Press the SELECT button to advance to the next digit.
3. Adjust the remaining password digits in the same manner.
4. Press ENTER to confirm the password.

If the password entered is correct, you move to the Main menu, otherwise you return to the previous menu.

Selecting the OPS or CHG entry moves you to the Main menu that is represented by two entries:

The upper window displays a secondary menu list, while the bottom item is an assisting exit window.

### 8.4.4 Selecting a Menu Entry

To select a menu entry from the menu list:



1. Highlight the upper item by pressing the SELECT button.
2. Scroll through the menu list by pressing briefly the UP and DOWN arrow buttons until the desired menu entry appears.
3. Press the ENTER button.

### 8.4.5 Viewing and Changing Setup Items

A second level menu normally consists of three items: the upper static window indicates the menu name, while the middle window represents a list of setup parameters you can scroll through, and the lower item shows the present parameter value.



To select a parameter, you want to view or change:

1. Highlight the middle window by pressing the SELECT button.
2. Scroll through the parameter list with the UP and DOWN buttons until the desired parameter name appears.

To change the selected parameter:



1. Press the SELECT button to highlight the lower item.
2. If a number represents the parameter, adjust it to the desired value with the UP and DOWN arrow buttons. When briefly pressed, the button increments or decrements the number by one. When the button is pressed continuously, the number is changed approximately twice per second.
3. If a name represents the parameter, select the desired option with the UP and DOWN arrow buttons.
4. To store your new selection, press the ENTER button.
5. To leave the parameter unchanged, press the ESC button.

You will return to the parameter list to select another parameter or return to the main menu.

To exit the menu, press ESC.

## 8.5 Menu Operations

### 8.5.1 Basic Device Settings

This menu allows you to configure the basic meter settings that define the general operating characteristics of the device. To enter the menu, select the “baSc” entry from the main menu, and then press the ENTER button.

To select a setup option:

1. Press the SELECT button to activate the middle window.
2. Use the UP and DOWN arrow buttons to scroll to the desired option.

To change the option:

1. Press the SELECT button to activate the lower window.
2. Use the UP and DOWN arrow buttons to select the desired option.
3. Press ENTER to confirm your changes and to store your new setting, or press ESC to discard changes.

To exit the menu, press ESC.



Table 5

Label	Parameter	Options	Default	Description
ConF	Wiring connection (configuration) mode	See “ <a href="#">Basic Meter Setup</a> ” in Chapter 10.	4Ln3	The wiring connection of the device
Pt	PT ratio	1.0-6500.0	1.0	The phase potential transformer’s primary to secondary ratio
U.SEC	Nominal secondary voltage	10-690V	120V	Nominal secondary line-to-line voltage
Ct	CT primary current	1-30,000 A	5 A	The primary rating of the phase current transformer
Pt4	PT4 ratio	1.0-6500.0	1.0	The phase potential transformer’s primary to secondary ratio
Ct4	CT4 primary current	1-30,000 A	5 A	The primary rating of the phase current transformer
d.P	Power block demand period	1, 2, 3, 5, 10, 15, 20, 30, 60 min, E=external sync	30 min	The length of the demand period for power demand calculations. If the external synchronization is selected, a pulse front on the digital input DI1 denotes the start of the demand interval.
nd.P	The number of blocks in the sliding window	1-15	1	The number of blocks to be averaged for sliding window demands
Ad.P	Ampere, volt and THD demand period	0-1800 sec	900 sec	The length of the demand period for ampere, volt and THD demand calculations
Freq	Nominal frequency	50,60 Hz	60 Hz	The nominal line frequency
LoAd	Maximum Demand load current	0-20,000 A	0	The maximum demand load current (0 = CT primary)

△ Always specify the wiring mode and transformer ratings prior to setting up setpoints and analog outputs.

△ The maximum value for the product of the phase CT primary current and PT ratio is 57,500,000. If the product is greater, power readings are zeroed.

## 8.5.2 Device Options



This menu allows you to change the user-configurable device options or put the meter into energy test mode. To enter the menu, select the “OPtS” entry from the Main menu, and then press the ENTER button.

To select a setup option:

1. Press the SELECT button to activate the middle window.
2. Use the UP and DOWN arrow buttons to scroll to the desired option.

To change the option:

1. Press the SELECT button to activate the lower window.
2. Use the UP and DOWN arrow buttons to select the desired option.
3. Press ENTER to confirm your changes and to store your new setting, or press ESC to discard changes.

To exit the menu, press ESC.

The following table lists available options

**Table 6**

Label	Parameter	Options	Default	Description
P.cAL	Power calculation mode	rEAc (reactive power), nAct (non-active power)	Reactive	The method used for calculating reactive and apparent powers
roLL	Energy roll value <sup>E</sup>	10.E4=10,000 10.E5=100,000 10.E6=1,000,000 10.E7=10,000,000 10.E8=100,000,000 10.E9=1,000,000,000	10.E9	The value at which energy counters roll over to zero
tESt	Energy test mode	OFF = disabled Ac.Ei = Wh pulses rE.Ei = varh pulses	Disabled	Setting this option puts the meter into the energy test mode

### 8.5.3 Communication Ports



These two menus allow you to configure parameters for communication ports COM1 and COM2. To enter the menu, select “Prt.1” for COM1 or “Prt.2” for COM2 from the main menu, and then press the ENTER button.

To select a setup option:

1. Press the SELECT button to activate the middle window.
2. Use the UP and DOWN arrow buttons to scroll to the desired option.

To change the option:

1. Press the SELECT button to activate the lower window.
2. Use the UP and DOWN arrow buttons to select the desired option.
3. Press ENTER to confirm your changes and to store your new setting, or press ESC to discard changes.

To exit the menu, press ESC.

The following tables list available port options.

COM1 Settings

**Table 7**

Label	Parameter	Options	Default	Description
Prot	Communications protocol	rtu = Modbus RTU ASCII=Modbus ASCII dnP3 = DNP3 <sup>1</sup>	Modbus RTU	The communications protocol supported by the port
Addr	Device address	Modbus: 1-247 DNP3: 0–65532	1	Device network address
bAud	Baud rate	300-115200 bps	19200 bps	The port baud rate
dAtA	Data format and parity	7E, 8N, 8E	8N	7E data format should not be used with the Modbus RTU and DNP3 protocols

<sup>1</sup>Selecting the DNP3 protocol on the Ethernet port launches the DNP3/TCP server along with the Modbus/TCP server allowing simultaneous connections on both TCP ports. Selecting the Modbus protocol for the port disables the DNP3/TCP server.

The meter automatically detects a replaceable communication module and does not allow you to change the interface, baud rate or data format for the Ethernet port.

## 8.5.4 Network Address

This menu allows you to configure the device IP address and the default gateway address for the Ethernet port. To enter the menu, select "nEt" from the main menu, and then press the ENTER button.

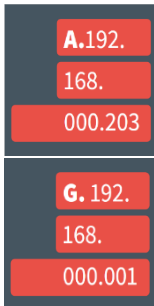

To change the IP Address and Default Gateway:

1. To change the device IP address, select the "A" entry in the upper window with the UP and DOWN arrow buttons. To change the default gateway address, select the "G" entry.
2. Press the SELECT button to activate the first address digit.
3. Use the UP and DOWN arrow buttons to adjust the digit.
4. Press the SELECT button to advance to the next digit.
5. Adjust the remaining address digits.
6. Press ENTER to confirm your new setting, or press ESC to discard changes.

To exit the menu, press ESC.

### Ethernet 1 Settings

Label	Parameter	Options	Default	Description
A	IP address	IP Address	192.168.0.203	The Device IP address
G	Default Gateway	IP Address	192.168.0.203	The Gateway IP address
dHcp	DHCP	diS = disabled En = enabled	Disabled	Enable DHCP

Additional for nEt.2 – Daisy Chain Mode:

1. When in the "nEt.2" menu, you will also have the option to configure Daisy Chain mode (select "DC"). Use the UP and DOWN arrow buttons to toggle between enabling and disabling Daisy Chain mode. Enabling Daisy Chain mode allows the second Ethernet port ("nEt.2") to connect with multiple devices in a series, impacting how it interacts with the network.
2. After adjusting the settings, press ENTER to confirm your new configuration, or press ESC to discard changes.

To exit the menu, press ESC.

### Ethernet 2 Settings

Label	Parameter	Options	Default	Description
A	IP address	IP Address	192.168.0.203	The Device IP address
G	Default Gateway	IP Address	192.168.0.203	The Gateway IP address
dHcp	DHCP	diS = disabled En = enabled	Disabled	Enable DHCP
DC	Daisy Chain	diS = disabled En = enabled	Disabled	Enable Daisy chain mode

### 8.5.5 Display Setup



This menu allows you to configure options for the meter display, and view display and device firmware versions. To enter the menu, select the “diSP” entry from the main menu and press the ENTER button.

To select a setup option:

1. Press the SELECT button to activate the middle window.
2. Use the UP and DOWN arrow buttons to scroll to the desired option.

To change the option:

1. Press the SELECT button to activate the lower window.
2. Use the UP and DOWN arrow buttons to select the desired option.
3. Press ENTER to confirm the changes and to save your new setting, or press ESC to discard changes.

To exit the menu, press ESC.

The following table lists available options.

**Table 8**

Label	Parameter	Options	Default	Description
UPdt	Display update rate	0.1-10.0 sec	1 sec	Defines the interval between display updates
ScrL	Auto scroll interval	None, 2-15 sec	None	Defines the scroll interval for the main data display or disables auto scroll
rEtn	Auto return to the main screen	diS = disabled, En = Enabled	Enabled	Enables automatic return to the main display if no buttons are pressed for 30 seconds
bAr	Reference load current for LED bar graph	0-20,000A (0 = CT primary current)	0	Defines the nominal load (100%) level for the bar graph display
Uolt	Primary/Secondary volts units	Pri, SEc	Primary	Selects primary or secondary units for volts display
Ph.P	Phase powers display mode	diS, En	Disabled	Disables or enables phase powers in the main display
Fund.	Fundamental component display mode	diS, En	Disabled	Disables or enables fundamental values in the main display
dAtE	Date order	dnY, ndY, Ynd (d=day, n=month, y=year)	mm.dd.yy	Defines the date order in the RTC display
rSt	Simple reset mode	PASS = password required En = enabled	PASS	PASS = the simple reset is not allowed when password protection is enabled En = enables the simple reset buttons regardless of password protection
SoFt.	Display firmware version	N/A	N/A	Shows display firmware version, like 1.2.8
SoFt.	Device firmware version	N/A	N/A	Shows device firmware version, like 15.01.09

### 8.5.6 Meter Security



The Access Control menu allows you to change the user password and enable or disable password protection. To enter the menu, select the “AccS” entry from the main menu and press the ENTER button.

The password in your meter is preset to 0 at the factory, and password protection is disabled.

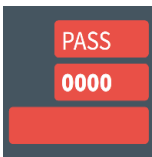

To change the password:

1. Select the “PASS” entry in the upper window with the UP and DOWN arrow buttons.
2. Press the SELECT button to activate the first password digit.
3. Use the UP and DOWN arrow buttons to adjust the digit.
4. Press the SELECT button to advance to the next digit.
5. Adjust the remaining password digits.
6. Press ENTER to confirm your new password.

△ Your new password is effective for both the display and communication ports.

### 8.5.7 Setting the Device Clock

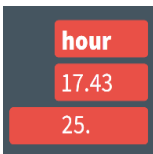

To enter the menu, select the “rtc” entry from the main menu and press the ENTER button. This menu allows you to set up the device clock and to configure your local time zone settings.

To select a setup option, use the UP and DOWN arrow buttons from the upper window.

To change the time, date, or daylight savings setting:

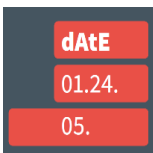

1. Highlight an item you want to change by pressing briefly the SELECT button. When you enter the time setup display, the hours and minutes are frozen to allow you to adjust them.
2. Adjust the selected item with the UP and DOWN arrow buttons.
3. Highlight the next item you want to change and adjust it in the same manner.
4. Press ENTER to confirm your changes, or press ESC to leave the clock settings unchanged. If you confirm the time change while the seconds are highlighted, the seconds are zeroed; otherwise they stay unchanged.

To exit the menu, press ESC.

The following table lists available options.

**Table 9**

Label	Option	Format/Range	Description
hour	Time	hh.mm.ss	The time is displayed as hh.mm.ss, where the hours and minutes are shown in the middle window separated by a dot, and the seconds - in the lower window.
dAtE	Date	YY.MM.DD, MM.DD.YY, DD.MM.YY	The date is displayed as per the user definition, where the first two items are shown in the middle window, and the last one - in the lower window. For instructions on how to select the date format, see “Display Setup”.

Label	Option	Format/Range	Description
dAY	Day of week	Sun = Sunday Mon = Monday TuE = Tuesday UEd = Wednesday thu = Thursday Fri = Friday Sat = Saturday	The day of the week is displayed in the lower window. It is set automatically when you change the date.
dSt	Daylight savings time option	diS = disabled En = enabled	When DST is disabled, the RTC operates in standard time only. When enabled, the device automatically updates the time at 2:00 AM at the pre-defined DST switch dates.
dSt.S	DST start date	Month-week-weekday Week = 1 <sup>st</sup> , 2 <sup>nd</sup> , 3 <sup>rd</sup> , 4 <sup>th</sup> or LSt (last week of the month)	The date when Daylight Savings Time begins. The DST switch point is specified by the month, week of the month and weekday. By default, DST starts at 2:00 AM on the first Sunday in April of each year.
dSt.E	DST end date	Month-week-weekday Week = 1 <sup>st</sup> , 2 <sup>nd</sup> , 3 <sup>rd</sup> , 4 <sup>th</sup> or LSt (last week of the month)	The date when Daylight Savings Time ends. The DST switch point is specified by the month, week of the month and weekday. By default, DST ends at 2:00 AM on the last Sunday in October of each year.

### 8.5.8 Resetting Accumulators and Maximum Demands



To enter the menu, select the “rst” entry from the main menu, and then press the ENTER button.

The Reset menu allows you to separately reset minimum/maximum log records, maximum demands and counters.

To reset the desired registers:

1. Highlight the middle window by pressing briefly the SELECT button.
2. Select the desired entry by scrolling through the list with the UP and DOWN arrow buttons until the desired entry appears.
3. Press the SELECT button briefly to highlight the lower item.
4. Press and hold the ENTER button for 5 seconds.
5. Release the button. The “do” entry is replaced with “done” showing the operation is complete.

The following table shows available options.

**Table 10**

Label	Description
Lo.Hi	Clears Min/Max log
A.dnd	Clears maximum ampere, volt and harmonic demands
P.dnd	Clears maximum power demands
dnd	Clears all maximum demands
Enr	Clears all total energies
tOU.d	Clears summary and TOU maximum demands
tOU.E	Clears summary and TOU energy registers
Cnt	Clears all counters
Cnt1 – Cnt4	Clears counter #1-#4

## Chapter 9 Using PAS Software

The support PAS software is a configuration and data acquisition tool that allows you to configure all of the PM17X PRO features, monitor your meters on-line, retrieve recorded files and view reports. PAS can communicate with your PM17X PRO via a serial port and via the Ethernet.

This chapter gives information on how to install and run PAS on your computer, and how to prepare information for your meter using PAS.

See Chapter 10 [Configuring the PM17X PRO](#) for instructions on how to configure particular features in your meter. Refer to Chapter 15 and Chapter 12 Chapter 16 for instructions on retrieving data from the meters and viewing reports.

### 9.1 Installing PAS

You need PAS V1.55 or higher to take an advantage of the meter data logging options.

To install PAS on your PC:

1. Download the latest PAS software from Satec website:
2. <https://www.satec-global.com/power-analysis-software>
3. Open My Computer on your Desktop.
4. Select the PAS directory, and then double click on Setup (shown as an Application type file).
5. Follow InstallShield® Wizard instructions on the screen.

PAS is installed by default to the C:\Pas folder.

When installation is complete, the PAS icon appears on your Desktop. Double click on the PAS icon to run PAS.

For general information on how to work with PAS, see the "PAS Getting Started".

## 9.2 Creating a New Site for your Meter

PAS keeps all communication and configuration data for your meter in a configuration database called a site database. During configuration, store all setup data to the site database so that PAS recognizes device properties regardless of whether the meter is online or offline.

To communicate with the meters, create a separate site database for each device.

To create a new database for your meter:

1. Select Configuration from the Tools menu.

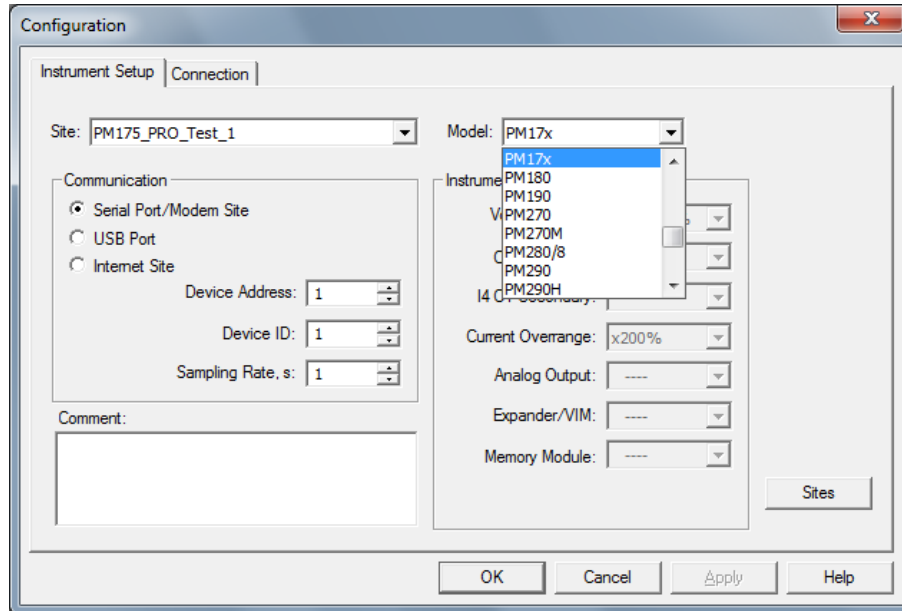

**Figure 9-1 Configuration Dialog Box – Instrument Setup Tab**

2. Click the Sites button on the right-hand-side.

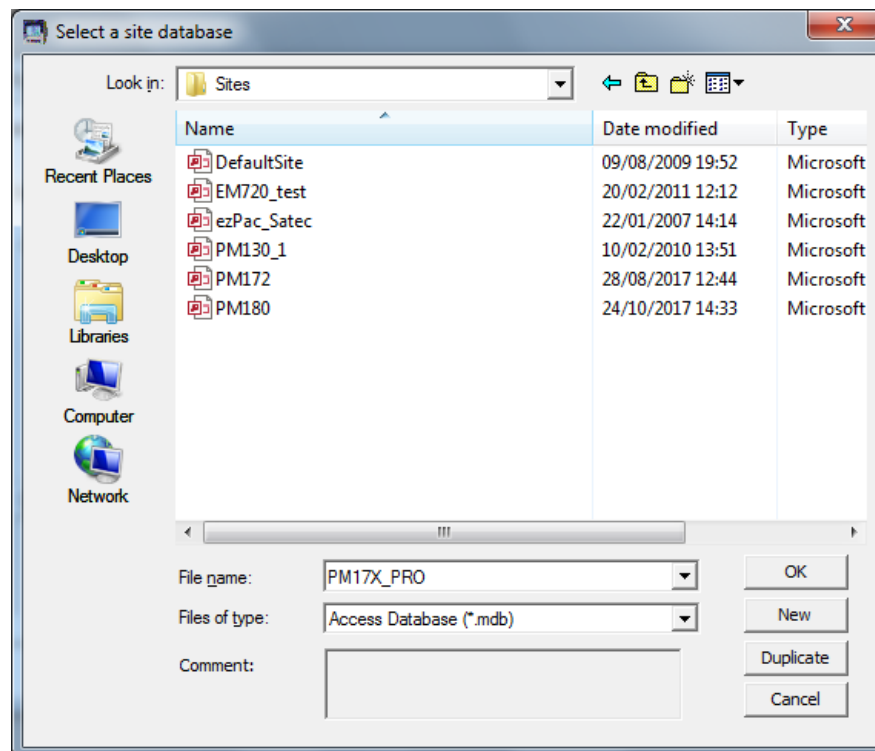

**Figure 9-2**

3. From the Look in box, select the directory where a new database will be stored. By default, it is the Sites directory.
4. Type a site name for your device in the File name box, click New, and then click OK.
5. On the Instrument Setup tab, select PM17X PRO in the Model box. PAS automatically selects the appropriate instrument options for your meter.
6. If you wish to add any comments for your meter, type the comments in the Comment box.

## 9.3 Setting up Communications

You can communicate with the PM17X PRO via a PC RS-485 serial port or through the Internet.

To configure communications with the PM17X PRO:

1. Select Configuration from the Tools menu. Under the Communication group on the Instrument Setup tab, select the type of connection for your device.
2. Set the device communication address you assigned to the PM17X PRO Port. When communicating via the Ethernet, the PM17X PRO responds to any address you select.
3. In the Sampling Rate box, select a rate at which PAS updates data on your screen when you continuously poll the device in the PAS Data Monitor.

The communication protocol and port settings must match the settings you made in your meter.

### 9.3.1 Communicating through a Serial Port

Select Serial Port on the Configuration tab, and then click on the Connection tab to configure your serial port settings.



Figure 9-3 Serial Port Setup Dialog Box

#### Configuring a Serial Port

1. On the Connection tab, select a COM port from the Device box, and then click Configure.
2. Specify the baud rate and data format for the port. Choose the same baud rate and data format as you have set in the meter, and then click OK.

The factory settings for the local PM17X PRO RS-485 ports are 9600 baud, 8 bits with no parity.

## Selecting the Communications Protocol

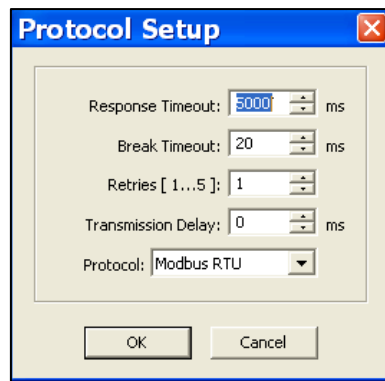

**Figure 9-4 Protocol Setup Dialog Box**

1. On the Connection tab, click Protocol.
2. In the Protocol box, select the same communications protocol as you have set in your meter.
3. In the Response Timeout box, define the maximum time that PAS should wait for the meter response before announcing a failure.
4. In the Break Timeout box, define the maximum line idle time that PAS should wait after receiving the last message character before closing a connection with the Modbus RTU or DNP3 protocol. It does not affect ASCII communications. Note that this time is added to the message transfer time, and excessive increasing it may slow down communications. If you frequently receive the "Communication error" message, try to increase Break Timeout.
5. In the Retries box, define the number of attempts that PAS should use to receive a response from the meter in the event the communication fails, before announcing a communication failure.

### 9.3.2 Communicating through the Internet

If you are communicating through the Ethernet port, define the IP address of your meter on the network.

To configure the meter IP address:

1. On the Instrument Setup tab, select Internet Site.
2. Click on the Connection tab.
3. Click on the IP address and type in the IP address of your meter. The default IP address preset in the meter at the factory is 192.168.0.203.
4. In the Protocol box, select the communications protocol for the TCP port. The meter provides Modbus/TCP connections on TCP port 502 and DNP3/TCP connections on port 20000. The host port is set automatically as you select the protocol. Select Modbus RTU/TCP for Modbus/TCP or DNP3 for DNP3/TCP.
5. In the Wait for answer box, adjust the time that PAS waits for a connection before announcing an error.

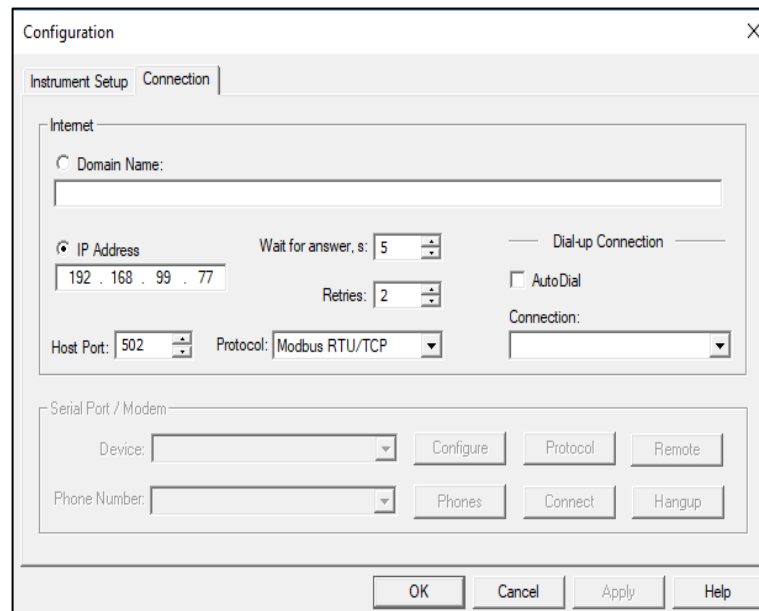

**Figure 9-5 Configuration Dialog Box – Connection Tab**

6. In the Retries box, specify the number of retries PAS will use to receive a response from the meter if communications fail.
7. Click OK.

## 9.4 Setting Up the Meter

### 9.4.1 Preparing Setups for the Meter

PAS allows you to prepare setup data for your meter off-line without the need to have it connected to your PC.

To prepare a setup for your meter:

1. Select the device site from the list box on the PAS toolbar.
2. Select the desired setup group from the Meter Setup menu. Click on the tab with the setup you want to create or modify.
3. Fill in the boxes with the desired configuration data for your meter.
4. Click the Save as... button to store the data to the meter site database.
5. Click OK.



Always set up and store the Basic Setup data to the site database first. PAS uses this data as a reference when arranging other meter setups.

To save your setup to another site database:

1. Click the Save as... button.
2. Select the target database from the file pane.
3. Click OK.

You can also reuse a setup from another site by copying it to your present site database.

To copy a setup from another site's database:

1. Click Open.
2. Select the desired source site database.
3. Click OK. The opened setup is copied to your dialog window.
4. Click the Save as... button.
5. Select the target database from the file pane.
6. Click OK.

To copy all setups from one site database to another site's database:

1. In the list box on the toolbar, select a source device site from which you wish to copy setups.
2. Select Copy to... from the Meter Setup menu.
3. Select the target site database to which you wish to copy setups, and click OK.

## 9.4.2 Downloading Setups to the Meter

You can update each setup in your meter one at a time or download all setups together from the site database.

### Individual Download

To update a particular setup in your meter:

1. Check the On-line button on the PAS toolbar
2. Select a meter site from the list box on the toolbar.
3. Select the desired setup group from the Meter Setup menu. Click on the setup tab you want to download to the meter. As the setup dialog box opens, PAS retrieves and displays the present meter setup data.
4. If you wish to download a setup saved in the site database, click Open, and then click OK, or fill in the boxes with the desired configuration data for your device.
5. Click Send.

### Batch Downloads

To download all setups to your device at once:

1. Check the On-line button on the PAS toolbar
2. Select the device site from the list box on the toolbar.
3. Select Download Setups from the Meter Setup menu.

## 9.4.3 Uploading Setups from the Meter

### Individual Upload

To get a particular setup from your device:

1. Check the On-line button on the PAS toolbar.
2. Select a meter site from the list box on the toolbar, and then select the desired setup group from the Meter Setup menu.
3. Click on the tab of the setup you want to read from the meter. As the dialog box opens, PAS retrieves and displays the present setup data from the meter. Click Receive if you wish to retrieve the meter setup once again.
4. To store the setup to the meter site database, click Save As, and then click OK.

### Batch Upload

To upload all setups from the device to the site database at once:

1. Check the On-line button on the toolbar.
2. Select the device site from the list box on the toolbar.
3. Select Upload Setups from the Meter Setup menu.

## 9.5 Authorization

If communications with your meter is secured, you are prompted for the password when you send new setup data to the meter.

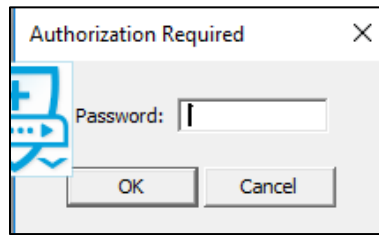

**Figure 9-6 Authorization Dialog Box**

Enter the password and click OK.

If your authorization was successful, you are not prompted for the password again until you close the dialog box.

See [Meter Security](#) in Chapter 8 for more information on the meter password security.

## 9.6 Upgrading Device Firmware

Your meter has upgradeable firmware. If you need to upgrade your device, download a new firmware file to the meter through PAS.

Firmware can be downloaded via the Modbus RTU or Modbus/TCP protocol through any communication port.

To download a new firmware file to your device:

1. Ensure that the communication port you are connected through to the meter operates in Modbus mode.
2. If you are connected to the meter through a serial interface, it is recommended to set the port baud rate to 115,200 bps. See [Setting Up Serial Communication Ports](#) on how to remotely change the protocol and baud rate in your meter.
3. Ensure that the On-line button on the PAS toolbar is checked, and then select Flash Downloader from the Monitor menu and confirm downloading.
4. Point to the firmware upgrade file for your meter, click Open, and then confirm upgrading the meter.

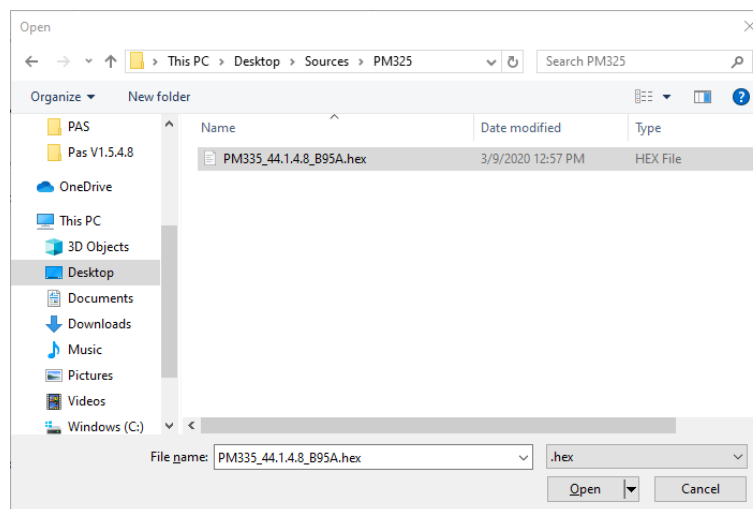

**Figure 9-7 selecting the firmware file for upgrading**

5. You are asked for the password regardless of the password protection setting in your meter. Type the meter password, and click OK. If you did not change the password in the meter, enter the default password 0.

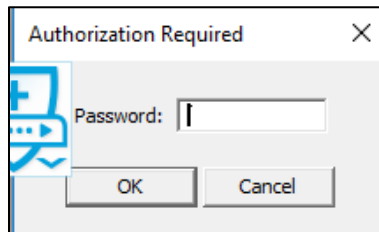

Figure 9-8

6. Wait until PAS completes upgrading your device. It takes about 3-4 minutes at 115,200 bps to download the file to the meter.

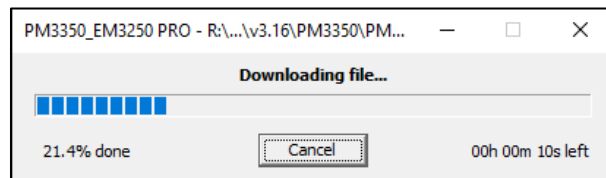

Figure 9-9

7. After upgrading firmware is completed, the meter restarts, so communications can be temporarily lost. You may need to wait a short duration until PAS restores a connection with your device.

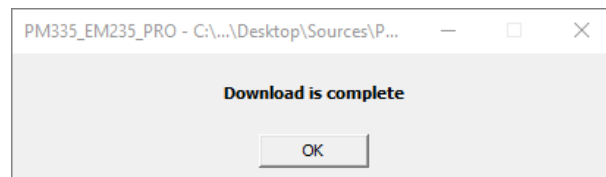

Figure 9-10

## Chapter 10 Configuring the PM17X PRO

This chapter describes how to configure different options in your meter from the front panel display and via PAS.

### 10.1 Configuring Communications

#### 10.1.1 Setting Up Serial Communication Ports

##### Using PAS

Select Communications Setup from the Meter Setup menu, and then click on the Serial Ports Setup tab. In the Port box, select the desired device port.

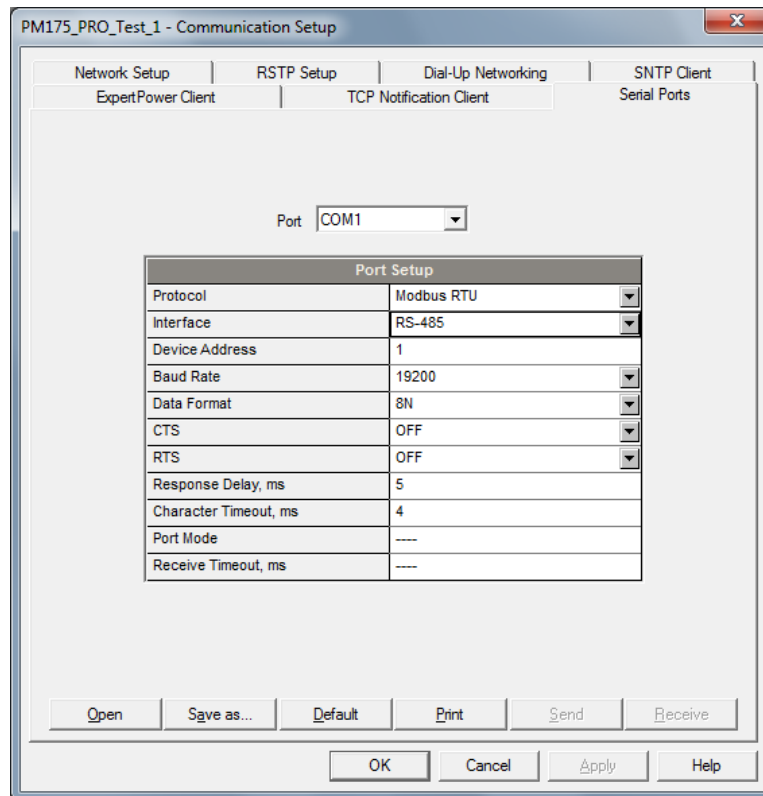

**Figure 10-1 Communication Setup Dialog Box – Serial Ports Setup Tab**

See Table 11 below for available communication options.

**Table 11: COM Port Options**

Parameter	Options	Default	Description
Protocol	MODBUS RTU DNP3 IEC 62056-21 IEC 60870-5	MODBUS RTU	The communications protocol for the port
Interface	COM	RS-485	Communication interface.
Device address	MODBUS: 1-247 DNP3: 0-65532	1	Device network address
Baud rate	300 bps-115.2 kbps	19200 bps	The port baud rate

Parameter	Options	Default	Description
Data format	7E, 8N, 8E	8N	Data format and parity. 7E data format should not be used with the MODBUS RTU and DNP3 protocols
Response delay	0-1000 ms	5 ms	The minimum time after the last request character is received to start the transmission.
Character Timeout	0-1000 ms	4 ms	The maximum time between character reception

## 10.1.2 Setting Up Ethernet

### Using PAS

Select Communications Setup from the Meter Setup menu, click on the Network Setup tab and then select Network 1 or 2.

The screenshot shows the 'PM175\_PRO\_Test\_1 - Communication Setup' dialog box with the 'Network Setup' tab selected. The 'Network' dropdown is set to '1'. The 'Current Network Settings' table is as follows:

Current Network Settings	
IP Address	0 . 0 . 0 . 0
Subnet Mask	0 . 0 . 0 . 0
Default Gateway	0 . 0 . 0 . 0
MAC Address	000000000000

The 'Network Setup' table is as follows:

Network Setup	
Device IP Address	192 . 168 . 0 . 203
Network Subnet Mask	255 . 255 . 255 . 0
Network Default Gateway	192 . 168 . 0 . 1
Use DHCP	NO
Secondary TCP Port	----
Primary DNS IP Address	0 . 0 . 0 . 0
Secondary DNS IP Address	0 . 0 . 0 . 0
Connection Idle Timeout, s	120
TCP Keepalive Time, s	----
Device Address	----
Switch Mode	Separated

Buttons at the bottom include: Open, Save as..., Default, Print, Send, Receive, OK, Cancel, Apply, and Help.

Figure 10-2

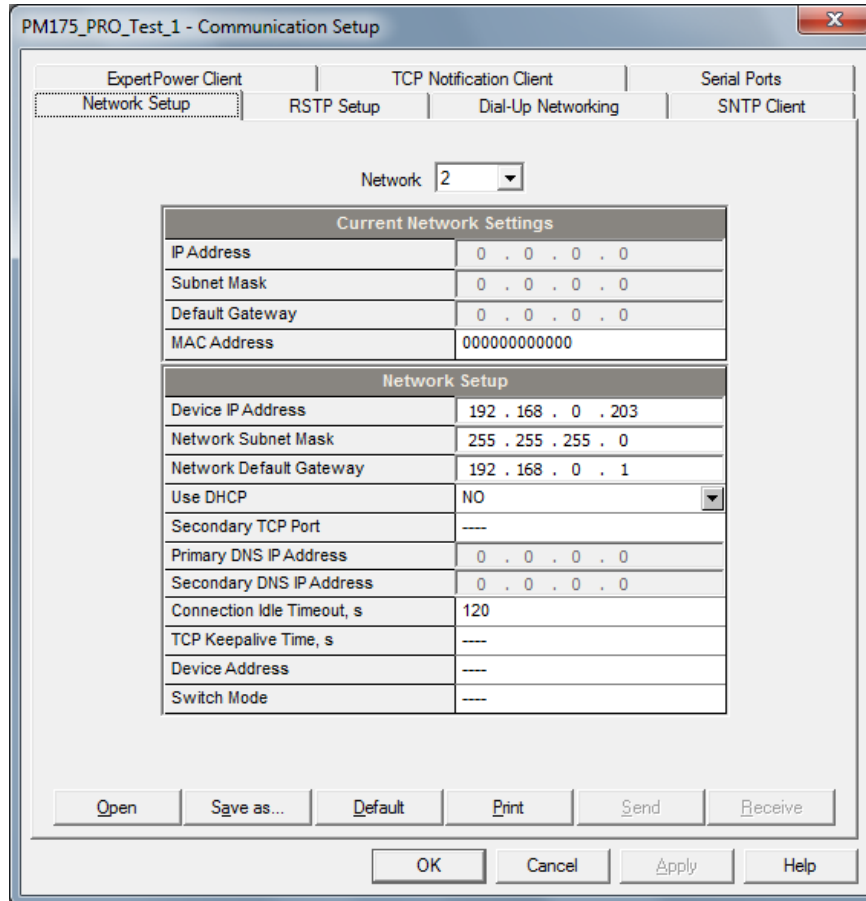

Figure 10-3 Communication Setup Dialog Box – Network 1/2 Setup Tab

The table below lists available network options.

**Table 12: Ethernet Setup Options**

Parameter	Options	Default
Device IP Address		192.168.0.203
Network Subnet Mask		255.255.255.0
Network Default Gateway		192.168.0.1
Use DHCP	YES/NO	NO
Switch Mode (applicable in Network 1 setup menu only)	Daisy chain/Separated	Separated

**NOTES:**

1. The meter provides the permanent MODBUS TCP server on port 502.
2. Selecting the DNP3 TCP service port launches the second DNP3 TCP server allowing simultaneous connections on both TCP ports. Selecting the MODBUS TCP port disables the DNP3 TCP server.
3. When you change the device network settings through the Ethernet port, the device port restarts so communication will be temporarily lost. You may need to wait some additional time until PAS restores a connection with your device.

### 10.1.3 Setting Up RSTP in Daisy Chain mode

Daisy chain may be implemented with fallback connection where a circular closed chain is connected. To enable such connection, RSTP support must be enabled within the device. This configuration is available only from the PAS.

#### Using PAS

Select Communications Setup from the Meter Setup menu, click on the RSTP Setup. Enable the capability by selecting YES for the RSTP Enabled field. Apply changes to all other default configuration values as required by the network administrator.

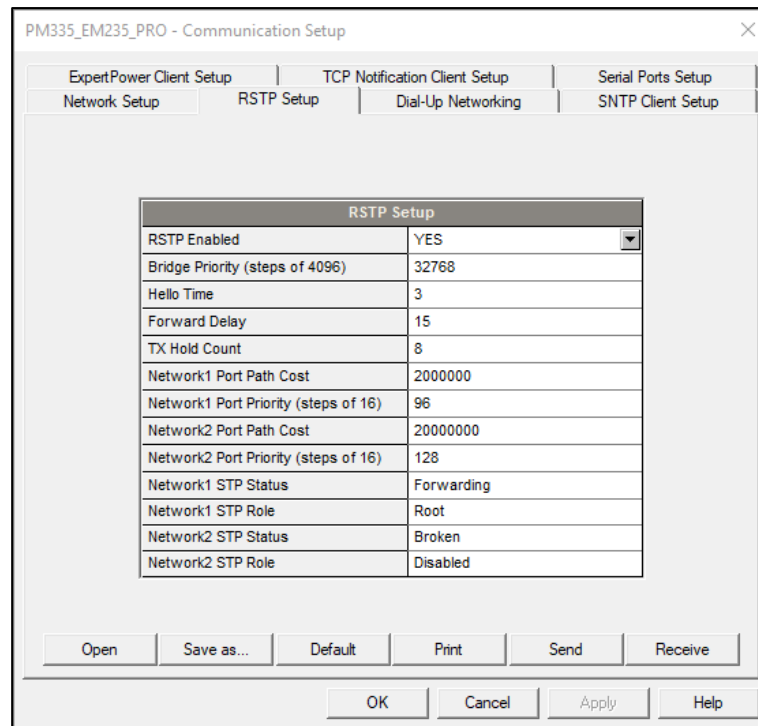

Figure 10-4

Parameter	Options	Default
Bridge Priority	4096 - 61440 in steps of 4096	32768
Hello Time	1 - 10	2
Forward Delay	4 - 30	15
TX Hold Count	1 - 10	6
Network Port Path Cost	1 - 200000000	200000
Port Priority	0 – 240 in steps of 16	128
STP Status / STP Role	Read-Only status notification	

#### NOTES:

- Changing the RSTP default settings may have significant impact on network health and stability. Consult with your network administrator
- The Meter supports as default 20 chained connected devices

### 10.1.4 Setting-Up SNTP Client

Select Communication Setup from the Meter Setup menu, and then click on the SNTP Client Setup tab.

The SNTP client can provide periodic synchronization of the meter clock with a publicly available SNTP server or with your local server if it supports this service.

To allow clock synchronization via SNTP, select SNTP as a clock synchronization source in Local Settings.

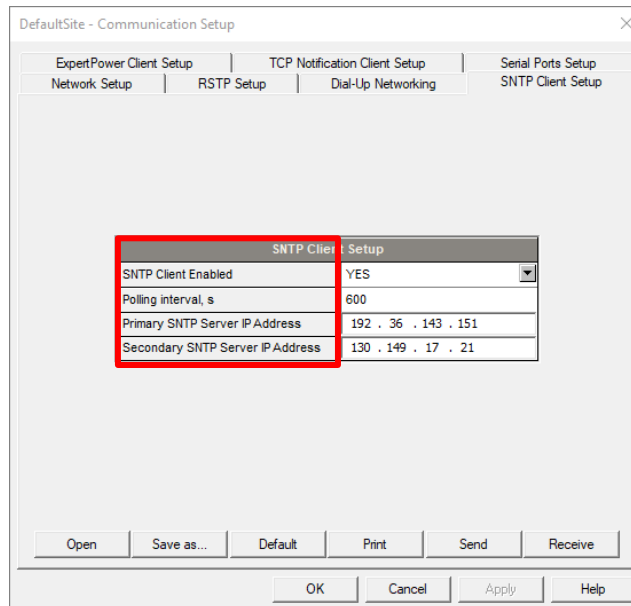

Figure 10-5

The following table lists available options

Table 13

Parameter	Options	Default	Description
SNTP Client Enabled	NO, YES	NO	Enables operations of the SNTP client
Polling interval, s	60-86400 s	600 s	The time remaining requesting time from the SNTP server
Primary SNTP Server IP Address		192.36.143.151	The IP address of the primary SNTP server
Secondary SNTP Server IP Address		130.149.17.21	The IP address of a secondary SNTP server in the event of temporary unavailability of the primary server

The default SNTP server IP addresses belong to Stockholm and Berlin university servers.

SNTP can work only out of the 1st Ethernet interface. Navigate to the Communication Setup > Network Setup. Verify that Network 1 has a valid IP address and a valid Gateway (that can reach the SNTP Server).

DefaultSite - Communication Setup

ExpertPower Client Setup | TCP Notification Client Setup | Serial Ports Setup  
 Network Setup | RSTP Setup | Dial-Up Networking | SNMP Client Setup

Network 1

Current Network Settings	
IP Address	192 . 168 . 99 . 111
Subnet Mask	255 . 255 . 255 . 0
Default Gateway	192 . 168 . 99 . 1
MAC Address	000544444444

Network Setup	
Device IP Address	192 . 168 . 99 . 111
Network Subnet Mask	255 . 255 . 255 . 0
Network Default Gateway	192 . 168 . 99 . 1
Use DHCP	NO
Secondary TCP Port	----
Primary DNS IP Address	0 . 0 . 0 . 0
Secondary DNS IP Address	0 . 0 . 0 . 0
Connection Idle Timeout, s	120
TCP Keepalive Time, s (0=inactive)	----
Device Address	----
Switch Mode	Separated

Open Save as... Default Print Send Receive

OK Cancel Apply Help

Figure 10-6

Navigate to General Setup > Local Settings. Activate the Clock synchronization and select SNTP as the method for synchronization. Make sure to set the Time Zone Offset, as the time provided by the SNTP is UTC.

DefaultSite - General Setup

Basic Setup | Device Options | Control/Alarm Setpoints | Analog Outputs | Analog Inputs | Digital Inputs  
 Display Setup | Relay Outputs | Counters | Transformer Correction | Periodic Timers | Local Settings

Time Zone Information	
Country	Default
Time Zone Offset, GMT +/- min	120
Daylight Savings Time (DST)	Disabled
DST Start Month	March
DST Start Week of Month	Second
DST Start Weekday	Sunday
DST Start Hour	2
DST End Month	November
DST End Week of Month	First
DST End Weekday	Sunday
DST End Hour	2
Date Order	N/A

Clock Synchronization

Time Synchronization Input	SNTP
----------------------------	------

Open Save as... Default Print Send Receive

OK Cancel Apply Help

Figure 10-7

### 10.1.5 Configuring eXpertPower Client

The PM17X PRO has an embedded eXpertPower™ client that provides communications with the eXpertPower™ server – the SATEC proprietary Internet services. Connections to the eXpertPower™ server are handled on a periodic basis.

To enter the Setup dialog, select the site from the list box on the PAS toolbar, select Communication Setup from the Meter Setup menu, and then click on the ExpertPower Client Setup tab.

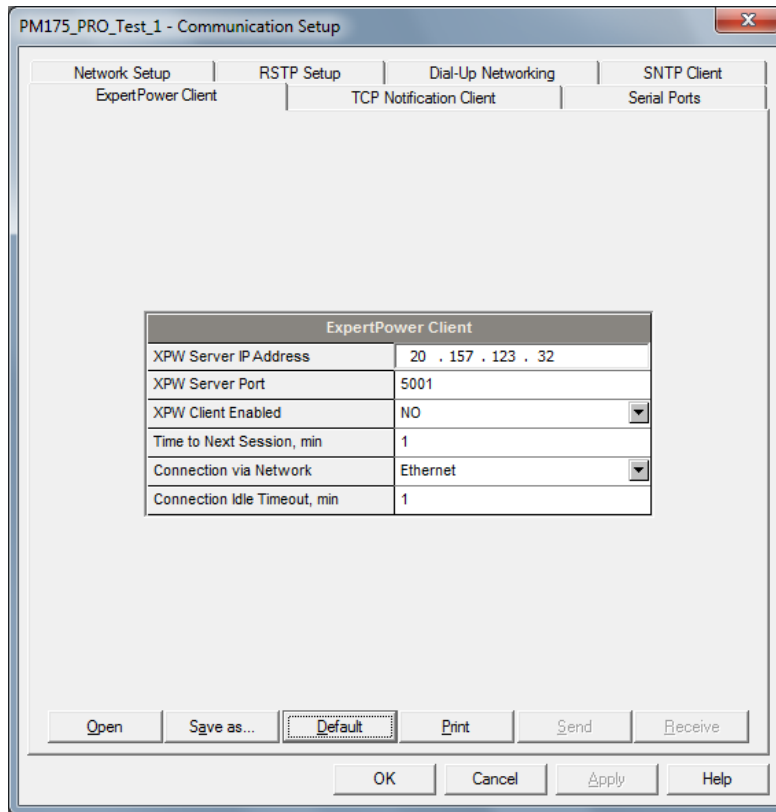

Figure 10-8 eXpertpower Client Setup Tab

The following table lists available options. Refer to your eXpertPower service provider for the correct eXpertPower settings.

Table 14

Parameter	Options	Default	Description
XPW Server IP Address		20.157.123.32	The IP address of the eXpertPower server
XPW Server Port	0-65535	5001	The TCP service port of the eXpertPower server
XPW Client Enabled	NO, YES	NO	Enables operations of the eXpertPower client
Time to Next Session, min	1-99999		The time remaining to the next connection session

**NOTES:**

1. If you do not use the eXpertPower™ service, do not enable the eXpertPower client in your device.
2. Do not change the connection period setting. The eXpertPower server updates it automatically.
3. eXpertPower works on ethernet port 1 and does not work on ethernet port 2

## 10.1.6 Setting Up TCP Notification Client

The TCP notification client can establish connections with a remote MODBUS/TCP server and send notification messages either on events, or periodically on a time basis.

To set up communications with a remote TCP Notification server, select Communication Setup from the Meter Setup menu, and then click on the TCP Notification Client Setup tab.

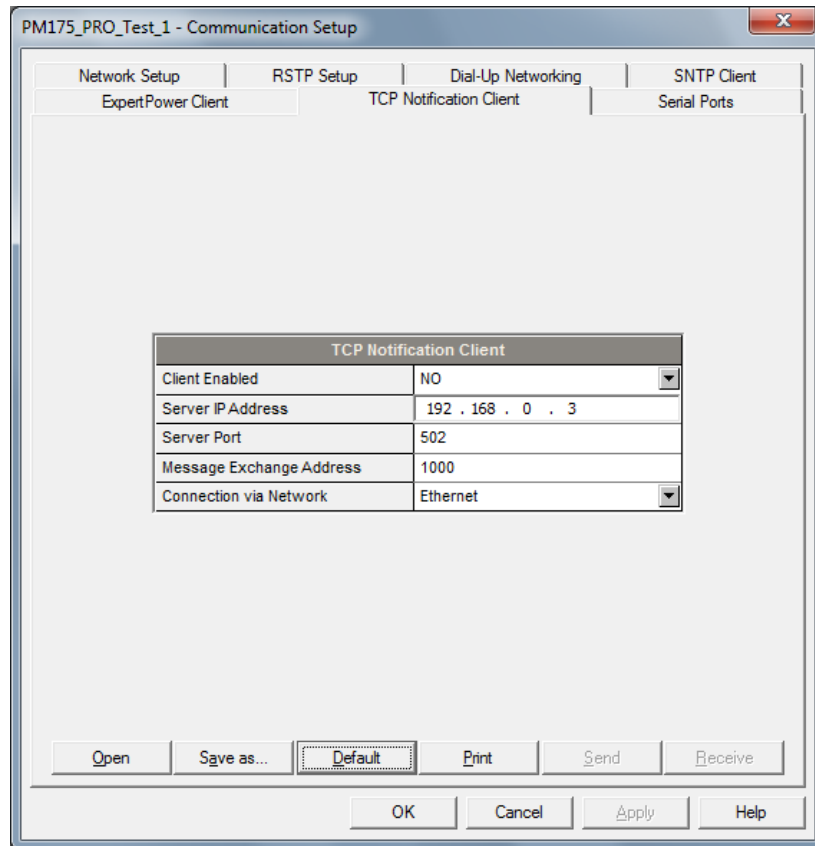

Figure 10-9 TCP Notification Client Setup Tab

The following table lists available client options.

Table 15: TCP Notification Client Setup Options

Parameter	Options	Default	Description
Client Enabled	NO, YES	NO	Enables operations of the notification client
Server IP Address		192.168.0.3	The IP address of the notification server
Server Port	0-65535	502	The TCP service port of the notification server
Message Exchange Address	0-65535	1000	The start address of a block of 16 MODBUS registers for receiving notification messages

Connections with a remote server are triggered via programmable setpoints. To send event notifications to a server, configure a setpoint to respond to desired triggers or to periodic time events and put the "Notification" action to the setpoint action list (see Configuring Alarm/Control Setpoints).

See the PM17X PRO Modbus Reference guide for more information on operation of the notification client and the notification message structure.

### 10.1.7 Meter Security

The PM17X PRO series provides 3-level password security for protecting meter setups and accumulated data from unauthorized changes. Meter readings are not software protected.

Access to particular setup and control items is granted depending on the security level of the password you entered. The passwords can be 1 to 8 digits long.

The PM17X PRO series is also equipped with terminal connections sealed cover to avoid unwanted electrical connections.

**Table 16: Security Level and User access**

Password	Security level	Access rights
Password 1	Low	Reset of billing and engineering maximum demands, and device diagnostics. Meter clock update. Display setup.
Password 2	Medium	TEST mode. Reset of counters and pulse counters. Communications setup. I/O operation setup and control. Memory and recorders setup. Billing/TOU system setup.
Password 3	High (Administration level)	Meter passwords setup. Basic device setup. Device energy and power options setup. Reset of conventional log files.

### Password Security

The setup menus are secured by 8-digit user passwords. Every time you enter programming mode, you are prompted for a correct password. The meter is primarily shipped with all passwords preset to “9” at the factory. See [Meter Security](#) in Chapter 8 for more information on the meter security levels.

It is recommended that you change the factory set passwords as fast as possible to protect your setups and accumulated data from unauthorized changes. See [Meter Security](#) in Chapter 8 on how to change passwords in your meter.

Enter the password as you enter numeric values. As you move to the next place, the digit entered is saved and then zeroed. If you missed a digit, you should re-type all preceding digits before you reach the missed place again.

Once the password is set to the desired value, press and hold the SELECT/ENTER button for more than 1 second. If the password you entered is correct, you move to the main device menu, otherwise you return back to the data display.

## Setup Menus and Access Rights

The PM17X PRO setup is menu-driven. The meter provides number of menus that allow local accessing a limited number of meter setups and control functions listed in the following table. Access to particular menus is granted depending on the security level of the password you entered.

**Table 17**

Menu Label	Menu Function	Security Level	
		View	Change
Reset	Reset of engineering maximum demands, device diagnostics, meter and battery operation time counters and failure counters	N/A	See Note below
RTC Setup	RTC clock setup	Low	Low
Display Setup	Display setup	Low	Low
Test Mode Setup	TEST/NORMAL mode switching and LED pulse rate setup for TEST mode (directly accessible via the TEST button)	Low	Medium
Basic Setup	Basic device setup	Low	High
Options Setup	Device options setup	Low	High
COM Setup	RS485 serial port setup	Low	Medium
Network Setup	Ethernet network setup	Low	Medium
Local Setup	Local settings	Low	Medium
Access Setup	Meter passwords setup	High	High
Loader	Launches flash download via a local serial port, local USB port, TCP/IP ethernet ports or GSM ( <i>future release</i> )	N/A	Medium
Reset Bill MD	Reset of billing maximum demands (accessible via the DEMAND RESET button)	N/A	Sealed
Master Reset	Reset of the billing data and files (protected by a security jumper)	N/A	Sealed

### NOTE

Access to the Reset menu entries is allowed depending on your security level as shown in Section in [Resetting Accumulators and Clearing Log Files](#) in Chapter 14.

If your security level does not allow access to a menu, it will not be listed in the main menu list, and you will not be able to highlight menu items that you are not allowed to change, but you can still view their present settings.

## 10.2 General Meter Setup

### 10.2.1 Basic Meter Setup

This section describes how to configure the PM17X PRO for your particular environment and application. Before operating your meter, provide the device with basic information about your electrical network.

#### Using PAS

Select General Setup from the Meter Setup menu. See the table below for the Basic Setup tab.

Basic Configuration	
Wiring Mode	4LN3
PT Ratio	1.0
PT Secondary (L-L), V	120.0
V4 PT Ratio	1.0
V4 PT Secondary, V	120.0
CT Primary, A	5
I4 CT Primary, A	5
Nominal Frequency, Hz	50
Phase Order	ABC
L1 Current Direction	Regular
L2 Current Direction	Regular
L3 Current Direction	Regular

Demand Setup	
Power Block Demand Period, min	15
Number of Blocks in Sliding Demand	1
Power Demand Sync Source	Meter Clock
Volt Demand Period, s	900
Amp. Demand Period, s	900
Harm. Demand Period, s	900

Figure 10-10 General Setup Dialog Box – Basic Setup Tab

The following table lists available client options.

**Table 18: Basic Setup Options**

Parameter	Options	Default	Description
Basic Configuration			
Wiring Mode	See Table 19	4Ln3	The wiring connection of the device
PT Ratio	1.0-6500.0	1.0	The phase potential transformer's primary to secondary ratio
PT Secondary (L-L), V	10-690	120	The rated linear voltage at the input of voltage channels of the device
CT Primary Current	1-50000 A	5 A	The primary rating of the phase current transformer
CT Secondary Current	1A, 5 A	5 A	The secondary rating of the phase current transformer
I4 CT Primary Current	1-50000 A	5 A	The primary rating of the fourth current transformer (can be neutral current)
I4 CT Secondary Current	1A, 5 A	5 A	The secondary rating of the fourth current transformer (can be neutral current)
Nominal Frequency	50,60 Hz	60 Hz	The nominal line frequency
Phase order	ABC, CBA	ABC	The normal phase sequence
L1 Current Direction	Regular, reverse	Regular	Current wiring direction
L2 Current Direction	Regular, reverse	Regular	Current wiring direction
L3 Current Direction	Regular, reverse	Regular	Current wiring direction
Demand Setup			
Power Block demand period, min	1, 2, 5, 10, 15, 20, 30, 60	15	The length of the demand period for power demand calculations
Number of Blocks in sliding window	1-15	1	The number of demand periods to be averaged for sliding window demands
Power demand sync source	Meter clock, DI1-DI48 (digital inputs 1-48)	Meter clock	The source input for synchronization of the demand intervals. If a digital input is specified as the source, a pulse front denotes the start of the demand interval
Volt demand period, s	0 - 9000 sec	900	The length of the demand period for ampere demand calculations
Amp. demand period, s	0 - 9000 sec	900	The length of the demand period for volt demand calculations
Harm. demand period	0 - 9000 sec	900	The length of the demand period for harmonic demand calculations

**Note:**

1. Always specify the wiring mode and transformer ratings prior to setting up setpoints and analog outputs.
2. The maximum value for the product of the phase CT primary current and PT ratio is 57,500,000. If the product is greater, power readings are zeroed.

Table 19 lists the available wiring modes.

Table 19: Wiring Modes

Wiring Mode	Description
3OP2	3-wire Open Delta using 2 CTs (2 element)
4LN3	4-wire Wye using 3 PTs (3 element), line-to-neutral voltage readings
3DIR2	3-wire Delta Direct Connection using 2 CTs (2 element)
4LL3	4-wire Wye using 3 PTs (3 element), line-to-line voltage readings
3OP3	3-wire Open Delta using 3 CTs (2½ element)
3LN3	4-wire Wye using 2 PTs (2½ element), line-to-neutral voltage readings
3LL3	4-wire Wye using 2 PTs (2½ element), line-to-line voltage readings
3BLN3	3-wire Broken Delta using 2 PTs, 3 CTs (2½ element), line-to-neutral voltage readings
3BLL3	3-wire Broken Delta using 2 PTs, 3 CTs (2½ element), line-to-line voltage readings

**Note:**

In 4LN3, 3LN3 and 3BLN3 wiring modes, the voltage readings for min/max volts and volt demands represent line-to-neutral voltages; otherwise, they will be line-to-line voltages. The voltage waveforms and harmonics in 4LN3, 3LN3 and 3BLN3 wiring modes represent line-to-neutral voltages; otherwise, they will show line-to-line voltages.

## 10.2.2 Device Options

The Device Options setup allows changing user-configurable device options or putting the meter into energy test mode.

### Using PAS

Select General Setup from the Meter Setup menu, and then click on the Device Options tab.

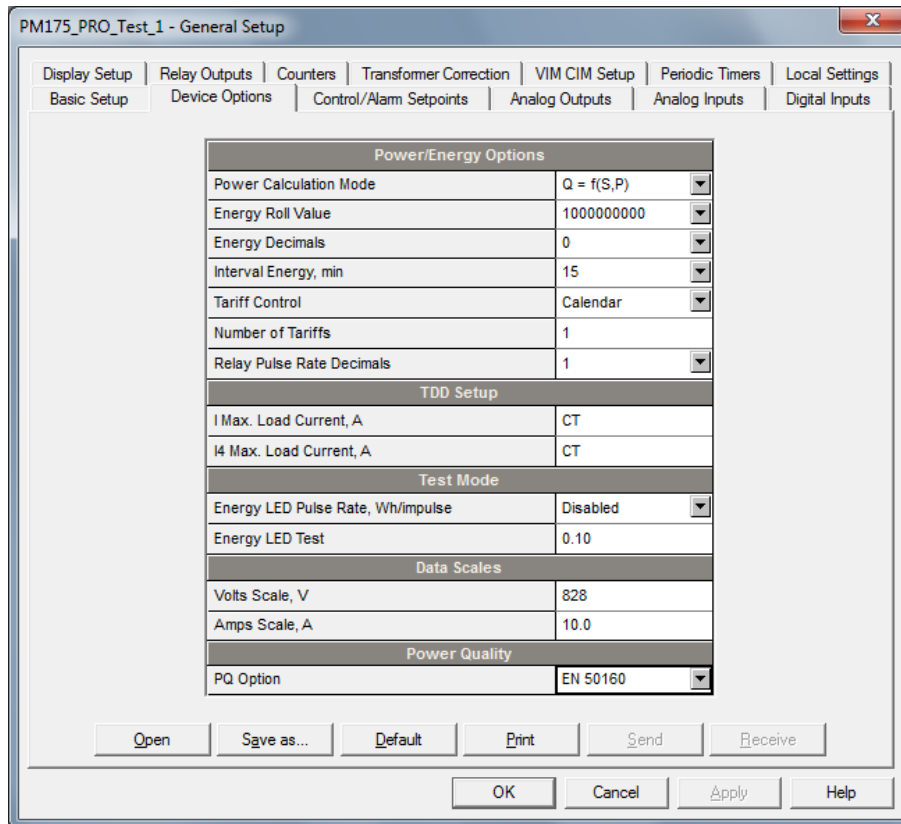

Figure 10-11 General Setup Dialog Box – Device Options Tab

Table 20 lists available device options.

Table 20: User-configurable Device Options

Parameter	Options	Default	Description
Power/Energy Options			
Power Calculation Mode	Reac = using reactive power $S=f(P, Q)$ , Nact = using non-active power $Q=f(S, P)$	$Q=f(S, Q)$	The method used for calculating reactive and apparent powers (see <a href="#">Power Calculation Modes</a> below)
Energy Roll Value	10000 kWh 100000 kWh 1000000 kWh	10000000	The value at which energy counters roll over to zero

Parameter	Options	Default	Description
	1000000 0 kWh  1000000 00 kWh  1000000000 kWh		
Energy Decimals <sup>2</sup>	0-3	0	Number of digits after decimal point
Interval Energy, min	5, 10, 15, 20, 30	15	Recorded accumulated energy in predefined interval
Tariff Control	Calendar, Communication, DI	Calendar	Define the Tariff control
Number of Tariffs	1-8	1	Define the number of tariffs
TDD Setup			
I Max. Load Current, A	0 - 10000 A	CT	The maximum demand load current for common current inputs (0 = CT primary)
I4 Max. Load Current, A	0 - 10000 A	CT	The maximum demand load current for I4 (0 = CT primary)
Test Mode			
Energy LED Pulse Rate, Wh/Impulse	0.01-0.4	0.1	LED pulse constant - the amount of accumulated energy (in secondary readings) giving one pulse via "kWh" and "kvarh" LEDs.
Energy Test Mode	Disabled  Wh pulses  varh pulses	Disabled	Setting this option puts the meter into the energy test mode (see <a href="#">Energy Pulse LED</a> in Chapter 8)
Data Scale			
Volts Scale, V	10-828V	828 V	The allowed, in secondary volts. See <a href="#">Data Scales</a> in Chapter 23.
Amps Scale, A	1.0-10.0 A	10	The maximum current scale allowed, in secondary amps. See <a href="#">Data Scales</a> in Chapter 23.

## Power Calculation Modes

The power calculation mode option allows you to change the method for calculating reactive and apparent powers in presence of high harmonics. The options work as follows:

When the reactive power calculation mode is selected, active and reactive powers are measured directly and apparent power is calculated as:

$$S = \sqrt{P^2 + Q^2}$$

This mode is recommended for electrical networks with low harmonic distortion, commonly with THD < 5% for volts, and THD < 10% for currents. In networks with high harmonics, the second method is preferable.

When the non-active power calculation mode is selected, active power is measured directly, apparent power is taken as product  $S = V \times I$ , where V and I are the RMS volts and amps, and reactive power (called non-active power) is calculated as:

$$Q = \sqrt{S^2 - P^2}$$

<sup>2</sup> The number of digits after decimal points is part of total of digits of Energy roll value

### 10.2.3 Transformer Correction

While using external CT meter option, transformer correction allows you to compensate ratio and phase angle inaccuracies of the user voltage and current instrument transformers.

#### Using PAS

Select General Setup from the Meter Setup menu, and then click on the Transformer Correction tab.

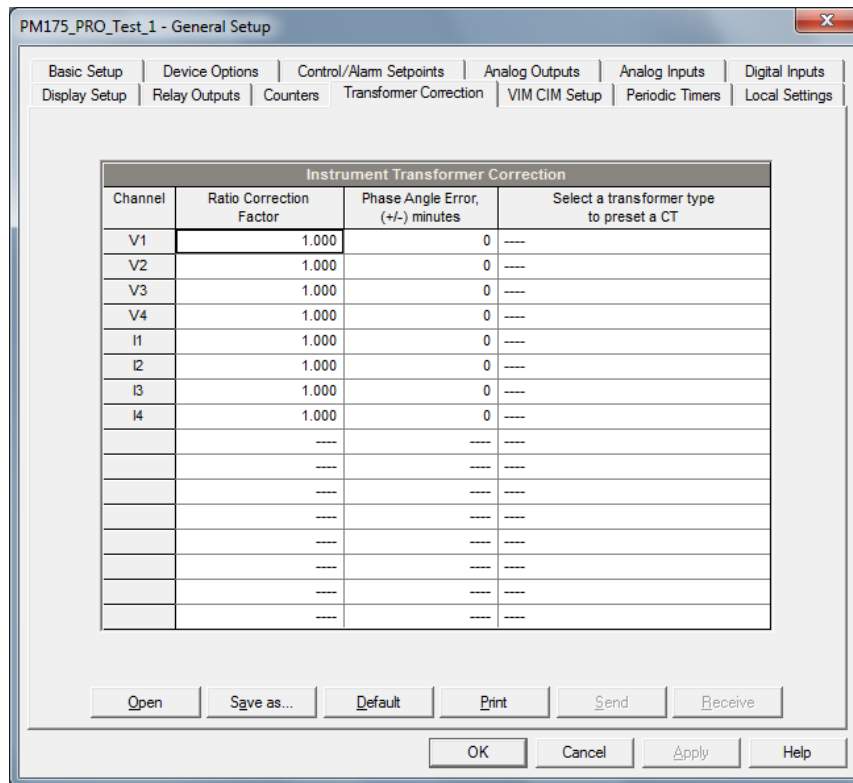

Figure 10-12 General Setup Dialog Box – Transformer Correction Dialog Box

The following table lists available options.

Table 21

Label	Parameter	Options	Default	Description
Ratio V1-V3	V1-V3 voltage transformer ratio correction factor	0.700 to 1.300	1.000	The ratio of the true transformer ratio to the marked ratio.
Angle V1-V3	V1-V3 transformer phase angle error, minutes	-600 to 600	0	The phase displacement, in minutes, between the primary and secondary values. The phase angle of a voltage transformer is positive when the secondary value leads the primary value.
Ratio I1-I4	I1-I3 current transformer ratio correction factor	0.700 to 1.300	1.000	The ratio of the true transformer ratio to the marked ratio.
Angle I1-I4	I1-I3 transformer phase angle error, minutes	-600 to 600	0	The phase displacement, in minutes, between the primary and secondary values. The phase angle of a current transformer is positive when the secondary value leads the primary value.

## 10.2.4 Configuring Digital Inputs

The PM17X PRO can be provided with one 8DI digital inputs that can be linked to control setpoints to give an indication on input status change (see Configuring Alarm/Control Setpoints), or can be linked to general pulse counters to count incoming pulses (see Configuring Counters). They can also be linked to the Billing/TOU registers to count pulses from external watt meters or gas and water meters.

### Using PAS

Select General Setup from the Meter Setup menu, and then click on the Digital Inputs tab.

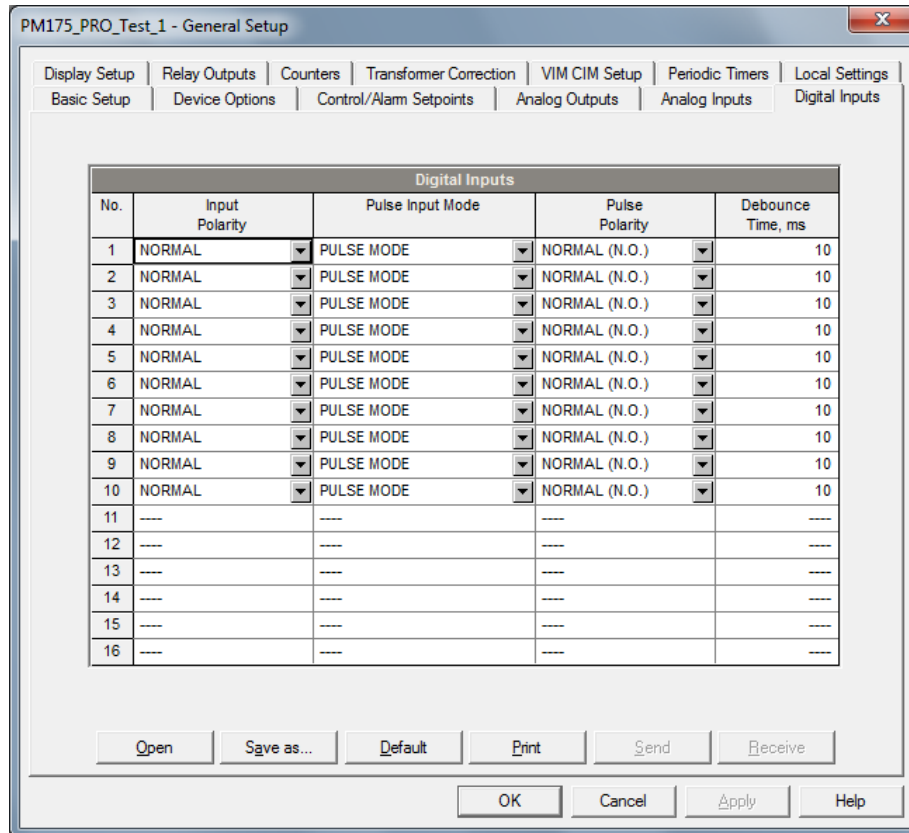

Figure 10-13 General Setup Dialog Box – Digital Inputs Dialog Box

The available options are shown in Table 22.

Table 22: Digital Input Options

Parameter	Options	Default	Description
Pulse Input Mode	PULSE MODE KYZ MODE	PULSE MODE	In pulse mode, either leading, or trailing edge of the input pulse is recognized as an event. In KYZ mode, both leading and trailing edges of the input pulse are recognized as separate events.
Pulse Polarity	NORMAL (N.O.), INVERTING (N.C.)	NORMAL	For the normal polarity, the open to closed transition is considered a pulse. For the inverting polarity, the closed to open transition is considered a pulse. It has no meaning in KYZ mode where both transitions are used.
Debounce Time	1-100 ms	10 ms	The amount of time while the state of the digital input should not change to be recognized as a new state. Too low debounce time could produce multiple events on the input change.

The debounce time is applied the same for all digital inputs. If you change the debounce time for a digital input, the same debounce time is automatically assigned to the others.

## 10.2.5 Configuring Relay Outputs

The PM17X PRO can be provided with one to seven (depend on DI/O module type) optional relay outputs. Each relay can be operated either locally from the alarm/control setpoints in response to an event or by a remote command sent through communications. It can also be linked to an internal pulse source to produce energy pulses.

### Using PAS

Select General Setup from the Meter Setup menu, and then click on the Relay Outputs tab.

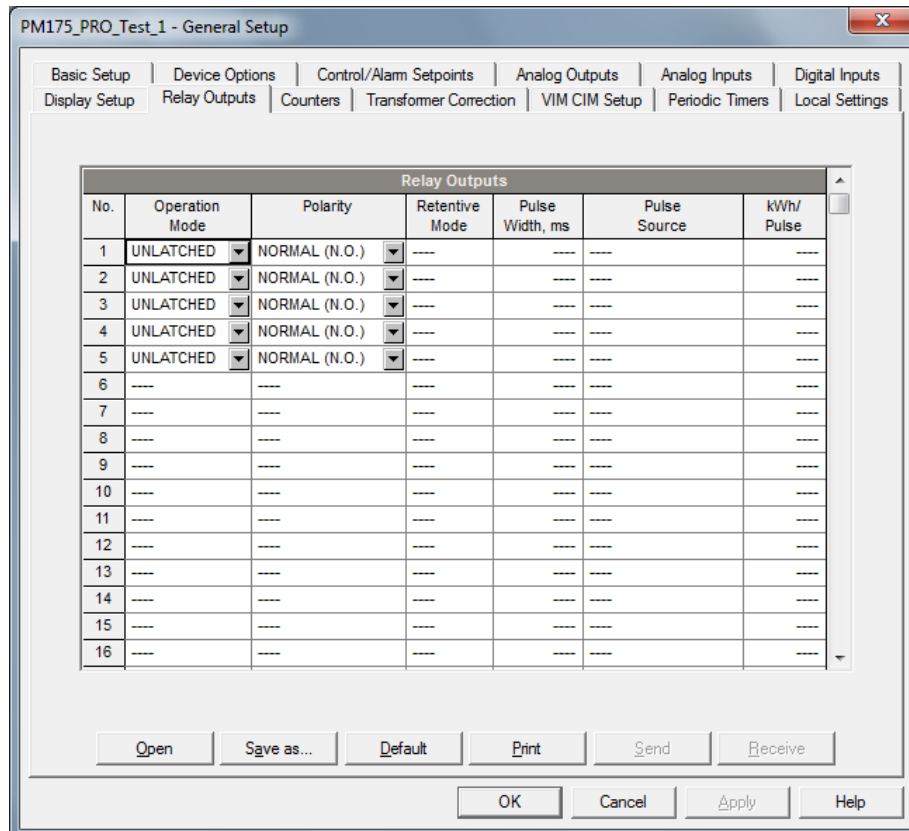

Figure 10-14 General Setup Dialog Box – Relay Outputs Tab

Table 23: Relay Output Options

Option	Format/Range	Default	Description
Mode Operation	Unlatched	Unlatched	Defines the behavior of the relay in response to local and remote commands
	Latched Pulse		Unlatched mode: the relay goes into its active state when the control setpoints is in active (operated) state, and returns into its non-active state when the setpoints is released.
	KYZ		Latched mode: the relay goes into its active state when the control setpoints goes into active state and remains in the active state until it is returned into its non-active state by another setpoints or by a remote command.
			Pulse mode: the relay goes into its active state for the specified time, goes into non-active state for the specified time and remains in the non-active state.
			KYZ mode: the relay generates transition pulses. The relay changes its output state upon each command and remains in this state until the next command.
Polarity	Normal (N.O.)	Normal	Defines whether the relay is energized or de-energized in its non-active and active (operated) states.
	Inverting (N.C.)		With normal polarity, the relay is normally de-energized in its non-active state and is energized in its active (operated) state.
			With inverting polarity, the relay is normally energized in its non-active state and is de-energized in its active (operated) state. It is called sometimes failsafe relay operation.
Retentive mode	Checked	Unchecked	This option is only applicable for latched relays.
	Unchecked		Normally, when retentive mode is OFF, the relay is always returned into its non-active state upon power up.
			If the relay is set to be retained, the device restores its status to what it was prior to loss of power.
Pulse width	10-1000 ms	100 ms	The amount of time the pulse relay stays in active state when generating a pulse. The actual pulse width is a multiple of the 1/2-cycle time rounded to the nearest bigger value. The minimum pause time between pulses is equal to the pulse width.

Pulse source	None	---	Links the pulse relay to the internal pulse event that is to be retransmitted through the relay output as a pulse with a predefined width. The relay must be set into either pulse, or KYZ mode.
	kWh IMP PULSE		
	kWh EXP PULSE		
	kWh TOT PULSE		
	kvarh IMP PULSE kvarh EXP PULSE		
	kvarh TOT PULSE		
	kVAh TOT PULSE		

## Generating Energy Pulses through Relay Outputs

To generate energy pulses through a relay output:

1. Set a relay to either pulse, or KYZ mode, and then select a polarity (active pulse edge) for energy pulses and a pulse width.
2. Select a source energy accumulator and the pulse rate for your output.
3. Send your new setup to the meter.

## 10.2.6 Configuring Analog Outputs

The meter can be ordered with an optional analog output module that contains 4 outputs with options for 0-1mA,  $\pm 1$ mA, 0-20mA and 4-20mA current outputs.

### Using PAS

Select General Setup from the Meter Setup menu, and then click on the Analog Outputs tab.

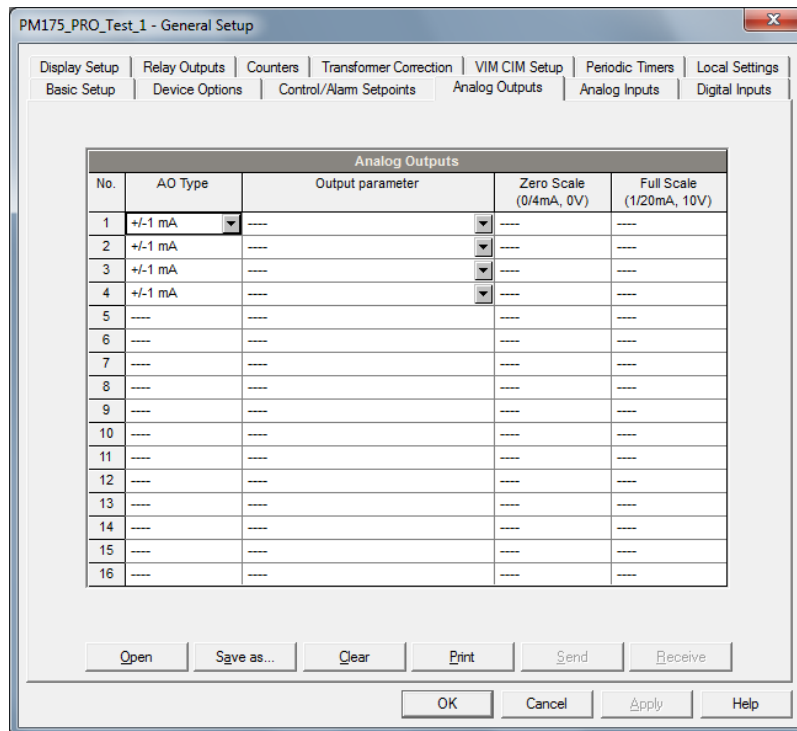

Figure 10-15 General Setup Dialog Box – Analog Outputs Tab

The available analog output options are described in Table 24.

Table 24: Analog Output Options

Option	Range	Description
AO type	0-1mA $\pm 1$ mA 0-20mA 4-20mA	The analog output type. When connected to the meter, shows the actual AO type received from the device. When working off-line, select the analog output option corresponding to your analog module.
Output parameter	See Chapter 19	Selects the measured parameter to be transmitted through the analog output channel.
Zero scale		Defines the low engineering scale (in primary units) for the analog output corresponding to a lowest (zero) output current (0 or 4 mA)
Full scale		Defines the high engineering scale (in primary units) for the analog output corresponding to a highest output current (1 or 20 mA)

When you select an output parameter for the analog output channel, the default engineering scales are set automatically. They correspond to the maximum available scales. If the parameter actually covers a lower range, you can change the scales to provide a better resolution on an analog output.

## Scaling Non-Directional Analog Outputs

For non-directional analog outputs with a 0-1mA, 0-20mA or 4-20mA current option, you can change both zero and full engineering scales for any parameter. The engineering scale need not be symmetrical.

## Scaling Directional Power Factor

The engineering scale for the signed power factor emulates analog power factor meters.

The power factor scale is -0 to +0 and is symmetrical with regard to  $\pm 1.000$  ( $-1.000 \equiv +1.000$ ). The negative power factor is scaled as -1.000 minus the measured value, and non-negative power factor is scaled as +1.000 minus the measured value. To define the entire power factor range from -0 to +0, the default scales are specified as -0.000 to 0.000.

## Scaling $\pm 1$ mA Analog Outputs

Programming engineering scales for directional  $\pm 1$  mA analog outputs depends on whether the output parameter represents unsigned (as volts and amps) or signed (as powers and power factor) values.

For an unsigned output value, you can change both zero and full engineering scales.

For a signed (directional) value, you should only provide the engineering scale for the +1 mA output current.

The engineering scale for the 0 mA output current is always equal to zero for all values except the signed power factor, for which it is set to 1.000 (see [Scaling Directional Power Factor](#) above).

The meter does not allow access to the low scale setting if the parameter is directional. Whenever the sign of the output parameter is changed to negative, the meter automatically uses the full engineering scale setting for +1 mA with a negative sign.

## Scaling Analog Outputs for 0-2 mA and $\pm 2$ mA

The 0-1 mA and  $\pm 1$  mA current outputs provide a 100% overload, and actually output currents up to 2 mA and  $\pm 2$  mA whenever the output value exceeds the engineering scale you set for the 1 mA or  $\pm 1$  mA.

The output scales for 0-1 mA and  $\pm 1$  mA analog outputs are programmed for 0 mA and +1 mA regardless of the required output current range.

To use the entire output range of 2 mA or  $\pm 2$  mA, set the analog output scales as follows:

- 0-2 mA: set the 1 mA scale to  $\frac{1}{2}$  of the required full scale output for uni-directional parameters, and set the 0 mA scale to the negative full scale and the 1 mA scale to zero for bi-directional parameters.
- $\pm 2$  mA: set the 1 mA scale to  $\frac{1}{2}$  of the required full-scale output for both uni-directional and bi-directional parameters.

For example, to provide the 0 to 2 mA output current range for Volts measured by the meter in the range of 0 to 120V, set the 1 mA scale to 60V; then the 120V reading will be scaled to 2 mA.

## 10.2.7 Using Counters

The PM17X PRO has 32 nine-digit signed counters that count different events. Each counter is independently linked to any digital input and count input pulses with a programmable scale factor. You can link a number of digital inputs to the same counter. Each counter can be incremented or decremented through the Control Setpoints in response to any internal or external event.

### Using PAS

Select General Setup from the Meter Setup menu, and then click on the Counters tab.

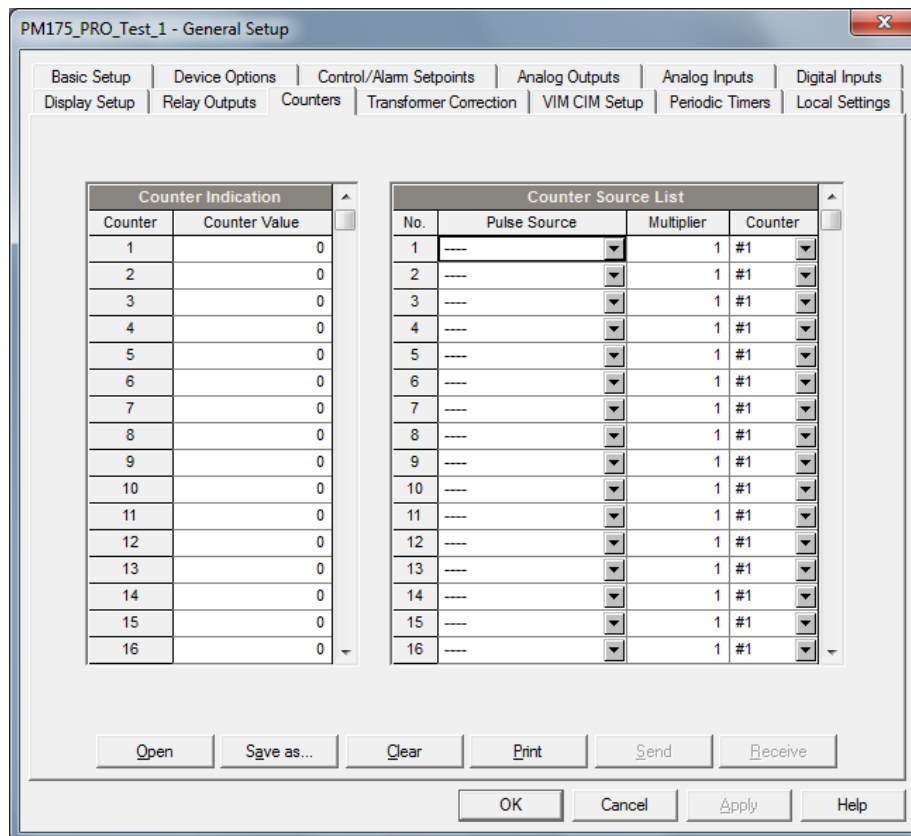

Figure 10-16 General Setup Dialog Box – Pulse/Event Counters

Table 25 lists available counter options.

Table 25: Counter Options

Option	Range	Default	Description
Pulse Input	None, DIGITAL INPUT #1 - #26	None	Links a digital input to the counter
Multiplier	1-10000	1	The value added to the counter when a pulse is detected on the pulse source input
Counter Value			Displays the present counter contents

You can preset a counter to a required value or clear it without affecting the counter setup.

**To preset or clear a counter:**

1. Click the Online button on the PAS toolbar before accessing the setup dialog box.
2. Type in the required value into the Counter Value field.
3. Click Send

## 10.2.8 Using Periodic Timers

The PM17X PRO has 16 programmable timers that are used for periodic recording and triggering operations on a time basis through the Control Setpoints. When a pre-programmed timer interval is expired, the timer generates an internal event that can trigger any setpoints (see [Using Control Setpoints](#)). The programmable time interval can be from 1/2 cycle and up to 24 hours.

To configure the device timers, select General Setup from the Meter Setup menu, and then click on the Periodic Timers tab.

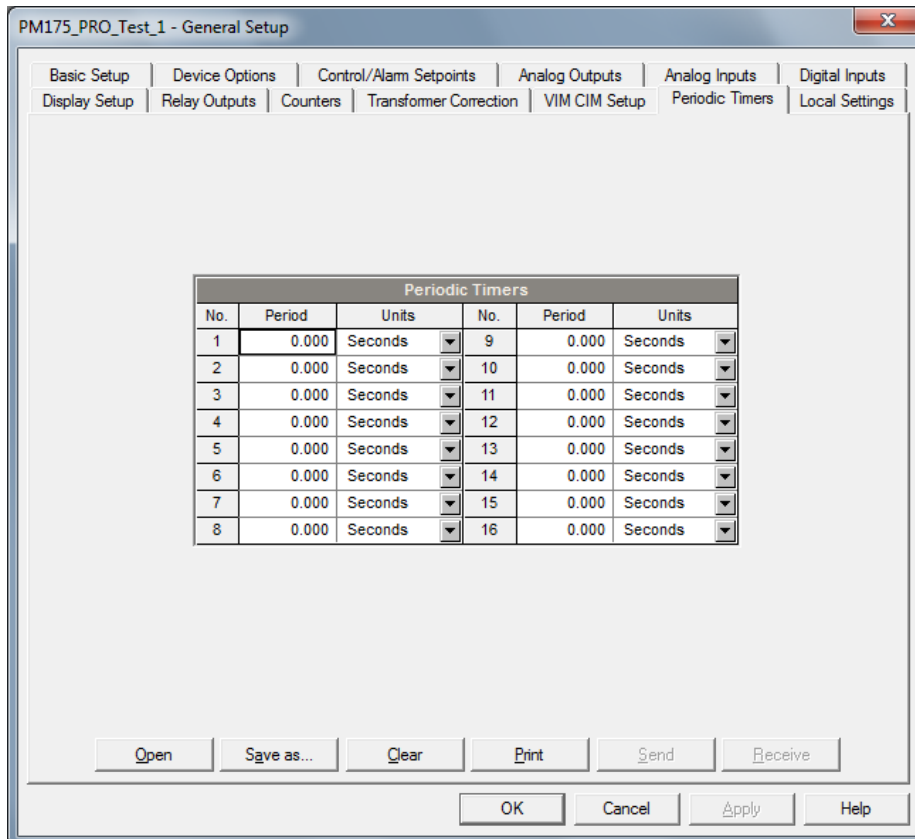

Figure 10-17 General Setup Dialog Box – Periodic Timers

Table 26 lists available counter options.

Table 26: Periodic Timers options

Option	Range	Default	Description
Period	0 = disabled 0.010 - 100,000.000 sec 0.500 - 100,000.000 cycles	0	The timer period
Units	Seconds, Cycles	Seconds	The time units

Seven timers from Timer #10 through Timer #16 are factory preset and cannot be re-programmed. They are primarily intended for the use with the Power Quality recorder. Other timers can be programmed by the user.

To run a periodic timer, select the desired time unit and specify a non-zero time period.

To stop a timer, set the time period to zero.

## 10.2.9 Using Control Setpoints

The PM17X PRO has an embedded logical controller that runs different actions in response to user-defined internal and external events. Unlike a PLC, the PM17X PRO uses a simplified programming technique based on setpoints that allows the user to define a logical expression based on measured analog and digital values that produces a required action.

The PM17X PRO provides 64 control setpoints with programmable operate and release delays. Each setpoint evaluates a logical expression with up to four arguments using OR/AND logic. Whenever an expression is evaluated as “true”, the setpoint performs up to four concurrent actions that can send a command to the output relays, increment or decrement a counter, or trigger a recorder.

To program the setpoints, select General Setup from the Meter Setup menu, and then click on the Control/Alarm Setpoints tab.

PM175\_PRO\_Test\_1 - General Setup

Display Setup | Relay Outputs | Counters | Transformer Correction | VIM CIM Setup | Periodic Timers | Local Settings  
 Basic Setup | Device Options | Control/Alarm Setpoints | Analog Outputs | Analog Inputs | Digital Inputs

Setpoint No. 1

Setpoint Triggers					
OR/AND	Input Group	Trigger Parameter	Relation	Operate limit	Release limit
OR	PHASE (1 cycle)	V1	>=	132	130
OR	PHASE (1 cycle)	V2	>=	132	130
OR	PHASE (1 cycle)	V3	>=	132	130
OR	----	----	----	----	----
OR	----	----	----	----	----
OR	----	----	----	----	----
OR	----	----	----	----	----
OR	----	----	----	----	----

Actions			
No.	Action	Target	Parameter
1	EVENT LOG	OPER	----
2	DATA LOG	#1	----
3	WAVEFORM LOG	#1	----
4	----	----	----

Delays, s	
Operate delay	0.000
Release delay	0.000

Open Save as... Clear Clear All Print Send Receive

OK Cancel Apply Help

Figure 10-18 General Setup Dialog Box – Control/Alarm Setpoints

The available setpoints options are described in the following table:

**Table 27: Control/Alarms Setpoints options**

Option	Format/Range	Description
Setpoints Triggers		
OR/AND	OR, AND	The logical operator for the trigger
Input group		The trigger parameter group (see chapter 11)
Trigger parameter		The trigger parameter that is used as an argument in the logical expression (see chapter 11)
Relation	<=, >=, =, <>, Delta, Delta+, Delta-, rDelta, rDelta+, rDelta-	The relational operator used in the conditional expression for the trigger
Operate limit		The threshold (in primary units) at which the conditional expression would be evaluated to true. Not applicable for digital triggers.
Release limit		The threshold (in primary units) at which the conditional expression would be evaluated to false. Defines the hysteresis for analog triggers. Not applicable for digital triggers.
Setpoints Actions		
Action		The action performed when the setpoints expression is evaluated to true (see chapter 10)
Target		The optional action target
Parameter		The optional action argument (reserved)
Delays		
Operate delay	0-10,000.000 sec	The time delay before operation when the operate conditions are fulfilled
Release delay	0-10,000.000 sec	The time delay before release when the release conditions are fulfilled

The logical controller provides very fast response to events. The scan time for all setpoints is 1/2 cycle time (8 ms at 60Hz and 10 ms at 50 Hz).

Setpoints #1 is factory preset to provide standard periodic data logs on a 15-minute time basis. It is linked to the device clock and runs Data logs #1 and #2 at 15-minute boundaries of an hour.

## Using Logical Expressions

Logical operators OR/AND are treated in a simplified manner. They have no specific priority or precedence rules.

Any trigger condition bound to the logical expression by the OR operator and evaluated as “true” overrides any preceding condition evaluated as “false”. Similarly, any trigger condition evaluated as “false” and bound by the AND operator overrides any condition evaluated before it as “true”.

To avoid confusion, it is recommended not to alternate different logical operators in one expression. Instead, bring all conditions that use the same logical operator together at one side of the expression, and the others - at the opposite side.

To explicitly override all other conditions with the critical trigger, put it at the end of the expression using the OR operator if you want the setpoints to be operated anyway when the trigger condition is asserted, and with the AND operator, if the setpoints should not be operated while the critical trigger is not asserted.

## Using Numeric Triggers

For numeric (analog) triggers, a setpoints allows you to specify two thresholds for each trigger to provide hysteresis (dead band) for setpoints operations. The Operate Limit defines the operating threshold, and the second Release Limit defines the release threshold for the trigger. The trigger thresholds are always specified in primary units.

If you use relational operators as " $\leq$ " (under or equal) or " $\geq$ " (over or equal), always specify a correct Release Limit for the trigger. If you do not want to use hysteresis, set the Release Limit to the same as the Operate Limit.

With the "Delta" operator, the setpoints is operated when the absolute value of the difference between the last reported value and the current value exceeds the specified threshold

## Using Binary Triggers

Binary (digital) triggers, as digital inputs, relays, or internal static and pulsed events, are tested for ON (closed/set) or OFF (open/cleared) status. Min/Max log parameters can be tested for a NEW event that is asserted when a new minimum or maximum value is recorded for the parameter since the last time it was checked.

The binary events are divided into two types: static events and pulsed events. Static events are level-sensitive events. A static event is asserted all the time while the corresponding condition exists. Examples are digital inputs, relays and internal static events generated by the device diagnostics, metering procedures, and Power Quality recorder.

Pulsed events are edge-sensitive events with auto-reset. A pulsed event is generated for a trigger only once when a positive transition edge is detected on the trigger input. The examples of pulsed events are pulse inputs (transition pulses on the digital inputs), internal pulsed events (energy pulses and time interval pulses), and events generated by the interval timers. The logical controller automatically clears pulsed events at the end of each scan, so that triggers that used pulsed events are prevented from being triggered by the same event once again.

## Using Event Flags and Virtual Relays

The PM17X PRO has 16 common binary flags, called event flags, which can be individually set, cleared and tested through setpoints or remotely.

Event flags can be used in different applications, for example, to transfer events between setpoints in order to expand a logical expression or a list of actions that have to be done for a specific event, or to remotely trigger setpoints actions from the SCADA system or from a PLC.

In the same way, any of the 32 device relays that is not actually present in your device (it is called a virtual relay) can be used to transfer events from one setpoints to others, or to indicate events to the setpoints from the external system.

## Using Interval Timers

The PM17X PRO has 16 interval timers that are commonly used for periodic recording of interval data at the time of the fault or in the presence of other events detected by setpoints. Some of the timers are factory preset for use with the Power Quality recorder, and others can be programmed to generate periodic events at user-defined intervals (see [Using Periodic Timers](#)).

Interval timers are not synchronized with the clock. When you run a timer, it generates a pulsed timer event that can trigger a setpoints if you have put the timer into a list of the setpoints triggers. When the setpoints event is asserted, the timer is restarted, and then generates the next timer event when the timer interval expires.

If you want to record interval data at predefined intervals without linking to other events, just select a timer as a setpoints trigger and specify in the setpoints actions list a data log file you want to use for recording. If you want the periodic data to be recorded in presence of a specific event, select triggers that identify your event, and then add the timer at the end of the trigger list using the AND operator.

## Using Time Triggers

If you want the setpoints actions to be synchronized with the clock, for example, to provide synchronous recording interval data each 15 minutes or each hour, or to output time pulses through relay contacts, use the time triggers that generate static events synchronized to the device clock.

You can exercise the default setting for Setpoints #1 in your device as an example of using time triggers. The setpoints is pre-programmed for data profiling at 15-minute intervals using data logs #1 and #2.

## Using the Voltage Disturbance Trigger

The voltage disturbance trigger (found under the VOLT DISTURB name in the SPECIAL INPUTS trigger group) detects all types of the voltage waveshape faults on any phase caused by fast transient voltages. You can use it to record disturbances if you want to do this differently from the way the Power Quality recorder does it.

The operate threshold for the voltage disturbance trigger defines the maximum allowable voltage deviation from a steady-state level above which the device declares a waveshape fault. It is specified as a percent of the nominal voltage. Using PAS you may select volts units or % of nominal voltage from the "Preferences" tab in the "Tools/Options dialog (see [Voltage Disturbance Units](#) in Chapter 17). The trigger does not respond to slow voltage variations whenever the voltage rise above or drop below the specified threshold takes longer than 1 cycle time.

## Delaying Setpoints Operations

Two optional delays can be added to each setpoints to extend monitoring setpoints triggers for a longer time before making a decision on whether the expected event occurred or not. When a delay is specified, the logical controller changes the setpoints status only if all conditions are asserted for a period at least as long as the delay time.

Although a delay can be specified with a 1-ms resolution, the actual value is aligned at a lower 1/2-cycle time boundary.

Note that you cannot use delays with pulsed events since they are cleared immediately and do not longer exist on the next setpoints scan.

## Using Setpoints Events and Actions

When a setpoints status changes, i.e., a setpoints event is either asserted or de-asserted, the following happens in your device:

The new setpoints status is logged to the setpoints status register that can be monitored from the SCADA system or from a programmable controller in order to give an indication on the expected event.

The operated setpoints status is latched to the setpoints alarm latch register, which is remotely accessible. The register holds the last setpoints alarm status until it is explicitly cleared.

Up to four programmable actions can be performed in sequence on setpoints status transition when a setpoints event is asserted.

Generally, setpoints actions are performed independently for each setpoints and can be repeated a number of times for the same target. The exceptions are relay operations, data logging and waveform logging that are shared between all setpoints using an OR scheme for each separate target.

A relay output is operated when one of the setpoints linked to the relay is activated and stays in the operated state until all of these setpoints are released (except for latched relays that require a separate release command to be deactivated).

Data logging and waveform logging directed to the same file are done once for the first setpoints among those that specify the same action, guaranteeing that there will not be repeated records related to the same time.

## Recording Setpoints Events

Time-tagged setpoints events can be recorded both to the Event log, and to the Sequence-of-Events log files if you put corresponding actions into the setpoints action list.

If you link a setpoints to the Sequence-of-Events recorder, all setpoints transition events are recorded to the Sequence-of-Events log by default. If you select to record setpoints operations into the Event log, define in the action target box which transition events you want to be recorded: when the setpoints is operated, when it is released, or both events. The Event recorder puts into a log file a separate record for each active trigger caused a setpoints status transition, and a separate record for each action done on the setpoints activation (except for logging actions that are not recorded to the Event log).

If you run a number of recorders from the same setpoints action list, it is recommended that you put the Event log action before others in order to allow other recorders to use the event sequence number given to the event by the Event recorder.

## Cross Triggering Setpoints

When a setpoints is operated, the device sends a broadcast UDP message across the network using one of the sixteen triggering channels. All devices that have a setpoints programmed to respond to this trigger act in response. The cross-triggering delay is normally less than one cycle time.

To send a cross-triggering message, put an "EXT TRIGGER" action into the setpoints actions list and select one of the sixteen triggering channels as a target. In all devices, which you want to respond to this message, select an "EXT TRIGGER" group in the setpoints triggers list and specify the channel through which the device would receive messages.

## Power Quality Event Indication and Cross Triggering

When the PQ recorder detects a power quality fault, it generates the specific internal event PQ EVENT that can be monitored through a control setpoints to give a fault indication via relay contacts. The event can be found under the STATIC EVENTS group in the setpoints trigger list.

The power quality fault signal is used for cross triggering multiple recorders through a dedicated digital input in order to simultaneously record disturbances at different locations. External triggering of the Waveform and Data recorders for recording disturbance data can be done through a setpoints programmed to monitor the status of a digital input. For more information on cross triggering, see Fault Indication and Cross Triggering.

## 10.3 Display Setup

### 10.3.1 Updating the meter Clock

This display setup menu allows the user to setup the localization details.

#### Using PAS

Ensure that the On-line button on the PAS toolbar is checked, and then select RTC from the Monitor menu or click on the PAS toolbar Real-Time Clock Button.

The RTC dialog box displays the current PC date and time and the time in your meter.

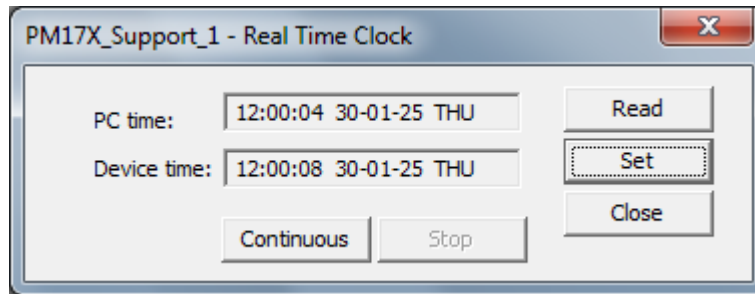

Figure 10-19 Real Time Clock Dialog Box – Time and Date setup

To synchronize the meter clock with the PC clock, click Set.

### 10.3.2 Local Time Settings

This setup allows you to select the external time synchronization source and daylight savings time options.

#### Daylight Savings Time

The daylight savings time option is disabled in the PM17X PRO by default, and the default daylight savings time change points are set for the U.S.A. When the daylight savings time is enabled, the PM17X PRO automatically adjusts the device clock at 02.00 AM when daylight savings time begins/ends.

If the daylight savings time option is disabled, you need to manually adjust the device clock for daylight savings time. This setup allows you to specify your time zone, daylight saving time, and clock synchronization options.

## Using PAS

To configure the local time options in your device, select the device site from the list box on the PAS toolbar, select General Setup from the Meter Setup menu, and then click on the Local Settings tab.

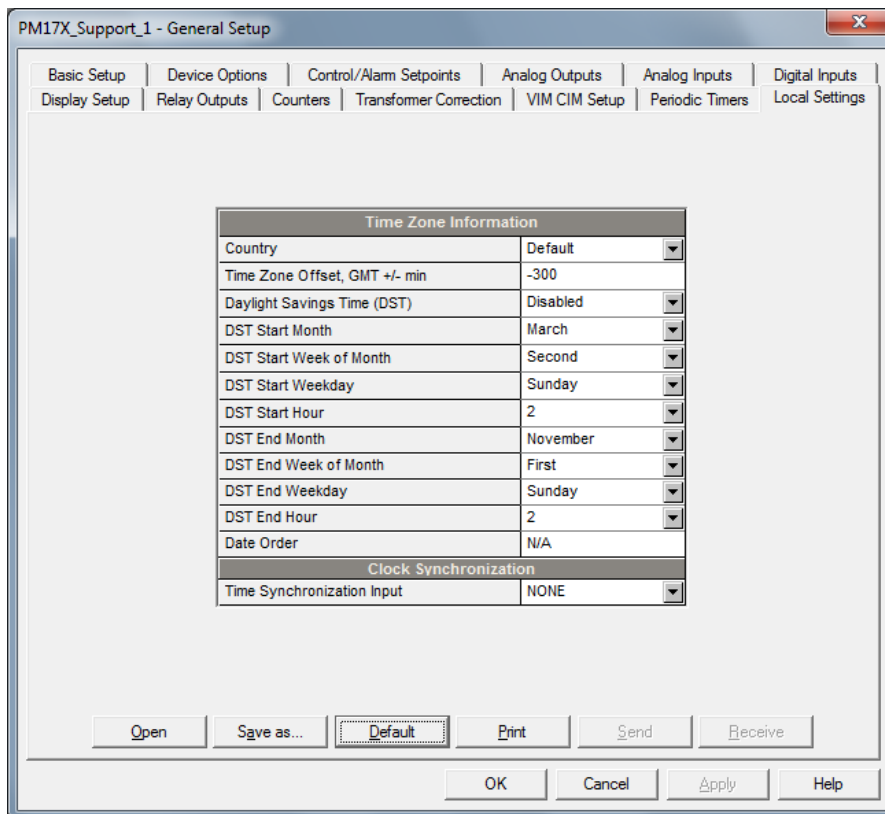

**Figure 10-20 Real Time Clock Dialog Box – Local Settings setup**

The available options are described in the following table:

Table 28: Time Zone setup options

Option	Format/Range	Default	Description
Time Zone Information			
Time zone offset, GMT +/- min	-720 to 720 min	-300 (Eastern Time)	Local offset in minutes from UTC (Universal Coordinated or Greenwich Mean Time). It is used to produce a local time from the GPS IRIG-B time code.
Daylight Savings Time (DST)	Disabled Enabled	Disabled	When DST is disabled, the RTC operates in standard time only. When enabled, the device automatically updates the time at 2:00 AM at the pre-defined DST switch dates.
DST start month DST start week DST start weekday DST Start Hour	Month-week-weekday-hour Month = Jan-Dec Week = 1 <sup>st</sup> , 2 <sup>nd</sup> , 3 <sup>rd</sup> , 4 <sup>th</sup> or Last (last week of the month) Day = Mon-Sun Hour = 1-6	March Second Sunday 2	The DST start date when Daylight Savings Time begins. The DST switch point is specified by the month, week of the month and weekday. By default, DST starts at 2:00 AM on the first Sunday in April of each year.
DST end month DST end week DST end weekday DST end Hour	Month-week-weekday-hour Month = Jan-Dec Week = 1 <sup>st</sup> , 2 <sup>nd</sup> , 3 <sup>rd</sup> , 4 <sup>th</sup> or Last (last week of the month) Day = Mon-Sun Hour = 1-6	November First Sunday 2	The DST end date when Daylight Savings Time ends. The DST switch point is specified by the month, week of the month and weekday. By default, DST ends at 2:00 AM on the last Sunday in November of each year.
Clock Synchronization			
Time synchronization input	GPS IRIG-B, SNTP, DI1-DI26(digital input 1-26)	-----	The external port receiving the time synchronization signal. If no external synchronization is used, set this option to IRIG-B: when a signal is not present, the PM17X PRO automatically uses internal RTC clock for time synchronization.

## Time Synchronization Source

The PM17X PRO receives the time synchronization signal either from a GPS clock having an IRIG-B time-code output, or from an IEEE 1588 PTPv2 master clock. If the IRIG-B option is selected but the IRIG-B signal is not present on the device input, the PM17X PRO automatically uses its internal RTC clock.

## Using the IRIG-B

To use the IRIG-B input, select the GPS IRIG-B option and connect the GPS master clock to the IRIG-B IRIG-B terminal.

The PMU230 IRIG-B port uses an unmodulated (pulse-width coded) timecode signal (unbalanced 5V level) according to the IRIG 200-04 standard.

When the IRIG-B signal is present on the device input, the PM17X PRO automatically synchronizes its clock with the GPS time each second, normally with accuracy better than 1 millisecond if the time is locked to the GPS satellite time. If the GPS clock loses the satellite signal, the clock continues to generate the IRIG-B time code referenced to the last available satellite time, but the time quality may get worse. Such signal losses can last from a few minutes to hours. During such outages the time code generated by the GPS receiver is typically accurate to within a few milliseconds over a 24-hour period.

You can check presence and quality of the IRIG-B signal through the RDM from the Clock Setup Menu, through HyperTerminal (see Testing the GPS Master Clock in Chapter 3) and via the Device Diagnostics. If the IRIG-B signal is lost, the PM17X PRO changes the time synchronization source to the internal RTC in 5 minutes. When the IRIG-B signal is restored, the device automatically acquires the GPS time.

If the IRIG-B signal is lost or time code quality changes (locked to the GPS satellite time or unlocked), the corresponding events are automatically recorded to the device Event log.

## IEEE 1588 PTP Time Synchronization

The PM17X PRO Ethernet port must be connected to an IEEE 1588 grandmaster clock through a 1588 PTPv2 peer-to-peer transparent clock switch compliant with IEEE Std 1588-2008.

Both PM17X PRO Ethernet ports can be connected to the same or two different 1588 switches. The device will obtain UTC time from one of the available sources and automatically switch to the other port whenever the signal is lost for any reason.

Each PM17X PRO port implements the ordinary PTPv2 clock, complying with the IEEE Std 1588-2008 standard, and uses the following PTP profile:

1. PTP version 2.
2. PTP transport over Layer 2 Ethernet (IEEE 802.3), IEEE 1588-2008, Annex F.
3. Multicast addressing.
4. Peer-to-peer (P2P) path delay measurement mechanism.
5. Capable of working with one-step and two-step master clocks.
6. Responds to peer path delay requests with two-step peer delay responses (Pdelay\_Resp, Pdelay\_Resp\_Follow\_Up messages).

## Using SNTP

Enable SNTP client operation and configure it if required (see [Setting-Up SNTP Client](#)).

When an SNTP server is not available or when a connection with a server is restored, the corresponding event is automatically recorded to the device Event log.

## Using External Minute Pulses

External time synchronization pulses are delivered through one of the PM17X PRO digital inputs. If the digital input is selected as the time synchronization source, the external pulse's edge adjusts the device clock at the nearest whole minute. The time accuracy is affected by the debounce time programmed for the digital input, and by the operation delay of the external relay.

## Chapter 11 Configuring Recorders

The PM17X PRO is equipped with a 16GBytes onboard non-volatile memory for data, event and waveform recording.

Before using recorders, the device memory must be partitioned between log files. The device memory is fully configurable; you can define how much memory to allocate for each log file. If you want to change the factory settings, follow the guidelines in the section below.

### 11.1 Configuring Device Memory

The PM17X PRO memory can be partitioned for a total of 28 log files:

- Event log
- 16 Data logs
- 8 Waveform logs
- PQ log

To view the device memory settings, select Memory/Log from the Meter Setup menu, and then click on the Log Memory tab.

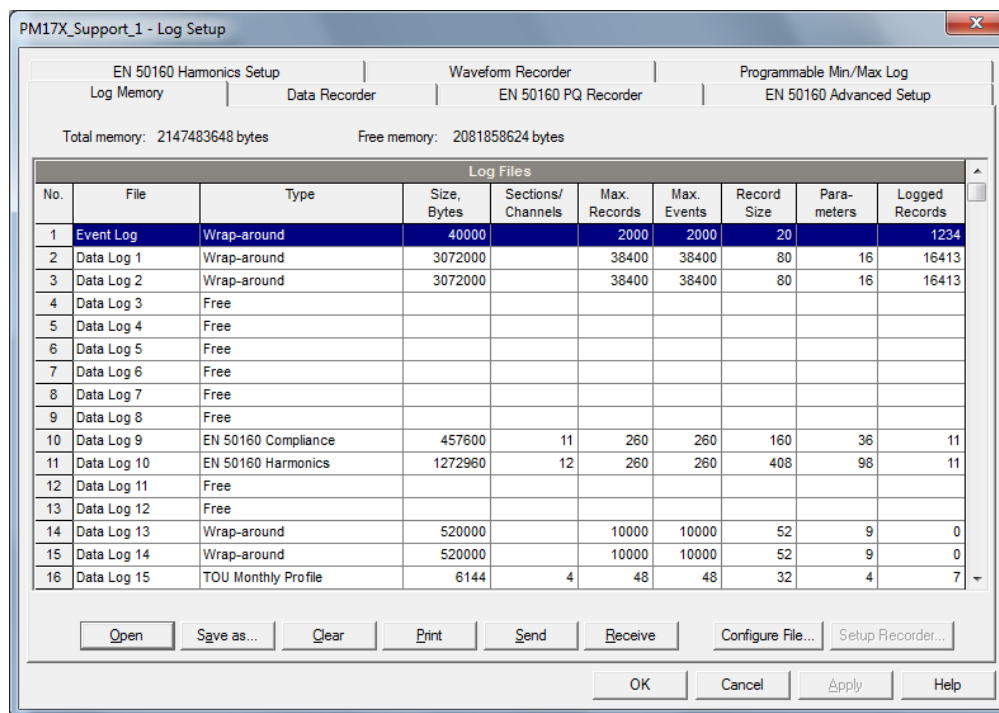

Figure 11-1 Memory Setup Dialog Box – Log Memory Setup

The following table shows available file options.

**Table 29: Log Files Setup options**

Option	Format/Range	Description
Type	Wrap around, Non-wrap TOU Monthly Profile TOU Daily Profile	Defines the file behavior when it is filled up. Wrap around: recording continues over the oldest records. Non-wrap: recording is stopped until the file is cleared. TOU Monthly Profile: monthly TOU profile data log (only for data log #15). Wrap around by default. TOU Daily Profile: daily TOU profile data log (only for data log #16). Wrap around by default.
Size		Shows the size of the memory allocated to the file. It is set automatically depending on the size of a file record and the number of records in the file.
Sections/Channels	0-32	Defines the numbers of sections in a multi-section TOU profile data log file or the number of recording channels in a waveform log file
Num. of Records	0-65535	Allocates the file memory for a predefined number of records
Record size		Shows the size of the file record for a single channel or section. It is set automatically depending on the file and on the number of parameters in the data record
Parameters		Defines the number of parameters in a single data record for data log files.

Memory is allocated for each file statically and does not change unless you re-organize the files. The PM17X PRO automatically performs de-fragmentation of the memory each time the file allocation changes. This helps keep all free memory in one continuous block, and thus prevents possible leakage of memory caused by fragmentation.

Data log files #15 and #16 may be configured to record TOU monthly profile and TOU daily profile data on a daily or monthly basis.

To change the file properties or to create a new file:

1. Double click on the file partition you want to change, or highlight the file row, and then click on the "Configure File" button.
2. To change the file properties, select desired parameters, and then click OK. For your reference, the record size and the number of records available for the file are reported in the dialog box.
3. To delete a file partition, click on Delete, and then click OK.
4. Send your new setup to the device.

The following table shows how to calculate a file size for different files.

Table 30

File	Record Size, Bytes	File Size, Bytes
Event Log	20	Record Size × Number of Records
Data Log	2 + 4 × Number of Parameters	Record Size × Number of Records
TOU Profile Log (Data log #15-#16)	12 + 4 × Number of Season Tariffs	Record Size × Number of TOU Registers × Number of Records × 2
Waveform Log	1072	Record Size × Number of Channels × Number of Series × Number of Records per Series
PQ Log	32	Record Size × Number of Records

For more information on configuring specific files, see following sections.

The device memory is pre-configured for regular data trending and fault recording applications as shown in the following table.

Table 31

No.	File	Type	Size,Bytes	Sections/ Channel	Max.of Records	Max.of Events	Description
1	Event log	Wrap around	40000		2000	2000	
2	Data log #1	Wrap around	3072000		38400	38400	Configured for continuous data recording
3	Data log #2	Wrap around	3072000		38400	38400	Configured for continuous data recording
10	Data log #3	free					
...	....	....	....	....	....	....	....
14	Data log #13	free					
15	Data log #14 (PQ data trend)	Wrap around	520000		10000	10000	Used by the PQ recorder
24	Waveform log #7	Wrap around	42880000	10	4000	1000	Used by the PQ recorder
25	Waveform log #8	Wrap around	17152000	8	2000	500	Used by the PQ recorder
27	PQ log	Wrap around	640000		20000	20000	

## 11.2 Configuring the Event Recorder

To change the Event log file size:

1. Select Memory/Log from the Meter Setup menu, and then click on the Log Memory tab.
2. Double click on the Event log file partition with the left mouse button.

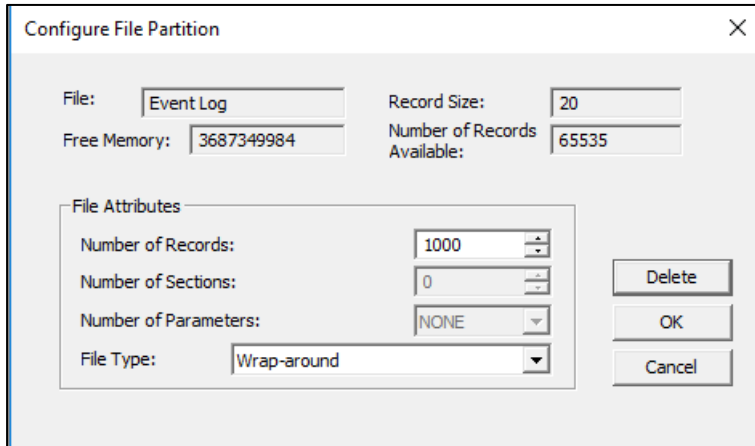

Figure 11-2 Memory/Log Setup Dialog Box – Event Log configure file partition

3. Select a file type.
4. Select the maximum number of records you want to be recorded in the file.
5. Click OK, and then send your new setup to the device or save to the device database.

By default, the Event recorder stores all events related to configuration changes, reset, and device diagnostics. In addition, it records events related to setpoints operations. Each setpoints should be individually enabled for recording to the Event log.

To log setpoints operations, add the “Event log” action to the setpoints actions list. Put the event log action at the beginning of the list to allow other recorders to use the sequence number assigned to the event for cross-linking between records logged to different files. When a setpoints event happens, the Event recorder logs all setpoints conditions that caused the event and all setpoints actions performed in response to the event.

## 11.3 Configuring the Data Recorder

The Data recorder is programmable to record up to 16 data parameters per record in each of 14 data log files (TOU Monthly Profile & TOU Daily Profile data log files may include up to 9 parameters). The list of parameters to be recorded to a data log is configured individually for each file.

### 11.3.1 Conventional Data Log Files

To create a new data log file or re-configure an existing file:

1. Select Memory/Log from the Meter Setup menu, and then click on the Log Memory tab.
2. Double click on the file partition with the left mouse button.
3. Select a file type.
4. Select the number of parameters to be recorded in the file records.
5. Select the maximum number of records to be recorded in the file.
6. Click OK, and then send your new setup to the device, or save to the device database.

Figure 11-3 Memory/Log Setup Dialog Box – Data Log 1 configure file partition

7. Highlight the data log file row with the left mouse button, and then click on the “Setup Recorder” button, or click on the “Data Recorder” tab and select the log number corresponding to your file.

No.	Group	Parameter	No.	Group	Parameter
1	RT PHASE	V1	9	RT TOTAL	kVA
2	RT PHASE	V2	10	RT TOTAL	PF
3	RT PHASE	V3	11	RT PHASE	V1 THD
4	RT PHASE	I1	12	RT PHASE	V2 THD
5	RT PHASE	I2	13	RT PHASE	V3 THD
6	RT PHASE	I3	14	RT PHASE	I1 THD
7	RT TOTAL	kW	15	RT PHASE	I2 THD
8	RT TOTAL	kvar	16	RT PHASE	I3 THD

Figure 11-4 Memory/Log Setup Dialog Box – Data Log 1 setup recorder

8. Configure the list of parameters to be recorded in the data log file. You are not allowed to select more parameters than you defined when configuring your file. Refer to chapters 17/18 for a list of available parameters.

For your convenience, PAS follows your selection and helps you to configure a series of the neighboring parameters: when you open the “Group” box for the next parameter, PAS highlights the same group as in your previous selection; if you select this group again, PAS automatically updates the “Parameter” box with the following parameter in the group.

9. Add the name for your data log file in the “Name” box. It will appear in the data log reports.
10. Save your new setup to the device database, and send it to the device.

### 11.3.2 Factory Preset Periodic Data Logs

Data logs #1 and #2 are factory preset for periodic recording of the standard power quantities as shown in the following table.

**Table 32**

No.	Parameter	No.	Parameter
Data Log #1			
	RT (1-cycle) V1		RT (1-cycle) Total kVA
	RT (1-cycle) V2		RT (1-cycle) Total PF
	RT (1-cycle) V3		RT (1-cycle) V1 THD
	RT (1-cycle) I1		RT (1-cycle) V2 THD
	RT (1-cycle) I2		RT (1-cycle) V3 THD
	RT (1-cycle) I3		RT (1-cycle) I1 THD
	RT (1-cycle) Total kW		RT (1-cycle) I2 THD
	RT (1-cycle) Total kvar		RT (1-cycle) I3 THD
Data Log #2			
	kW Import Sliding Demand		I1 Demand
	kvar Import Sliding Demand		I2 Demand
	KVA Sliding Demand		I3 Demand
	kWh Import		V1 Demand
	kWh Export		V2 Demand
	kvarh Import		V3 Demand
	kvarh Export		RT (1-cycle) I4
	kVAh		RT (1-cycle) V4

Setpoints #1 is preset at the factory to trigger Data logs #1 and #2 in 15 min intervals.

### 11.3.3 Factory Preset PQ Data Log

Data log #14 is factory preset for RMS trending on the power quality events and is intended for the use with the PQ recorders. The default PQ data log configuration is shown in the following table.

**Table 33**

No.	Parameter	No.	Parameter
Data Log #14 (PQ data trend)			
1	Generic V1		
2	Generic V2		
3	Generic V3		
4	Generic I1		
5	Generic I2		
6	Generic I3		
7	Generic FREQ		
8			

The generic data group represents generic volts, amps, etc., regardless of the data integration time. The PQ recorder can use different time envelopes to record data integrated over intervals from a half cycle to 10 minutes depending on the duration of the power quality event.

### 11.3.4 TOU Profile Data Log Files

Data log files #15 and #16 are configurable to store the TOU monthly profile log and the TOU daily profile log respectively.

A TOU profile log file is organized as a multi-section file that has a separate section for each TOU energy and maximum demand register. The number of sections is taken automatically from the Summary/TOU Registers setup (see [Configuring Summary and Bill./TOU Reg.](#) in Chapter 12). Since each TOU energy register has a shadow maximum demand register, the number of sections in the file is twice the number of the allocated TOU registers.

In order to correctly allocate the memory space for TOU profile log files, assign TOU registers before you set up your TOU profile log files.

To configure a TOU daily profile log file:

1. Configure your TOU registers and TOU schedule before allocating memory for a profile log file (see [Configuring Summary and Bill./TOU Reg.](#) in Chapter 12).
2. Select Memory/Log from the Meter Setup menu, and then click on the Log Memory tab.
3. Double click on the Data Log #15 or Data Log #16 partition row.

The screenshot shows a dialog box titled "Configure File Partition" with a close button (X) in the top right corner. The dialog is divided into several sections:

- File:** A text box containing "Data Log 16".
- Record Size:** A text box containing "32".
- Free Memory:** A text box containing "3684981984".
- Number of Records Available:** A text box containing "65535".
- File Attributes:** A group box containing:
  - Number of Records:** A spin box set to "14800".
  - Number of TOU Registers:** A spin box set to "9".
  - Number of Tariffs (+1 for Sum):** A dropdown menu set to "4".
  - File Type:** A dropdown menu set to "TOU Daily Profile".
- Buttons:** On the right side, there are three buttons: "Delete", "OK", and "Cancel".

Figure 11-5 Memory/Log Setup Dialog Box – Data Log 16 configure file partition

4. Select the TOU Monthly Profile or TOU Daily Profile in the File Type box.
5. Select the number of season tariffs in your TOU schedule.
6. Select the maximum number of records you want to be recorded in the file assuming that a new record is added once a month or once a day.
7. Click OK and send your setup to the device or save to the database.

## 11.4 Configuring the Waveform Recorder

Waveform log files are organized as multi-section files that store data for each recording channel in a separate section.

A regular waveform log file records up to 7 analog channels simultaneously: seven AC channels (three voltages and four currents), and up to 26 digital inputs DI1-DI16, DI17-DI32 and DI33-DI48 organized in three sections as three 16-bit analog channels.

A single channel waveform record contains 512 points of the sampled input signal. If a waveform log is configured to record more samples per event than a single record can hold, the waveform recorder stores as many records per event as required to record the entire event. All waveform records related to the event are merged in a series and have the same series number, so they can be plotted together.

The PM17X PRO supports 8 waveform files that can record waveforms at four programmable sampling rates: 32, 64, 128 or 256 samples per cycle.

To configure a waveform log file:

1. Select Memory/Log from the Meter Setup menu, and then click on the Log Memory tab.
2. Double click on a waveform log partition with the left mouse button.
3. Select a file type for your file.
4. Select the maximum number of records to be recorded in the file.

The number of records in the waveform log file needed to store one waveform event (series) is defined as follows:

Number of Records per Series = Sampling Rate (Samples per Cycle) x Number of Cycles per Event / 512

The total number of records you must allocate to store the required number of events (series) is defined as follows:

Number of Records = Number of Records per Series x Number of Series

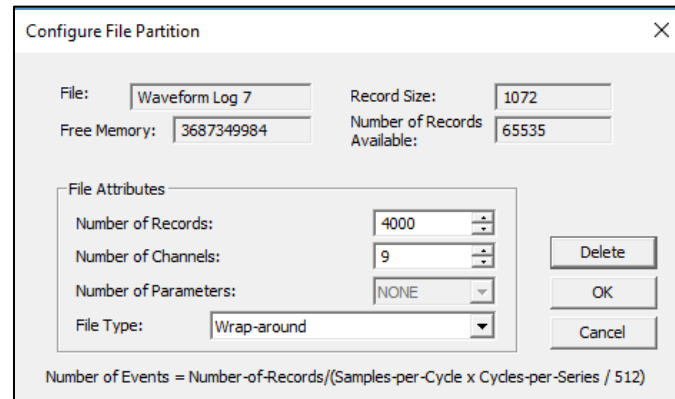

Figure 11-6 Memory/Log Setup Dialog Box – Waveform Log 7 configure file partition

For example, if you want to record a 64-cycle waveform sampled at a rate of 32 samples per cycle, the number of records required for one waveform series would be:

Number of Records per Series =  $(32 \times 64) / 512 = 4$ .

If you want to allocate space sufficient to store 20 waveform events (series), you should set up the waveform log file for  $4 \times 20 = 80$  records.

5. Click OK, and send your setup to the device or save to the database.
6. Click "Setup Recorder", or click on the "Waveform Recorder" tab.

The following table lists available waveform options.

Table 34

Option	Range	Description
Samples per Cycle	32, 64, 128, 256 samples/cycle	Defines the sampling rate for the waveform log
Cycles per Series	16-10848 (32 samples/cycle), 8-5424 (64 samples/cycle), 4-2712 (128 samples/cycle) 2-1356 (256 samples/cycle)	Defines the total duration of the waveform recording per event/series
Before Cycles	1-20	Defines the number of cycles to be recorded prior to the event
Num. of Channels	1-26	The number of the simultaneously recorded channels

7. Select the sampling rate for waveforms.
8. Select the number of cycles to be recorded prior to the event, and a total number of cycles in the waveform.
9. Add the name for your waveform log file in the "Name" box. It will appear in the waveform reports.

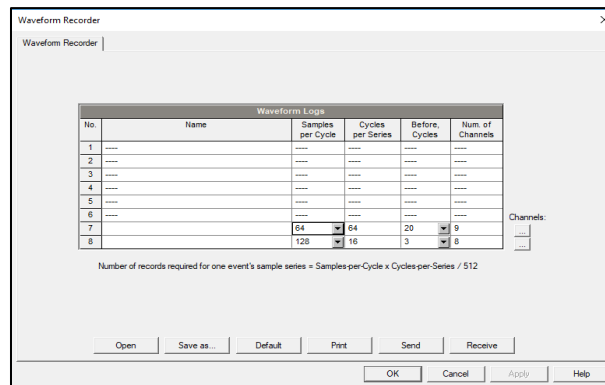

Figure 11-7 Memory/Log Setup Dialog Box – Waveform Log 7 setup recorder

10. To select the channels, click on the "Channels" button, check the boxes for channels to be recorded, and then click OK.

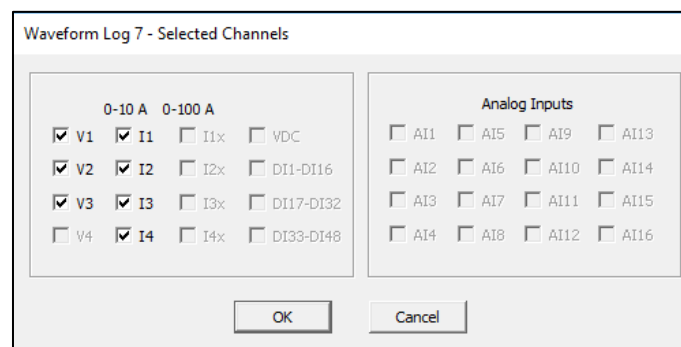

Figure 11-8 Memory/Log Setup Dialog Box – Waveform Log 7 selected channels

11. Save your waveform setup to the site database, and send it to the device.

The picture above shows the factory preset waveform logs. Waveform log #7 is used with the PQ events and PQ transient and short duration events. Waveform log #8 is used with the PQ recorder to store waveforms related to harmonics events.

## 11.5 Configuring IEEE1159 Power Quality Recorder

The Power Quality (PQ) recorder identifies the power quality events according to predefined parameters limits and records them to the log file with the precise start and end timestamps and a fault magnitude. Impulsive transients and short-duration voltage variations (sags and swells) can also be viewed as magnitude/duration pairs on the well-known ITIC curve chart for assessing the minimum equipment immunity.

The PQ recorder can trigger the waveform recorder to record the fault waveforms before, during and after the PQ event for detailed event analysis. It may be useful for troubleshooting problems throughout electrical networks, for example, to identify and locate the source of a power quality event and to select an appropriate solution.

### PQ Events Evaluation

The events are classified in accordance with the IEEE 1159 power quality categories. The table below shows the categories recorded by the device, the metering data used to detect voltage and frequency faults, their typical triggering thresholds and event durations.

#### Impulsive transients

Impulsive transients are detected as impulses with a rise time less than 0.5 ms and duration from 80 us to  $\frac{1}{2}$  cycle. The impulse magnitude is measured as the overshoot voltage magnitude above the normal voltage wave shape. It is referenced to the nominal peak voltage ( $1.414 U_n$ ).

#### Sags and swells

A voltage sag or swell is classified as one polyphase event regardless of the shape and of the number of phases affected (as per IEC 61000-4-30). An event can begin on one phase and end on another phase. The fault magnitude is recorded separately for each phase involved. The event duration is measured from the instant at which the voltage falls/rises below/above the start threshold on one of the phases to that at which it becomes greater/lower than the end threshold on all affected phases including a threshold hysteresis.

#### Voltage Interruptions

The voltage interruption is detected when the voltages on all phases fall below the interruption threshold (as per IEC 61000-4-30).

Table 35

Event ID	PQ category	Trigger parameter	Reference value	Typical thresholds, %	Event duration
PQE11	Impulsive transients	Instantaneous overshoot voltage	$U_n$ peak voltage	20-200%	80 us–10 ms
PQE211	Instantaneous sag	$\frac{1}{2}$ cycle RMS voltage	$U_n$ RMS	80-90%	< 30 cycles
PQE212	Instantaneous swell	$\frac{1}{2}$ cycle RMS voltage	$U_n$ RMS	110-120%	< 30 cycles
PQE221	Momentary interruption	$\frac{1}{2}$ cycle RMS voltage	$U_n$ RMS	0-10%	< 3 sec
PQE222	Momentary sag	$\frac{1}{2}$ cycle RMS voltage	$U_n$ RMS	80-90%	< 3 sec
PQE223	Momentary swell	$\frac{1}{2}$ cycle RMS voltage	$U_n$ RMS	110-120%	< 3 sec
PQE231	Temporary interruption	$\frac{1}{2}$ cycle RMS voltage	$U_n$ RMS	0-10%	< 1 min
PQE232	Temporary sag	$\frac{1}{2}$ cycle RMS voltage	$U_n$ RMS	80-90%	< 1 min
PQE233	Temporary swell	$\frac{1}{2}$ cycle RMS voltage	$U_n$ RMS	110-120%	< 1 min
PQE31	Sustained interruption	$\frac{1}{2}$ cycle RMS voltage	$U_n$ RMS	0-10%	> 1 min
PQE32	Undervoltage	$\frac{1}{2}$ cycle RMS voltage	$U_n$ RMS	80-90%	> 1 min
PQE33	Overvoltage	$\frac{1}{2}$ cycle RMS voltage	$U_n$ RMS	110-120%	> 1 min
PQE4	Voltage unbalance	3-sec negative sequence unbalance	No	1-5%	Steady state

Event ID	PQ category	Trigger parameter	Reference value	Typical thresholds, %	Event duration
PQE52	Harmonics THD	3-sec harmonic THD	No	5-20%	Steady state
PQE53	Interharmonics THD	3-sec interharmonic THD	No	2-8%	Steady state
PQE6	Voltage fluctuations (flicker)	10-min Pst	No	1-5	Steady state
PQE7	Frequency variations	3-sec frequency	Nominal frequency	1-6%	Steady state

Un – nominal device voltage

## PQ Recorder Setup

The PQ recorder setup allows you to adjust thresholds and hysteresis for PQ triggers, to define the waveform and data log options for PQ events, and to enable or disable the PQ recorder in your device.

To configure the PQ recorder:

1. Select Memory/Log from the Meter Setup menu, and then click on the PQ Recorder tab.
2. If you want to change the default settings, adjust thresholds and hysteresis for PQ triggers.
3. Select the waveform and data logging options for PQ events.
4. Download your setup to the device.

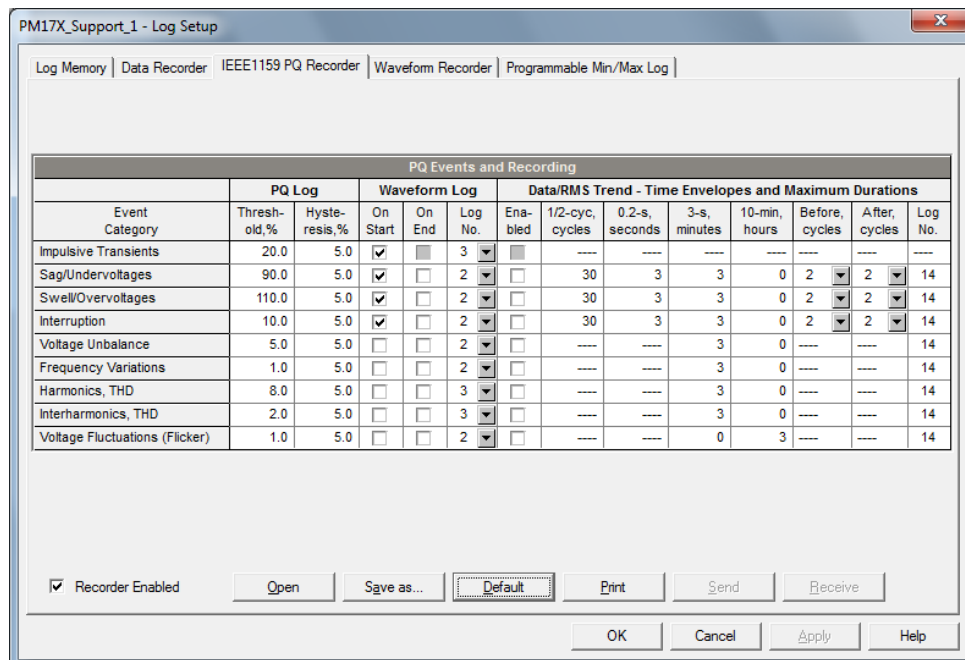

Figure 11-9 Memory/Log Setup Dialog Box – PQ recorder setup

The available PQ recorder options are shown in the following table:

Table 36

Option	Range	Default	Description
Thresholds			
Threshold, %	0-200.0%		Defines the operating threshold for the PQ trigger in percent of the nominal (reference) value

Option	Range	Default	Description
Hysteresis, %	0-50.0%	5.0	Defines the hysteresis for PQ trigger in percent of the threshold
Waveform Log			
On Start	Checked Unchecked	Checked	Enables waveform log when the PQ event starts
On End	Checked Unchecked	Unchecked	Enables waveform log when the PQ event ends
Log No.	1-8	7	Specifies the waveform log file used for waveform recording on the PQ event
Data/RMS Plot			
Enabled	Checked Unchecked	Unchecked	Enables concurrent RMS trace plot to the data log file while the PQ event continues
1/2-cyc	0-10,000 cycles	30	Duration of the 1/2-cycle data trace
0.2-sec	0-10,000 seconds	3	Duration of the 0.2-second data trace
3-sec	0-10,000 minutes	3	Duration of the 3-second data trace
10-min	0-10,000 hours	0	Duration of the 10-minute data trace
Before, Cycles	0-20 cycles	2	The number of cycles to be recorded prior to the event
After, Cycles	0-20 cycles	2	The number of cycles to be recorded after the event
Log No.	14		Specifies the data log file used for data recording on the PQ event

The Sag, Swell and Interruption triggers use the same waveform and data log options. If you change one of them, the others are automatically adjusted to the same setting.

The waveform log option allows recording waveforms both at the start and the end of a PQ event. Since the voltage variations may last from some seconds to minutes, this allows capturing and analyzing the voltage transitions using short time waveform recording at the start and the end of the voltage sag or swell.

The data log option allows concurrent recording of the RMS data at a variable rate depending on the PQ event duration. To reduce the memory consumption for recording long duration events, the PQ recorder uses different time envelopes (aggregation intervals) for data tracing and changes the recording rate accordingly. You can specify for each PQ trigger how much time to record data using one or more-time envelopes.

To enable or disable the PQ recorder:

1. Check or uncheck the "Recorder Enabled" checkbox.
2. Send your setting to the device.

## Power Quality Event Indication and Cross Triggering

When the PQ recorder detects a power quality fault, it generates the specific internal event PQ EVENT that can be monitored through a control setpoints to give a fault indication via relay contacts. The event can be found under the STATIC EVENTS group in the setpoints trigger list.

The power quality fault signal is used for cross triggering multiple recorders through a dedicated digital input in order to simultaneously record disturbances at different locations. External triggering of the Waveform and Data recorders for recording disturbance data can be done through a setpoints programmed to monitor the status of a digital input. For more information on cross triggering, see Fault Indication and Cross Triggering.

## 11.6 Fast Transient Recorder

The fast transient recorder is provided with the TRM/PMU add-on module. It can detect impulsive and low frequency oscillatory transient overvoltages with peaks up to 2kV and durations from 10 microseconds.

The recorder does not require any special setup above a conventional PQ recorder setup for transient overvoltages. Waveform log #6 is especially dedicated for fast transient waveforms, it can be used only by Power Quality Recorder when fast transient event happens. It automatically stores 4-cycle voltage and current waveforms sampled at a rate of 2048 samples/cycle or 8-cycle voltage and current waveforms sampled at a rate of 1024 samples/cycle whenever a transient overvoltage is detected.

Required sampling rate of Waveform log #6 should be defined in Waveform Recorder.

Unlike a basic transient recorder provided with the PM17X PRO that detects and records transient voltages between phase conductors and a neutral terminal (in 4LN3 and 3LN3 configurations), or between two phase conductors (in line-to-line configurations), the fast transient recorder detects transient voltages between phase conductors and a ground terminal and between the neutral and a ground terminal regardless of a wiring configuration.

See the PM17X PRO installation for the terminal location and wiring diagrams. To help you check your voltage connections, the PM17X PRO provides RMS voltages V1x through V3x, neutral voltage V4x relative to the ground terminal, phase RMS currents I1x through I3x and neutral current I4x that you can monitor via PAS.

## Chapter 12 Totalization Energy & TOU Registers

The PM17X PRO provides 16 summary energy registers and 16 parallel TOU energy and maximum demand registers to link to any internal energy source or to any external pulse source that delivers energy pulses through the device digital inputs.

A total of 64 energy sources can be connected to the summary and TOU registers. Each summary register can accumulate energies from multiple sources using arithmetic addition and subtraction. A summary register may be linked to another summary register to provide more comprehensive energy calculations.

The TOU system provides for each TOU energy register a parallel maximum demand register that is updated automatically when a corresponding TOU register is activated. The device supports 16 different tariffs using an arbitrary tariff structure.

The PM17X PRO TOU system technique is based on the currently active TOU annual calendar that assigns the user-selectable daily profile to each day of the year. The TOU daily profiles specify daily tariff change points. The PM17X PRO memory stores calendars for 10 years. A total of 16 types of days are supported with up to eight tariff changes per day.

By default, the summary registers in your device are not linked to energy sources and are not operational. To activate a summary energy register, link it to the energy source(s).

To activate TOU system:

1. Configure the TOU daily profiles for different types of days.
2. Configure the TOU calendars.
3. Link the TOU registers to the corresponding summary energy registers that are used as source registers for TOU system.

### 12.1 Configuring Summary and Bill./TOU Reg.

To configure the device summary and Billing/TOU registers, select Energy/TOU from the Meter Setup menu.

Billing/TOU Registers						Register Source List			
Reg.	TOU	Use Profile	Dmd Profile	Sum Profile	Units	No.	Source Input	Multiplier	Target
1	<input checked="" type="checkbox"/>	<input checked="" type="checkbox"/>	<input checked="" type="checkbox"/>	<input checked="" type="checkbox"/>	kWh	1	kWh IMPORT	1.000	Reg #1
2	<input checked="" type="checkbox"/>	<input checked="" type="checkbox"/>	<input checked="" type="checkbox"/>	<input checked="" type="checkbox"/>	kvarh	2	kvarh IMPORT	1.000	Reg #2
3	<input checked="" type="checkbox"/>	<input checked="" type="checkbox"/>	<input checked="" type="checkbox"/>	<input checked="" type="checkbox"/>	kWh	3	kWh EXPORT	1.000	Reg #3
4	<input checked="" type="checkbox"/>	<input checked="" type="checkbox"/>	<input checked="" type="checkbox"/>	<input checked="" type="checkbox"/>	kvarh	4	kvarh EXPORT	1.000	Reg #4
5	<input type="checkbox"/>	<input type="checkbox"/>	<input type="checkbox"/>	<input type="checkbox"/>	----	5	----	----	----
6	<input type="checkbox"/>	<input type="checkbox"/>	<input type="checkbox"/>	<input type="checkbox"/>	----	6	----	----	----
7	<input type="checkbox"/>	<input type="checkbox"/>	<input type="checkbox"/>	<input type="checkbox"/>	----	7	----	----	----
8	<input type="checkbox"/>	<input type="checkbox"/>	<input type="checkbox"/>	<input type="checkbox"/>	----	8	----	----	----
9	<input type="checkbox"/>	<input type="checkbox"/>	<input type="checkbox"/>	<input type="checkbox"/>	----	9	----	----	----
10	<input type="checkbox"/>	<input type="checkbox"/>	<input type="checkbox"/>	<input type="checkbox"/>	----	10	----	----	----
11	<input type="checkbox"/>	<input type="checkbox"/>	<input type="checkbox"/>	<input type="checkbox"/>	----	11	----	----	----
12	<input type="checkbox"/>	<input type="checkbox"/>	<input type="checkbox"/>	<input type="checkbox"/>	----	12	----	----	----
13	<input type="checkbox"/>	<input type="checkbox"/>	<input type="checkbox"/>	<input type="checkbox"/>	----	13	----	----	----
14	<input type="checkbox"/>	<input type="checkbox"/>	<input type="checkbox"/>	<input type="checkbox"/>	----	14	----	----	----
15	<input type="checkbox"/>	<input type="checkbox"/>	<input type="checkbox"/>	<input type="checkbox"/>	----	15	----	----	----
16	<input type="checkbox"/>	<input type="checkbox"/>	<input type="checkbox"/>	<input type="checkbox"/>	----	16	----	----	----

Figure 12-1 Energy/TOU Setup Dialog Box – Billing/TOU Registers setup

The available options are described in the following table:

**Table 37**

Parameter	Options	Default	Description
Billing/TOU Registers			
TOU	Unchecked Checked	Unchecked	Links multi-tariff registers to the selected energy source
Use Profile	Unchecked Checked	Unchecked	Enables recording energy registers in monthly/daily billing profile files (both total and tariff registers if TOU is enabled).
Dmd Profile	Unchecked Checked	Unchecked	Enables recording maximum demand registers in monthly/daily billing profile files (both total and tariff registers if TOU is enabled)
Sum Profile	Unchecked Checked	Unchecked	Enables recording total (summary) registers in monthly/daily billing profile files.
Units	None kWh kvarh kVAh m3 CF CCF	None	The energy register measurement unit.
Register Source List			

Parameter	Options	Default	Description
Source Input	None kWh IMPORT KWh EXPORT kvarh IMPORT kvarh EXPORT kvarh Q1 kvarh Q2 kvarh Q3 kvarh Q4 kVAh TOTAL kVAh IMPORT kVAh EXPORT L1 kWh IMPORT L2 kWh IMPORT L3 kWh IMPORT L1 kWh EXPORT L2 kWh EXPORT L3 kWh EXPORT L1 kvarh IMPORT L2 kvarh IMPORT L3 kvarh IMPORT L1 kvarh EXPORT L2 kvarh EXPORT L3 kvarh EXPORT L1 kVAh TOTAL L2 kVAh TOTAL L3 kVAh TOTAL DI1-DI26 SUMM REG #1 - 16	None	Links an internal or external energy source to the billing register.
Multiplier	0.001 to 100.000	1.000	The multiplication factor for the energy source.
Target	Reg#1- Reg#10	None	Defines the target summary register for the energy source.

## 12.2 Configuring TOU Daily Profiles

The PM17X PRO TOU calendar provides a season tariff schedule and an option for scheduled daylight savings switch dates.

To configure the TOU daily profiles, select Energy/TOU from the Meter Setup menu, and then click on the TOU Daily Profiles tab.

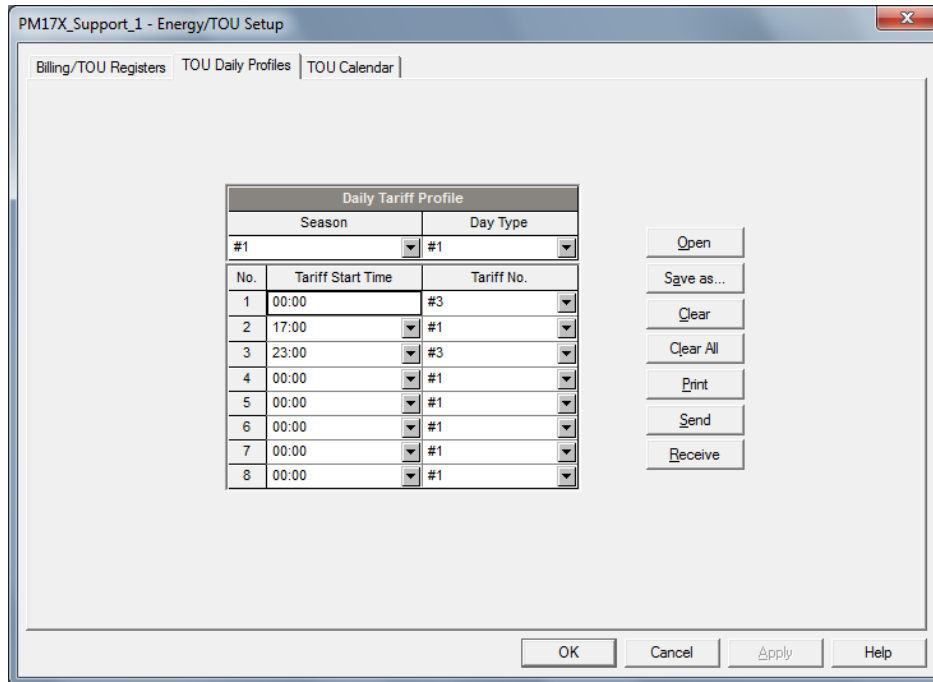

Figure 12-2 Energy/TOU Setup Dialog Box – TOU Daily Profiles setup

The profile setup allows you to specify the daily tariff change points with a 15-minute resolution.

To configure your daily profiles:

1. Select the desired season and day type
2. Select the start time for each tariff change point and the corresponding active tariff number.
3. Repeat the setup for all seasons and types of day.

The first tariff change point is fixed at 00:00 hours, and the last tariff change you specified will be in use until 00:00 hours on the next day.

**Note:** The billing monthly and daily profile files, and your billing data display are automatically configured for the number of active tariffs you defined in the meter TOU daily profile

## 12.3 Configuring TOU Calendar

The PM17X PRO TOU calendar provides a season tariff schedule and an option for scheduled daylight savings switch dates.

To configure your season tariff schedule, select Energy/TOU from the Meter Setup menu, and then click on the TOU Calendar tab.

No.	Season/Period	Day Type	Week of Month	Weekday	Till Weekday	Month	Day	Till Month	Till Day	Year
1	#1	#1	---	Sunday	Thursday	June	---	September	---	---
2	#1	#2	---	Friday	---	June	---	September	---	---
3	#1	#3	---	Saturday	---	June	---	September	---	---
4	#2	#1	---	Sunday	Thursday	December	---	February	---	---
5	#2	#2	---	Friday	---	December	---	February	---	---
6	#2	#3	---	Saturday	---	December	---	February	---	---
7	#3	#1	---	Sunday	Thursday	March	---	May	---	---
8	#3	#2	---	Friday	---	March	---	May	---	---
9	#3	#3	---	Saturday	---	March	---	May	---	---
10	#3	#1	---	Sunday	Thursday	October	---	November	---	---
11	#3	#2	---	Friday	---	October	---	November	---	---
12	#3	#3	---	Saturday	---	October	---	November	---	---
13	---	---	---	---	---	---	---	---	---	---
14	---	---	---	---	---	---	---	---	---	---
15	---	---	---	---	---	---	---	---	---	---
16	---	---	---	---	---	---	---	---	---	---

Figure 12-3 Energy/TOU Setup Dialog Box – TOU Calendar setup

The meter TOU calendar allows you to configure any tariff schedule based on any possible utility regulation. The calendar provides 48 entries that allow you to specify profiles for working days and holidays through all seasons in any order that is convenient for you, based on simple intuitive rules. There are no limitations on how to define your schedule. The meter is able to automatically recognize your settings and to select a proper daily tariff schedule for any day within a year.

To configure your season tariff schedule:

1. In the “Season/Period” box, select the season, and in the “Day Type” box, select a day type for this calendar entry.
2. Select the time interval when this daily tariff schedule is effective, based on the start and the end weekdays and, for a multi-season schedule, on the start and the end month for the selected season. It does not matter which order of weekdays or months you select: the meter recognizes the correct order.
3. For exception days like designated holidays, select a specific day either by specifying a day and month, or by selecting a month, a week and a weekday within the month.

**NOTE:** The PM17X PRO TOU calendar provides an embedded schedule of Hebrew holidays till 2039 for Israeli customers. To enable the automatic holiday schedule, select Israel in the Country box in the Local Settings setup (see Local Settings)

To configure your DST schedule:

1. Select DST in the “Season/Period” box.
2. Select the DST start month and day in the “Month” and “Day” boxes.
3. Select the DST end month and day in the “Till Month” and “Till Day” boxes.
4. In the “Year” box, select a year for which these dates will be effective.
5. Repeat steps 2-4 for all years for which you wish to provide a DST schedule.

To make your DST schedule effective:

1. Go to the Local Settings setup (see Local Settings).
2. Select “Scheduled” in the Daylight Saving Time (DST) box.
3. Send your new setting to the meter.
4. This section describes how to customize protocol options for use with your application software.

# Chapter 13 Configure Communication Protocols

## 13.1 Configuring Modbus

### 13.1.1 Modbus Point Mapping

The PM17X PRO provides 120 user assignable registers at addresses 0 to 119. You can re-map any register available in the meter to any assignable register so that registers found at different locations may be accessed with a single request by re-mapping them to adjacent addresses.

Initially these registers are reserved and none of them points to an actual data register. To build your Modbus register map:

1. Select Protocol Setup from the Meter Setup menu, and click on the Modbus Registers tab.
2. Click on the Default button to cause the assignable registers to reference the actual default meter register 6656 (0 through 119 are not allowable register addresses for re-mapping).

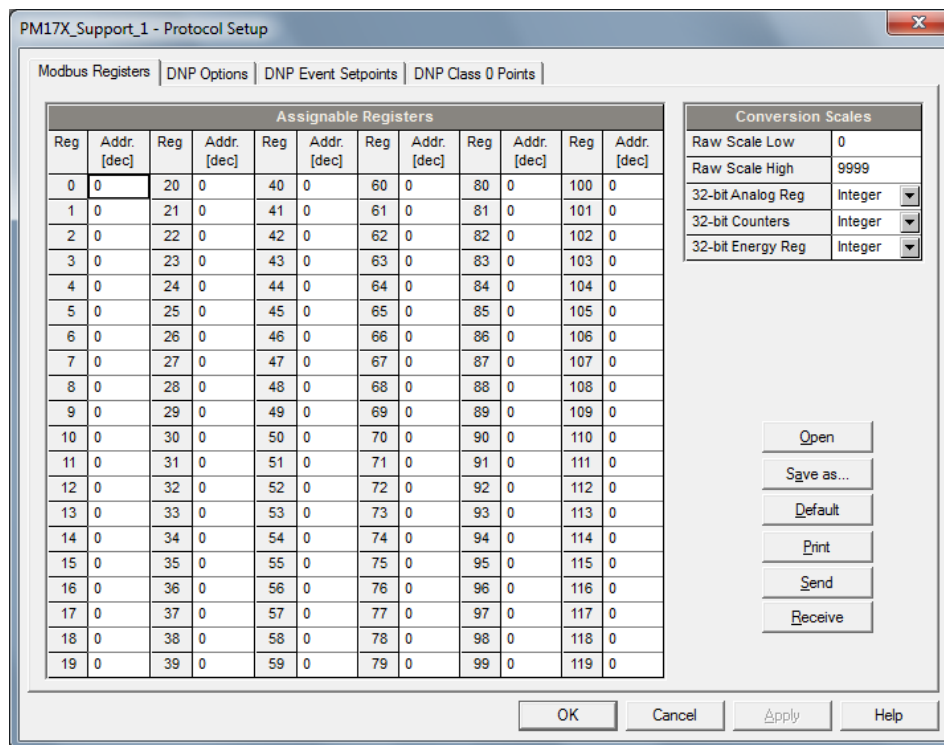

**Figure 13-1 Protocol Setup Dialog Box – Modbus Registers Tab**

3. Type in the actual addresses you want to read from or write to via the assignable registers. Refer to the PM17X PRO Modbus Reference Guide for a list of the available registers. Note that 32-bit Modbus registers should always start at an even register address.
4. Click Send to download your setup to the meter.

### 13.1.2 Changing 32-bit Register Format

The PM17X PRO allows you to read 32-bit Modbus analog registers, energy counters and binary counters either in integer format, or in IEEE single precision floating point format.

The 32-bit Modbus registers are factory-set to integer format. To change the register format:

1. Select Protocol Setup from the Meter Setup menu, and click on the Modbus Registers tab.
2. Change the 32-bit register format in the Modbus Options pane.
3. Click Send to download your setup to the meter.

### 13.1.3 Setting Modbus com port as master/client

The PM17X PRO COM port is working in Modbus master or client mode (client mode is the default)

The PM17X PRO can serve as transparent gateway when configured to be master. It enables exchanging messages between serial connected devices and eXpertPower or Scada via PM17X PRO Ethernet connection.

The PM17X PRO is forwarding all client messages to target devices and then return response to the master application

Setting the working mode might be done through PAS or using the front menu

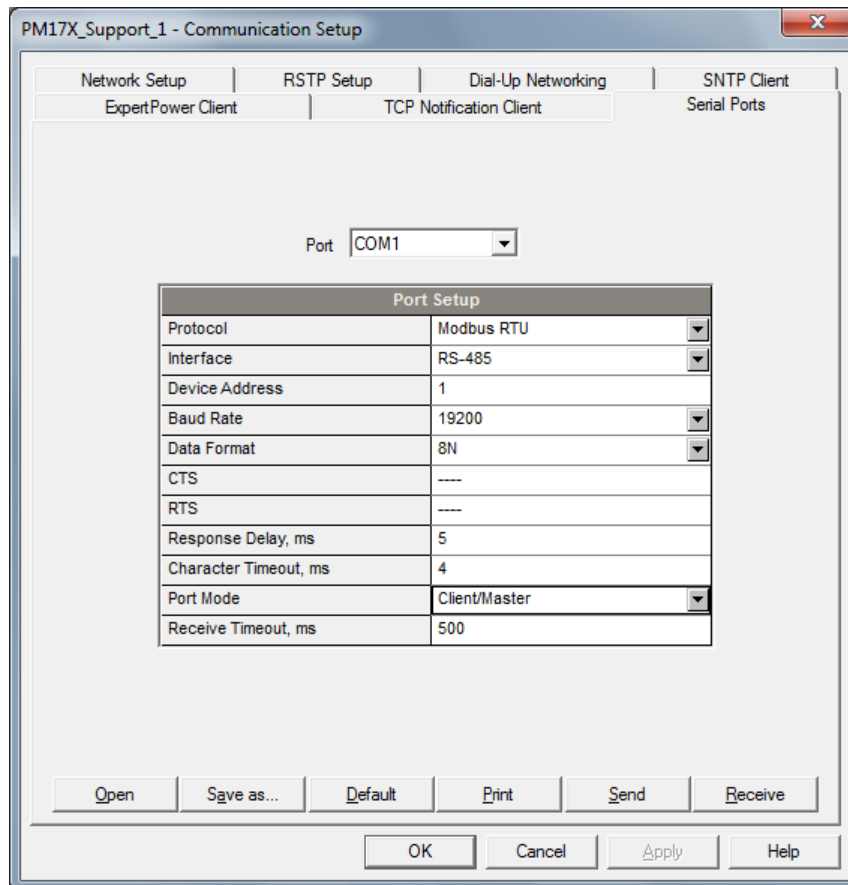

Figure 13-2 Serial port Setup Dialog Box – Modbus port mode

## 13.2 Configuring DNP3

Refer to the PM17X PRO DNP3 Reference guide for information on the DNP3 protocol implementation and a list of the available data points.

### 13.2.1 DNP Options

Select Protocol Setup from the Meter Setup menu and click on the DNP Options tab.

The screenshot shows the 'PM17X\_Support\_1 - Protocol Setup' dialog box with the 'DNP Options' tab selected. The dialog is divided into several sections:

- Binary Inputs (BI):**
  - Number of BI to generate events: 21
  - Default Binary Input Object: 1-bit Packed
  - Binary Input Change Event Object: With Time
- Analog Inputs (AI):**
  - Number of AI to generate events: 43
  - Default Analog Input Object: 16-bit
  - Analog Input Change Event Object: 16-bit +Time
  - Default Frozen Analog Input Object: ----
  - Frozen Analog Change Event Object: ----
- Binary Counters (BC):**
  - Number of BC to generate events: 0
  - Default Binary Counter Object: 32-bit
  - Binary Counter Change Event Object: 32-bit +Time
  - Default Frozen Binary Counter Object: 32-bit
  - Frozen Counter Change Event Object: ----
- DNP General Options:**
  - 16-bit AI Scaling: Enabled
  - 16-bit BC Scaling: x1
  - Re-mapping Event Points: Disabled
  - SBO Timeout, s: 10
  - Time Sync Period, s: 86400
  - Multi Fragment Interval, ms: 50
  - Location: Station
  - Max. Directory Entries: 20
  - TCP Port Number: 20000

At the bottom of the dialog, there are buttons for 'Open', 'Save as...', 'Default', 'Print', 'Send', 'Receive', 'OK', 'Cancel', 'Apply', and 'Help'.

**Figure 13-3 Protocol Setup Dialog Box – DNP Options Tab**

The following table describes available options. Refer to the DNP3 Data Object Library document available from the DNP User's Group on the DNP3 object types.

Table 38: DNP Options

Parameter	Options	Default	Description
Binary Inputs (BI)			
Binary Input Object	Single-bit With Status	Single-bit	The default BI object variation for requests with qualifier code 06 when no specific variation is requested
Analog Inputs (AI)			
Analog Input Object	32-bit 32-bit-Flag 16-bit 16-bit-Flag	16-bit-Flag	The default AI object variation for requests with qualifier code 06 when no specific variation is requested
Binary Counters (BC)			
Binary Counter Object	32-bit+Flag 32-bit-Flag 16-bit+Flag 16-bit-Flag	32-bit-Flag	The default BC object variation for requests with qualifier code 06 when no specific variation is requested
DNP General Options			
16-bit AI Scaling	Disabled Enabled	Enabled	Allows scaling 16-bit analog input objects (see description below)
16-bit BC Scaling	x1,x10, x100, x1000	x1	Allows scaling 16-bit binary counter objects (see description below)
SBO Timeout <sup>3</sup>	2-30 sec	10	Defines the Select Before Operate (SBO) timeout when using the Control-Relay-Output-Block object
Time Sync Period <sup>4</sup>	0-86400 sec	86400	Defines the time interval between periodic time synchronization requests
Multi Fragment Interval	50-500 ms	50	Defines the time interval between fragments of the response message when it is fragmented

### Scaling 16-bit AI objects

Scaling 16-bit AI objects allows accommodating native 32-bit analog input readings to 16-bit object format; otherwise, it may cause an over-range error if the full-range value exceeds a 16-bit point limit.

Scaling is enabled by default. It is not related to points that are read using 32-bit AI objects.

Refer to the PM17X PRO DNP3 Reference Guide for information on the data point scales and a reverse conversion that should be applied to the received scaled values.

### Scaling 16-bit Binary Counters

Scaling 16-bit Binary Counters allows changing a counter unit in powers of 10 to accommodate a 32-bit counter value to 16-bit BC object format.

<sup>3</sup> The Select Before Operate command causes the meter to start a timer. The following Operate command must be sent before the specified timeout value expires.

<sup>4</sup> The meter requests time synchronization by bit 4 in the first octet of the internal indication word being set to 1 when the time interval specified by the Time Sync Period elapses. The master should synchronize the time in the meter by sending the Time and Date object to clear this bit. The meter does not send time synchronization requests if the Time Sync Period is set to 0.

If the scaling unit is greater than 1, the counter value is reported being divided by the selected scaling unit from 10 to 1000. To get the actual value, multiply the counter reading by the scaling unit.

## 13.2.2 Configuring DNP Class 0 Responses

The most common method of getting static object information from the meter via DNP is to issue a read Class 0 request. The PM17X PRO allows you to configure the Class 0 response by assigning ranges of points to be polled via Class 0 requests.

### To view or build a DNP Class 0 response message:

1. Select Protocol Setup from the Meter Setup menu and click on the DNP Class 0 Points tab.
2. Select the object and variation type for a point range.
3. Specify the start point index and the number of points in the range. Refer to the PM17X PRO DNP3 Reference Guide for available data points.
4. Repeat these steps for all point ranges you want to be included into the Class 0 response.
5. Click Send to download your setup to the meter.

The factory-set Class 0-point ranges are shown in the picture below.

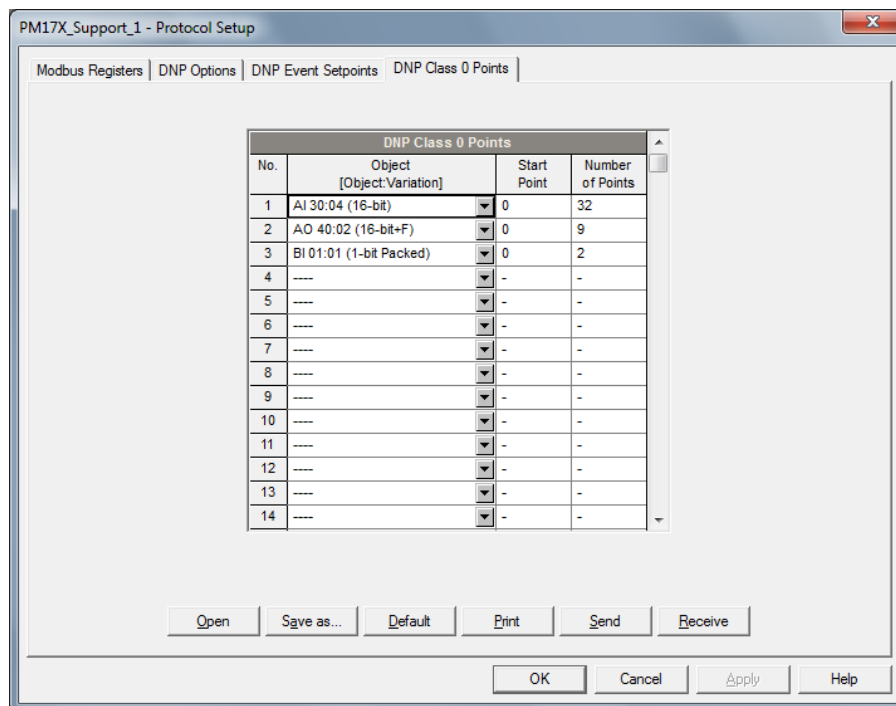

Figure 13-4 Protocol Setup Dialog Box – DNP Class 0 Points Tab

## 13.3 Configuring IEC 60870-5

The PM17X PRO protocol stack is implemented in a very flexible manner. Most of IEC 60870-5-101/104 protocol features are user-configurable allowing easy adaptation for use in different IEC 60870-5 installations. To keep maximum interoperability with master RTU and SCADA systems, the PM17X PRO supports all standard ASDU types for data interrogation, event reporting and control.

The support PAS configuration software supplied with the meter provides all necessary tools for remote configuration of the meter via serial ports or via a TCP/IP Internet connection using either IEC 60870-5-101/104, or Modbus protocol.

The PM17X PRO is equipped with two independent Ethernet ports sunning TCP/IP protocol, enabling two independent communication protocols IEC 60870-5-104 to access two different SCADA.

For more information see PM17X PRO IEC 60870-5 communication guide.

### 13.3.1 Configuring IEC 60870-5 Options

To configure the IEC 60870-5 options:

1. Select IEC 60870-5 Setup from the Meter Setup menu.
2. Select the desired Network (1 or 2)

PM17X\_Support\_1 - IEC 60870-5 Setup

IEC 60870-5 Options | IEC 60870-5 Mapped Points and Events Setup | IEC 60870-5 Class 2 Data and Counters Setup

Network: 1

General IEC 60870-5 Options	
Maximum frame length, octets	255
Link address	One octet
Cause of transmission	One octet
Common address of ASDU	One octet
Information object address (IOA)	Two octets
SBO Timeout, s	10
Short pulse duration, ms	500
Long pulse duration, ms	1000
Time sync period, s	0
Local counter freeze period, min	0
Respond with class 1 data to class 2	Disabled
IEC 60870-5-104 Options	
Maximum unacknowledged ASDU	12
Cyclic transmission period, ms	0
Redundant connection IP address #1	0 . 0 . 0 . 0
Redundant connection IP address #2	0 . 0 . 0 . 0
IEC 60870-5-104 IP Redundancy Mode	1

IEC 60870-5 Information Objects	
Measured value mapped address	1
Measured value default type	M_ME_NB_1
Measured value event type	M_ME_TE_1 (CP56Time2a)
Single point mapped address	101
Single point default type	M_SP_NA_1
Single point event type	M_SP_TB_1 (CP56Time2a)
Double point mapped address	201
Double point default type	M_DP_NA_1
Double point event type	M_DP_TB_1 (CP56Time2a)
Integrated totals mapped address	301
Integrated totals default type	M_IT_NA_1
Integrated totals event type	M_IT_TB_1 (CP56Time2a)
Measurement Units	
Voltage Units	V
Current Units	A
Power Units	kW

Buttons: Open, Save as..., Default, Print, Send, Receive, OK, Cancel, Apply, Help

Figure 13-5 Protocol Setup Dialog Box – IEC 60870-5 Options Tab

3. Select desired options.
4. Click Save as... to store your setup in the device site database, and click Send to send the setup to the device

See the following table for available options.

**Table 39**

Parameter	Options	Default	Description
General IEC 60870-5 Options			
Maximum frame length	32-255 octets	255	The maximum length of the transmission frame. In IEC 60870-5-104 it is fixed to 253 octets.
Link address	1-2 octets	1	Link address length
Cause of transmission	1-2 octets	1	Cause of transmission length. In IEC 60870-5-104 it is fixed to 2 octets.
Common address of ASDU	1-2 octets	1	Length of common address of ASDU. In IEC 60870-5-104 it is fixed to 2 octets.
Information object address	1-3 octets	2	Length of information object address In IEC 60870-5-104 it is fixed to 3 octets.
SBO Timeout, s	0-30 s	10	Select-before-operate (SBO) timeout for single point commands with a select qualifier
Short pulse duration, ms	100-3000 ms	500	Short pulse duration for single point commands with a short pulse qualifier
Long pulse duration, ms	100-3000 ms	1000	Long pulse duration for single point commands with a long pulse qualifier
Time sync period, s	1-86400 s, 0=not active	0	The time interval between periodic time synchronization requests
Local counter freeze period, min	1-60 min, 0=not active	0	The period of local counter freeze and spontaneous transmission of integrated totals
Respond with class 1 data to class 2	0=disabled, 1=enabled	Disabled	If enabled, the meter will respond with class 1 data to class 2 requests when there is no class 2 data in transmission
IEC 60870-5-104 Options			
Maximum unacknowledged ASDU	1-32, 0=unlimited	12	The maximum number of unacknowledged ASDU allowed before suspending data transmission. Unlimited when set to 0.
Cyclic transmission period, ms	100-30000 ms, 0=not active	0	The period of cyclic/periodic data transmission via the IEC 60870-5-104 port
Redundant connection IP address #1	0.0.0.0 =not active	0.0.0.0	The IP address of the controlling station for all data transmission
Redundant connection IP address #2	0.0.0.0 =not active	0.0.0.0	The IP address of the redundant controlling station for all data transmission

Parameter	Options	Default	Description
IEC 60870-5-104 IP Redundancy Mode	1 or 2	1	1 - Standard IP Redundancy Mode (Two logical connections between the controlled station and the same controlling station, both logical connections should be open in order to transmit data) 2 - Enhanced IP Redundancy Mode (Two logical connections between the controlled station and 2 different controlling stations, Cyclic/Periodic data can be transmitted on a specific connection even if it is the only open connection)
IEC 60870-5 Information Objects			
Measured value mapped address	1-4095	1	Starting address for mapped static measured value objects
Measured value default type	M_ME_NA_1 M_ME_NB_1 M_ME_NC_1 M_ME_TA_1 M_ME_TB_1 M_ME_TC_1 M_ME_TD_1 M_ME_TE_1 M_ME_TF_1	M_ME_NB_1	The default type of static measured value objects for Read requests
Measured value event type	M_ME_TA_1 M_ME_TB_1 M_ME_TC_1 M_ME_TD_1 M_ME_TE_1 M_ME_TF_1	M_ME_TE_1	The default type of measured value objects for event reporting
Single point mapped address	1-4095	101	Starting address for mapped static single point objects
Single point default type	M_SP_NA_1 M_SP_TA_1 M_SP_TB_1	M_SP_NA_1	The default type of static single point objects for Read requests
Single point event type	M_SP_TA_1 M_SP_TB_1	M_SP_TB_1	The default type of single point objects for event reporting
Double point mapped address	1-4095	201	Starting address for mapped static double point objects
Double point default type	M_DP_NA_1 M_DP_TA_1 M_DP_TB_1	M_DP_NA_1	The default type of static double point objects for Read requests
Double point event type	M_DP_TA_1 M_DP_TB_1	M_DP_TB_1	The default type of double point objects for event reporting
Integrated totals mapped address	1-4095	301	Starting address for mapped static integrated totals objects

Parameter	Options	Default	Description
Integrated totals default type	M_IT_NA_1 M_IT_TA_1 M_IT_TB_1	M_IT_NA_1	The default type of static integrated totals for Read requests
Integrated totals event type	M_IT_TA_1 M_IT_TB_1	M_IT_TB_1	The default type of integrated totals for event reporting
Measurement Units			
Voltage units	0=V, 1=kV	V	Units of voltage measured values
Current units	0=A, 1=kA	A	Units of current measured values
Power units	0=kW, 1=MW	kW	Units of power measured values

**NOTES:**

1. In IEC 60870-5-104 the maximum length of the variable frame, the common address of ASDU, information object address and cause of transmission length are permanently set to values indicated in the table and the optional settings are ignored.
2. Selecting the one-octet information object address length for IEC 60870-5-101 will limit the range of objects to only mapped points in the range of 1 to 255 and will make impossible configuring IEC 60870-5 in the device via IEC 60870-5-101 ports.

## 13.3.2 Remapping Point Addresses and Event Reporting

### NOTE:

The process measurement scales for most analog values depend on your external PT and CT settings and on the voltage and current scales defined in the meter. Configure them in your meter and save to the device site database before configuring event deadbands. See Basic Setup and Device Options Setup in the PM17X PRO Installation and Operation Manual on how to configure these parameters in the meter.

To remap static object, point addresses to the configurable address space and to configure corresponding event objects:

1. Select IEC 60870-5 Setup from the Meter Setup menu, and then click on the IEC 60870-5 Mapped Points and Events Setup tab.
2. Select the desired Network (1 or 2)

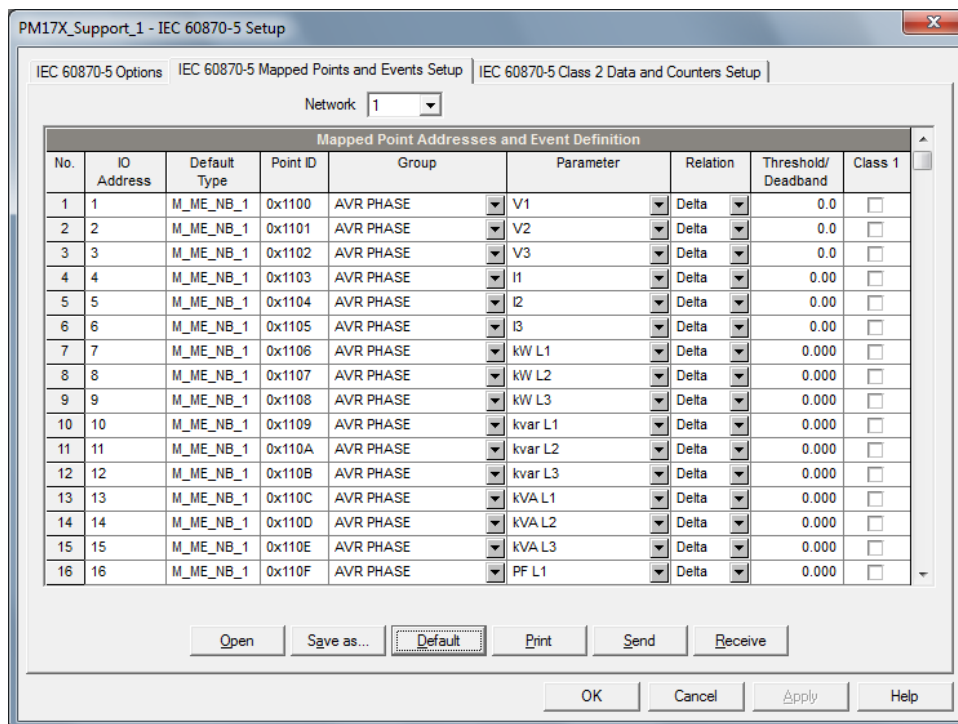

**Figure 13-6 Protocol Setup Dialog Box – IEC 60870-5 Mapped Points and Events Setup Tab**

3. Select an object group and parameter for points you wish to remap. Object types and addresses are assigned automatically upon the starting mapped address and default static type you selected for the type of objects in the IEC 60870-5 Options Setup. When saving the setup to the device database or sending to the meter all points are automatically arranged in the order: measured values, single point objects, double point objects, integrated totals.
4. If you wish to use a static point for reporting events, select a relation and an operating threshold or a deadband to be used for detecting events and check the Class 1 box for the point.

The following options are available:

- Delta – a new event is reported when the absolute value of the difference between the last reported point value and its current value exceeds the specified deadband value, or the status of a binary point changes. Measured values with a zero deadband will not be checked for events;
- More than (over) - a new event is reported when the point value rises over the specified threshold, and then when it returns below the threshold minus a predefined return hysteresis – applicable for measured values;
- Less than (under) - a new event is reported when the point value drops below the specified threshold, and then when it returns above the threshold plus a predefined return hysteresis –applicable for measured values.

Hysteresis of the return threshold for measured values is 0.05 Hz for frequency and 2% of the operating threshold for other points.

All thresholds/deadbands for measured values should be specified in primary units.

- Click Save as... to store your setup in the device site database, and click Send to send the setup to the device.

### 13.3.3 Configuring Class 2 Data and Counter Transmission

This setup allows you to configure object address ranges for interrogation, cyclic/periodic data transmission, and spontaneous counter transmission with or without local freeze/reset.

To configure object address ranges for data transmission:

- Select IEC 60870-5 Setup from the Meter Setup menu, and then click on the IEC 60870-5 Class 2 Data and Counters Setup tab.
- Select the desired Network (1 or 2)

No.	Type	Start IO Address	Number of Points	General Interrogation	Group Interrogation	Cyclic/Spontaneous	Local Freeze	Freeze with Reset
1	M_ME_TE_1 (CP56Time2a)	1	24	<input checked="" type="checkbox"/>	<input checked="" type="checkbox"/>	<input type="checkbox"/>	<input type="checkbox"/>	<input type="checkbox"/>
2	M_IT_TB_1 (CP56Time2a)	301	4	<input checked="" type="checkbox"/>	<input checked="" type="checkbox"/>	<input type="checkbox"/>	<input type="checkbox"/>	<input type="checkbox"/>
3	---	---	---	<input type="checkbox"/>	<input type="checkbox"/>	<input type="checkbox"/>	<input type="checkbox"/>	<input type="checkbox"/>
4	---	---	---	<input type="checkbox"/>	<input type="checkbox"/>	<input type="checkbox"/>	<input type="checkbox"/>	<input type="checkbox"/>
5	---	---	---	<input type="checkbox"/>	<input type="checkbox"/>	<input type="checkbox"/>	<input type="checkbox"/>	<input type="checkbox"/>
6	---	---	---	<input type="checkbox"/>	<input type="checkbox"/>	<input type="checkbox"/>	<input type="checkbox"/>	<input type="checkbox"/>
7	---	---	---	<input type="checkbox"/>	<input type="checkbox"/>	<input type="checkbox"/>	<input type="checkbox"/>	<input type="checkbox"/>
8	---	---	---	<input type="checkbox"/>	<input type="checkbox"/>	<input type="checkbox"/>	<input type="checkbox"/>	<input type="checkbox"/>
9	---	---	---	<input type="checkbox"/>	<input type="checkbox"/>	<input type="checkbox"/>	<input type="checkbox"/>	<input type="checkbox"/>
10	---	---	---	<input type="checkbox"/>	<input type="checkbox"/>	<input type="checkbox"/>	<input type="checkbox"/>	<input type="checkbox"/>
11	---	---	---	<input type="checkbox"/>	<input type="checkbox"/>	<input type="checkbox"/>	<input type="checkbox"/>	<input type="checkbox"/>
12	---	---	---	<input type="checkbox"/>	<input type="checkbox"/>	<input type="checkbox"/>	<input type="checkbox"/>	<input type="checkbox"/>
13	---	---	---	<input type="checkbox"/>	<input type="checkbox"/>	<input type="checkbox"/>	<input type="checkbox"/>	<input type="checkbox"/>
14	---	---	---	<input type="checkbox"/>	<input type="checkbox"/>	<input type="checkbox"/>	<input type="checkbox"/>	<input type="checkbox"/>
15	---	---	---	<input type="checkbox"/>	<input type="checkbox"/>	<input type="checkbox"/>	<input type="checkbox"/>	<input type="checkbox"/>
16	---	---	---	<input type="checkbox"/>	<input type="checkbox"/>	<input type="checkbox"/>	<input type="checkbox"/>	<input type="checkbox"/>

**Figure 13-7 Protocol Setup Dialog Box – IEC 60870-5 Class 2 Data and Counters Setup Tab**

- Select object type and specify ranges of points to be included into interrogation responses or/and cyclic/spontaneous data transmission. Only mapped point addresses and general object addresses can be used for interrogation and cyclic/spontaneous transmission

Up to 32 address ranges can be selected. Fill rows in succession without gaps. The first blank row will be taken as the end of a range list.

**NOTE:**

Though double point objects occupy two adjacent addresses, always specify the actual number of requested double points as you define other object ranges.

Class 2 interrogated and cyclic/spontaneous data are always transmitted in the order they are listed in the setup. If you put ranges of point of the same type at continuous rows, they will be packed together and transmitted using minimum number of frames.

- Check the “General Interrog” box for ranges you wish to include into the general/station interrogation.
- Select appropriate groups in the “Group Interrog” box for ranges you wish to include into group interrogation. Each range of points can be allocated for both global and group interrogation.
- Check the “Cyclic/Spont.” box for ranges you wish to include into cyclic/spontaneous data transmission.

Analog and binary data checked for cyclic transmission will be transmitted as cyclic messages. The IEC 60870-5-104 cyclic data transmission period is configurable via the IEC 60870-5 Options setup.

Integrated totals checked for spontaneous transmission will be transmitted as spontaneous messages at configurable local counter freeze/transmission intervals.

4. Check the “Local Freeze” box for A and B modes of transmission of integrated totals with local freeze.

**NOTE:**

Counters checked for spontaneous transmission without local freeze will be periodically reported at specified counter freeze/transmission intervals either with the frozen counter values if a remote freeze command was issued for counters before (mode D of acquisition of integrated totals), or with the actual counter values for counters that were not frozen.

1. Check the “Freeze with Reset” box for integrated totals for which local freeze with reset should be applied.
2. Click Save as... to store your setup in the device site database, and click Send to send the setup to the device.

## 13.4 Configuring IEC 61850

The PAS software supplied with the PM17X PRO provides a configuration tool for customizing your device and generating a configured IED description (CID) file for use with IEC 61850 client applications.

To reset the IEC 61850 settings to the factory defaults:

1. Select Administration->Master Reset from the Monitor menu.
2. Click the “Reset IEC 61850 Configuration” button, and then confirm the command.

### 13.4.1 Licensing IEC 61850

A valid license key must be provided in the PM17X PRO for IEC 61850 communications. The device is normally shipped with a temporary license, which is valid for a 30-day operation and then can be extended for an additional month.

A permanent license can be obtained from your local distributor for an additional fee. A device serial number must be provided in the license request. The device may also be shipped with the permanent license in the event of a pre-paid fee.

To program a license key in your device:

1. Select Administration->Update License from the Monitor menu.

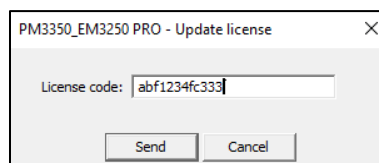

**Figure 13-8**

2. Type in the license code and click Send.

## 13.4.2 Configuring IED Properties

The IEC 61850 configurator allows you to configure the IED name, device location, measurement units and communication options, and to arrange a set of report control blocks for multi-client installations

To configure the IED properties in your device:

1. Select IEC 61850 Setup from the Meter Setup menu, and then click on the IEC 61850 IED Properties tab.
2. Configure IED options for your application as required.

### NOTES

- The configured IED name accompanies logical device names in object references.
  - The device location also identifies the substation location in COMTRADE configuration files as the station\_name attribute.
  - Attributes marked with the asterisk cannot be changed in the device via this setup but you can define and store them to the device database when working offline to use for updating a device CID file.
  - The number of RCB instances defines how pre-defined RCBs are arranged in the device for use in multi-client applications. The RCBs are automatically pre-configured in the device in the way indicated in Section “Reporting model”. The RCB names and report IDs are set to defaults as the number of RCB instances changes. If you intend to change the default setting, set it first before configuring report control blocks.
3. Send your setup to the device and save it to the device database.

PM17X\_Support\_1 - IEC 61850 Setup

GOOSE Subscriber Setup | Report Deadbands | IED Configurator  
 IED Properties | IEC 61850 Datasets | IEC 61850 Reports | GOOSE Publisher Setup

IED Properties	
IED Name	PM17X_Support_1
IEC 61850 Edition	Ed2
Subnet Name	W01
Access Point Name	S1
IP Address *	192 . 168 . 0 . 203
Subnet Mask *	255 . 255 . 255 . 0
Default Gateway *	192 . 168 . 0 . 1
Location	
Client Connection Idle Timeout, min	2
TCP Keepalive Time, s	0
Number of RCB Instances	1 (non-indexed)
Voltage Units	V
Current Units	A
Power Units	kW

\* Configured in the device via Network Setup

Open Save as... **Default** Print Send Receive

OK Cancel Apply Help

Figure 13-9 Protocol Setup Dialog Box – IEC 61850 IED Properties Setup Tab

### 13.4.3 Configuring Datasets

To review or configure the IEC 61850 datasets:

1. Select IEC 61850 Setup from the Meter Setup menu, and then click on the IEC 61850 Datasets tab.
2. Select a dataset you wish to view or configure in the “Dataset Reference” box. Select “New Dataset” to create a new dataset.
3. To delete dataset members, uncheck the appropriate “Included” boxes. Uncheck all dataset members to delete the entire dataset.
4. To add or change dataset members, click “Edit from file”, locate the PM335\_EM235.icd template file or a CID file you generated for your device, and click Open.

A full list of the available data objects and data attributed is displayed, where included dataset members are checked.

To create a new dataset, select a logical device where the dataset will be located and type a dataset name in the “Dataset Name” box.

Check the “Included” boxes for items you wish to be members of the dataset and click OK.

To make easy selection of items across the list, use filters - functional constraints or/and a selected logical device/logical node. Click “Filter checked” to see and revise a list of the selected items.

5. Send your new setup to the device and save it to the device database.

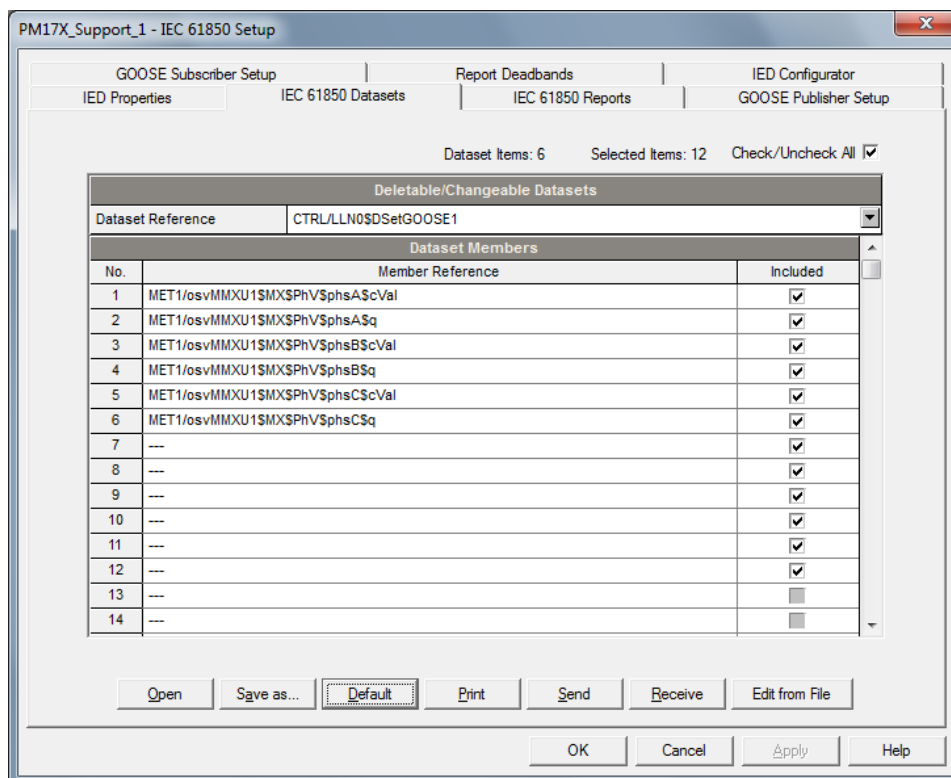

Figure 13-10

### 13.4.4 Configuring Report Control Blocks

To configure Report Control Blocks in your device:

1. Select IEC 61850 Setup from the Meter Setup menu, and then click on the IEC 61850 Reports tab.

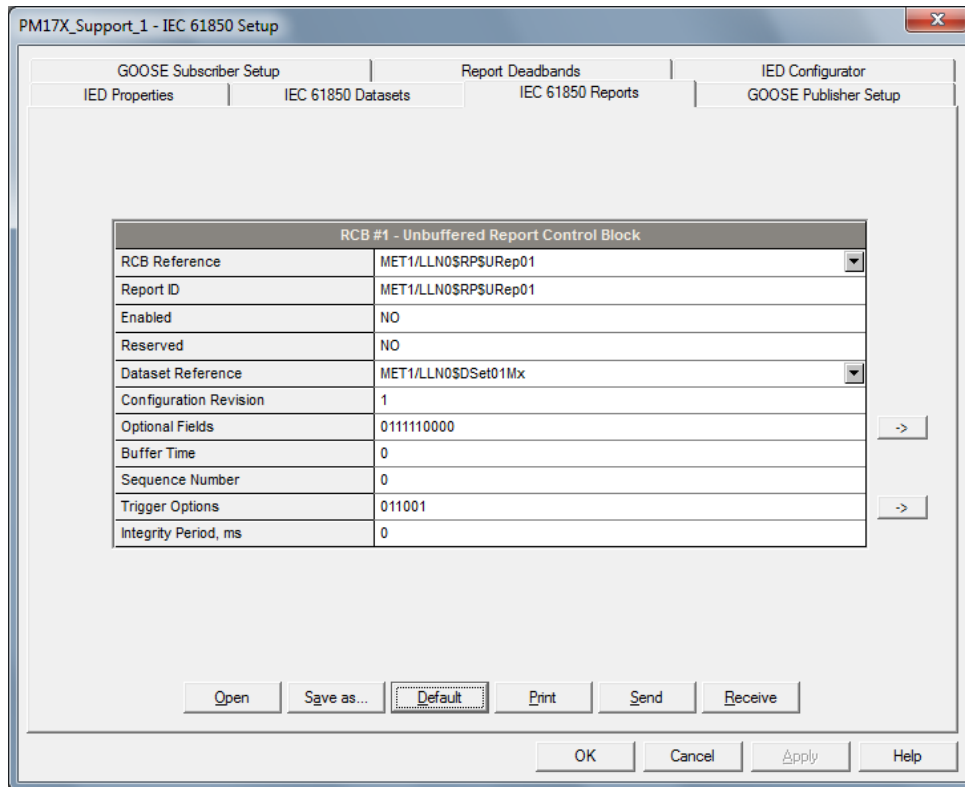

Figure 13-11

2. Select an RCB you wish to view or configure in the "RCB Reference" box.
3. Configure the RCB attributes as required for your application. The following items can be configured:
  - Report ID
  - Dataset reference (can be selected from the available datasets list)
  - Optional fields
  - Trigger options
  - Integrity period for periodic reports with the integrity trigger option selected

To change the Optional fields or Trigger options, click the arrow button at the right to the item, check the appropriate options and click OK.

#### NOTE

Configure your new and customized datasets and update them in the device, or save to the device database if you work offline, before configuring reports; otherwise, you may get an incomplete dataset list.

4. Send your new setup to the device and save it to the device database.

### 13.4.5 Configuring the GOOSE Publisher

The PM17X PRO GOOSE publisher provides the dedicated dataset CTRL/LLN0\$DSetGOOSE1 for GOOSE communications. The default dataset variables list can be modified via the IEC 61850 Datasets setup (see Section 6.3).

To configure the GOOSE publisher:

1. Select IEC 61850 Setup from the Meter Setup menu, and then click on the GOOSE Publisher Setup tab.
2. Configure the destination MAC address, application ID and the maximum message retransmission interval as required for your application. Other setup attributes are not changeable and are indicated for information only.
3. Select Yes in the Publisher Enabled box to enable publisher operation.
4. Send your setup to the device.

PM17X\_Support\_1 - IEC 61850 Setup

GOOSE Subscriber Setup | Report Deadbands | IED Configurator  
 IED Properties | IEC 61850 Datasets | IEC 61850 Reports | GOOSE Publisher Setup

GOOSE Publisher	
GOOSE CB Reference	CTRL/LLN0\$GOSGoCBPub1
Publisher Enabled	NO
GOOSE ID	CTRL/LLN0\$GOSGoCBPub1
Dataset Reference	NONE
Configuration Revision	1
Needs Commissioning	NO
Destination MAC Address	01:0C:CD:01:01:FF
VLAN Priority	4
VLAN ID [hex]	000
APPID [hex]	3001
Max. Retransmission Interval, ms	5000

Open Save as... **Default** Print Send Receive

OK Cancel Apply Help

Figure 13-12

### 13.4.6 Configuring the GOOSE Subscriber

The PM17X PRO can be subscribed to messages sent by any GOOSE network device including both PM17X PRO and non-SATEC devices.

The GOOSE subscriber supports up to 20 subscriptions with up to 16 data elements in each subscription. The location of the subscribed elements in GOOSE data sets and mapping to the PM17X PRO internal variables are configurable. The subscription elements are selected from a publishing device's ICD/CID file.

The PM17X PRO provides a set of internal variables for mapping external GOOSE data:

a 128-bit binary string composed of 128 binary variables ExtInd1...ExtInd128 of type BOOLEAN called external indication and intended for mapping single-point BOOLEAN and integer elements and double-point Dbpos data;

32 variables ExtiVal1...ExtiVal32 of type INT32 for mapping signed and unsigned integer numbers of any size;

32 variables ExtfVal1...ExtfVal32 of type FLOAT32 for mapping single-precision floating point numbers.

When the subscriber receives GOOSE message updates, the subscribed data is copied to the internal variables that can be monitored and recorded in the device like any other measured value. When the subscriber does not receive updates, or the declared message live time has expired, or the data set differs from the subscriber setup, the internal variables are zeroed and the non-active status is indicated in the subscription status.

The subscription status can be monitored from an IEC 61850 client via the GOOSE subscriber logical nodes CTRL/sbsLGOS1-CTRL/sbsLGOS20, or from a Modbus client application via the GOOSE subscriber status register (see the PM17X PRO Modbus Reference Guide for the register location).

To configure the GOOSE subscriber:

1. Select IEC 61850 Setup from the Meter Setup menu, and then click on the GOOSE Subscriber Setup tab.

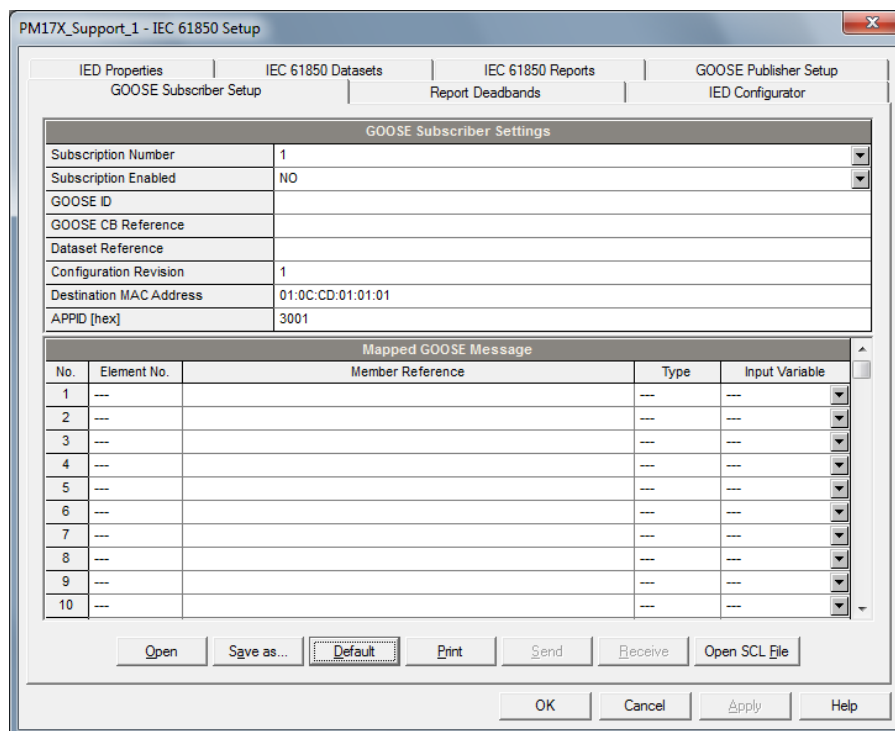

Figure 13-13

2. In the Subscription Number box, select the subscription you wish to configure.

- Click the “Open SCL File” button and open an ICD or CID file for the publishing device you wish to subscribe to. PAS shows you a list of all datasets linked to GOOSE publisher control blocks that are found in the ICD/CID file. Check the Subscribe box for the dataset you wish to subscribe to.

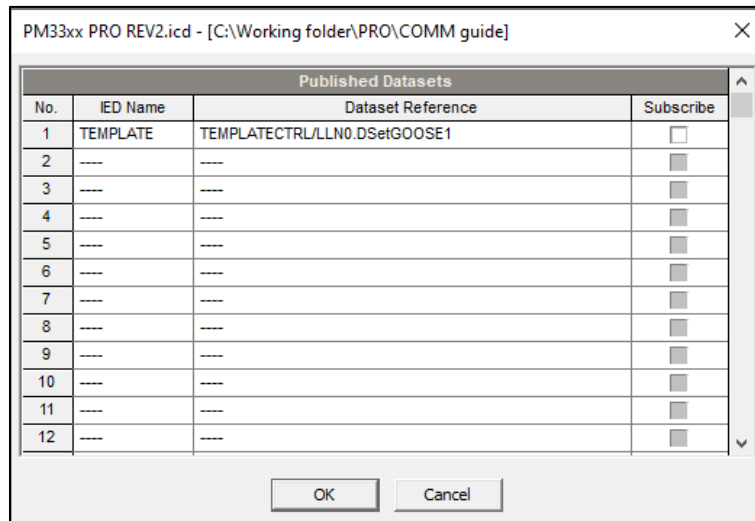

Figure 13-14

- The publisher attributes and a list of dataset members for the selected dataset are displayed as shown in the picture below. PAS also indicates a basic IEC 61850 data element type and a physical MMS type for dataset members. Check the Subscribe boxes for elements you want to subscribe to, and then click OK.

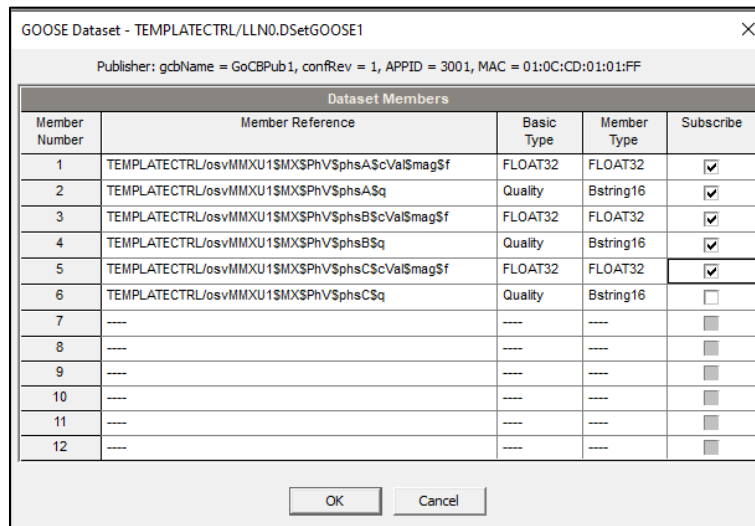

Figure 13-15

You are allowed to select no more than 16 elements. Elements with incompatible data types are not allowed for selection.

The publisher attributes of the selected dataset and the selected data elements are copied to the current subscription.

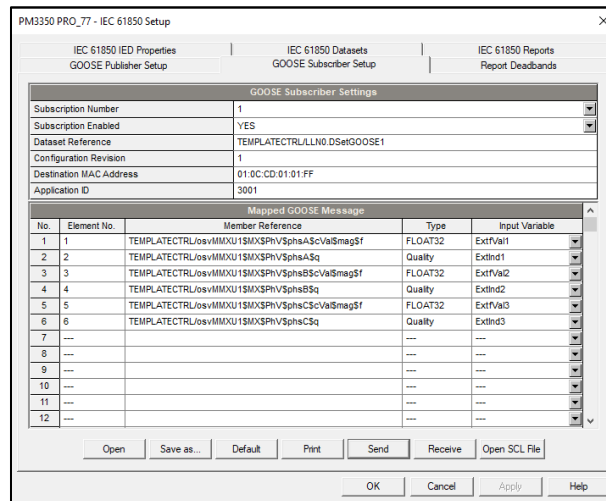

Figure 13-16

Select compatible input variables to which dataset elements will be mapped in the device. See the table below for allowable mapping options depending on the basic variable type.

Table 40

Basic Data Type	MMS Data Type	Compatible Input Variables
BitString32	Bstring32	ExtInd, ExtiVal
Dbpos	Bstring8	ExtInd, ExtiVal
Enum	INT8	ExtInd, ExtiVal
INT32	INT32	ExtInd, ExtiVal
INT32U	INT32U	ExtInd, ExtiVal
INT16	INT16	ExtInd, ExtiVal
INT16U	INT16U	ExtInd, ExtiVal
INT8	INT8	ExtInd, ExtiVal
INT8U	INT8U	ExtInd, ExtiVal
BOOLEAN	BOOLEAN	ExtInd, ExtiVal
FLOAT32	FLOAT32	ExtfVal

## NOTES:

- Mapping integer data to a BOOLEAN ExtInd variable results in copying a least-significant bit of the dataset member only.
  - Mapping double-point data of type Dbpos to a BOOLEAN ExtInd variable causes a high-order bit of the dataset member to be copied to the following BOOLEAN ExtInd variable.
5. Check the application ID, configuration revision and destination MAC address to meet the GOOSE publisher attributes.
  6. Select Yes in the Subscription Enabled box to activate the subscription.
  7. Repeat the setup for other subscriptions you wish to configure, and then send your setup to the device and save to the device database. Notice that dataset member names are not stored in the device and will not be displayed when reading the setup from the device unless you saved the setup in the device database on your PC.

**Note:** GOOSE notification is available only from the ETH1 interface

## Chapter 14 Device Control

This chapter describes how to change device modes, view and clear device diagnostics, and directly operate relay outputs in your PM17X PRO from PAS. To access device control options, you should have your device online.

### Authorization

If your device is password protected you are prompted for the password when you send your first command to the device.

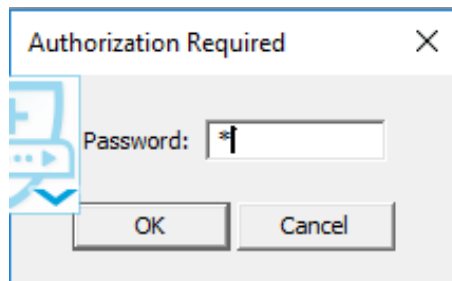



Figure 14-1

Enter the password and click OK. If your authorization was successful, you are not prompted for the password again until you close the dialog window.

## 14.2 Remote Relay Control

From PAS, you can send a command to any relay in your device or release a latched relay, except of the relays that are linked to the internal pulse source. Such relays cannot be operated outside of the device.

To enter the Remote Relay Control dialog, check the On-line  button on the PAS toolbar, select Device Control from the Monitor menu, and then click on the Remote Relay Control tab.

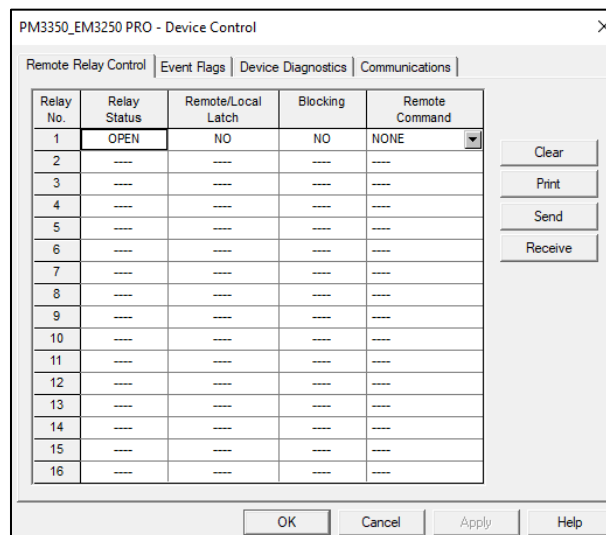

Figure 14-2 Device Control Box – Remote Relay Control Tab

To send a remote command to the relay:

1. From the “Remote Relay Control” box for the relay, select the desired command.
2. Click on Send.

The dialog shows you the present relay status and whether it is latched by a remote command or locally from the setpoints.

## 14.3 Device Event Flags

The PM17X PRO has 64 common event flags that are intended for use as temporary event storage and can be tested and operated from the control setpoints. You can transfer an event to the setpoints and trigger its operation remotely by changing the event status through PAS.

To enter the Event Flags dialog, check the On-line button on the PAS toolbar, select Device Control from the Monitor menu, and then click on the Event Flags tab.

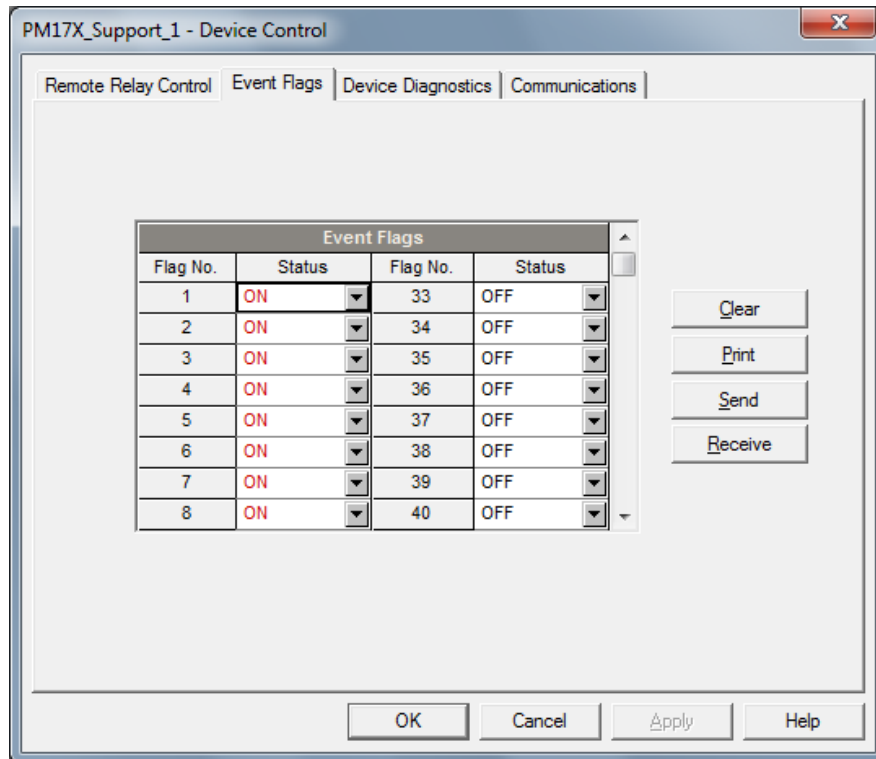

**Figure 14-3 Device Control Box – Event Flags Tab**

To change the status of an event flag:

1. From the "Status" box for the event flag, select the desired flag status.
2. Click on Send.

## 14.4 Viewing and Clearing Device Diagnostics

You can examine the present device diagnostics status and clear it via PAS.

To enter the Device Diagnostics dialog, check the On-line  button on the PAS toolbar, select Device Control from the Monitor menu, and then click on the Device Diagnostics tab.

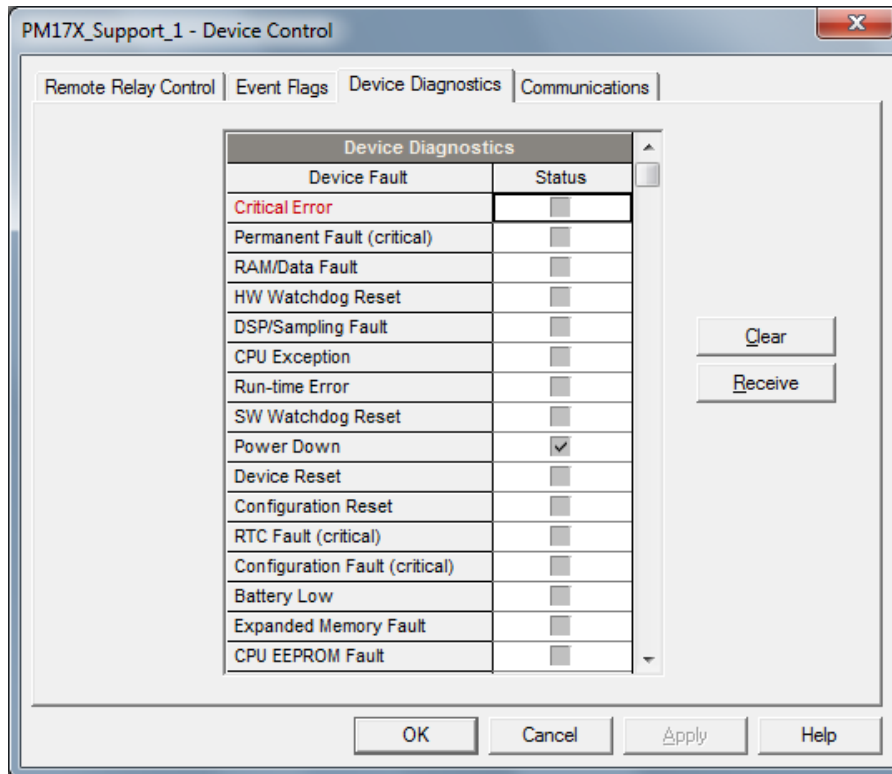

**Figure 14-4 Device Control Box – Event Flags Tab**

To clear the device diagnostics events, click on Clear.

Refer to Device Diagnostic Codes in Chapter 24 for the list of diagnostic codes and their meanings. See Device Diagnostics in Chapter 3 for more information about device diagnostics.

## 14.5 Viewing Communication Status and Statistics

Ensure that the On-line button on the PAS toolbar is checked, select Device Control from the Monitor menu, and then click on the Communications tab.

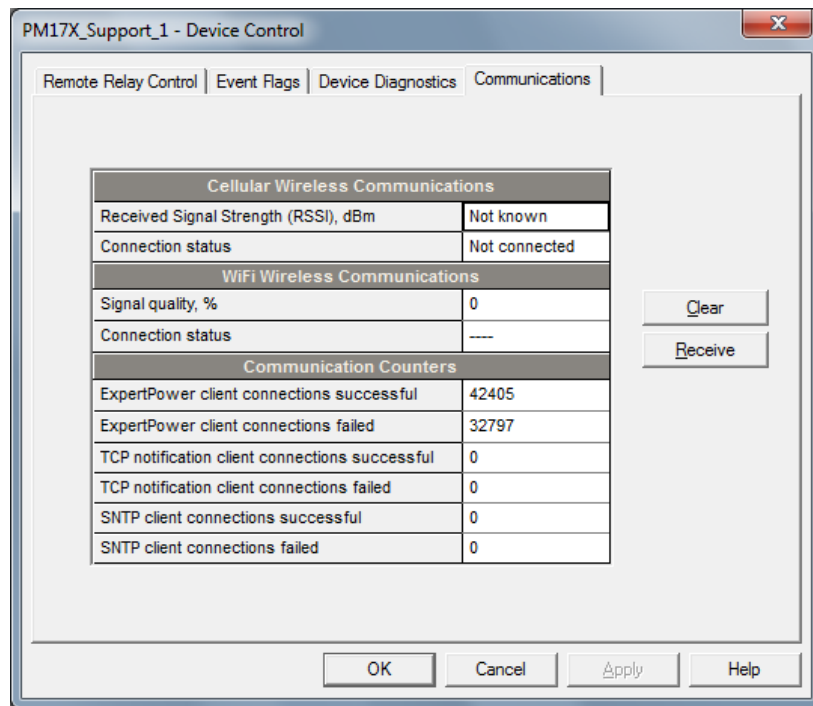

**Figure 14-5 Device Control Dialog Box – Communications Tab**

This window indicates the present GPRS communication status (see [Setting Up Ethernet](#) in Chapter 10) and connection statistics of the TCP clients (see [Configuring eXpertPower Client](#) and [Setting Up TCP Notification Client](#) Chapter 10).

To clear the communication counters, click on Clear.

You can also clear the communications counters via the PAS Reset dialog (see [Resetting Accumulators and Maximum Demands](#)).

## 14.6 Resetting Accumulators and Clearing Log Files

This section describes how to reset accumulators and demand registers and log files (data log and waveform log).

### 14.6.1 Using PAS

PAS allows you to clear energy accumulators, maximum demands, Min/Max log registers, counters and log files in your device. To open the Reset dialog, select a device site from the list box on the toolbar, check the On-line button  on the toolbar, and then select Reset from the Monitor menu.

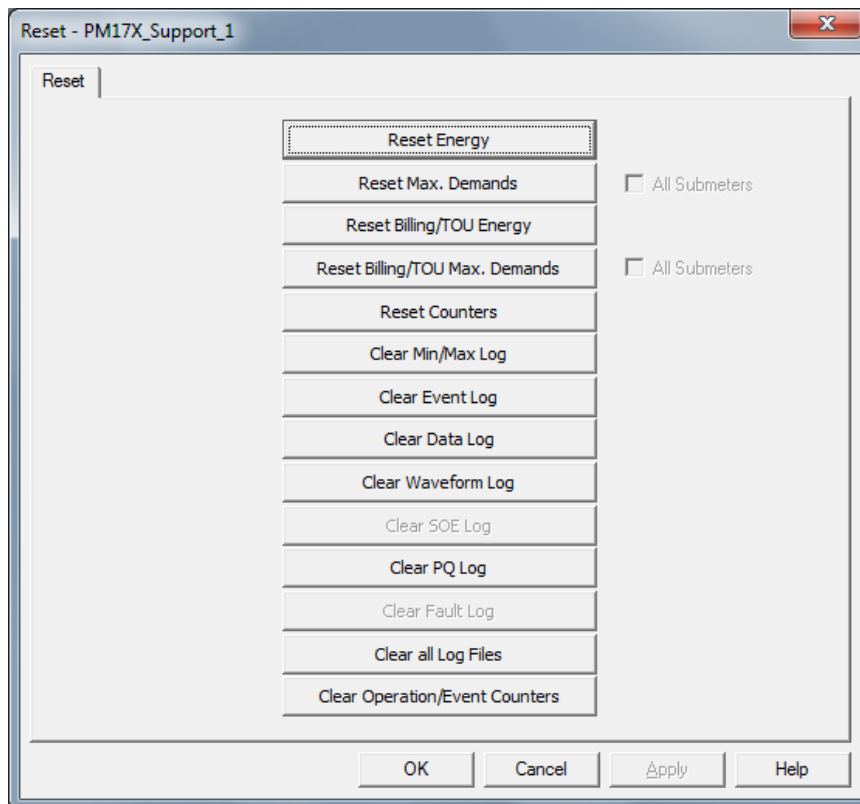

**Figure 14-6 Monitor Box – Reset Tab**

To reset the desired accumulation registers or to clear a file, click on the corresponding button. If a target has more than one component, you are allowed to select components to reset. Check the corresponding boxes, and then click OK.

This section describes operations on the meter you can perform from the PAS. To access device control options from PAS, you should have your meter online.

To reset the desired values or files:

1. Click on the corresponding button, and then confirm your command.
2. If an entry has more than one target, you are allowed to select targets to reset.
3. Check the corresponding boxes, and then click OK.

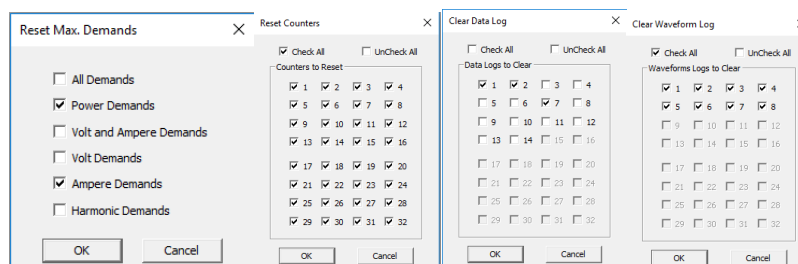

**Figure 14-7 Multi Targets Reset Dialog Box**

## Chapter 15 Monitoring Meters

### 15.1 Viewing Real-time Data

Real-time data is continuously retrieved from your devices and updated on the screen at the rate you defined in the Instrument Setup.

To get real-time data from your device, select the device site from the list box on the PAS toolbar, point to RT Data Monitor on the Monitor menu, and then select a data set you want to view.

#### 15.1.1 Organizing Data Sets

PAS supports 33 programmable data sets with up to 40 data parameters. Set #0 is intended for simple meters, which have a limited number of parameters, and is not recommended for the use with the PM17X

PRO. To re-organize data sets, select Data Set from the Monitor menu or click on the button  on the local toolbar. Real-time data can be continuously retrieved from your devices and updated on the screen at the rate you defined in the Instrument Setup.

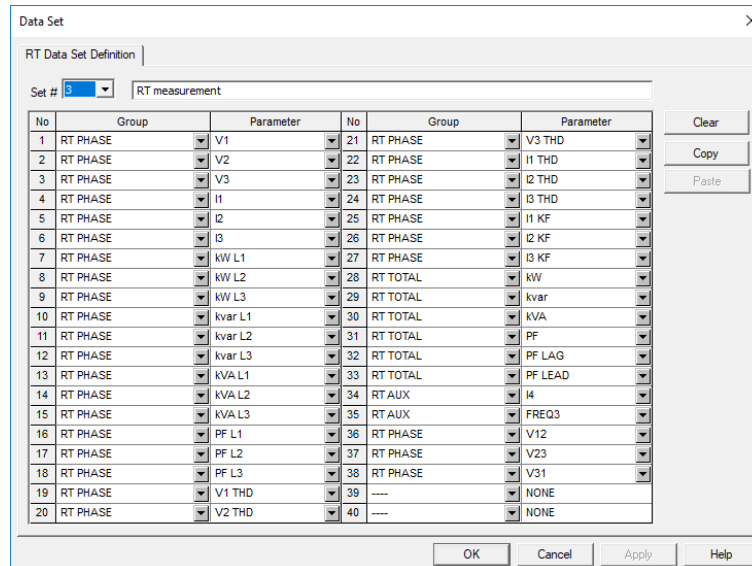





The screenshot shows the 'Data Set' configuration window with the 'RT Data Set Definition' tab selected. The 'Set #' dropdown is set to '0'. The window contains a table with 40 rows, each representing a data parameter. The table is organized into two columns of 20 rows each. Each row has a 'No.' column, a 'Group' dropdown menu, and a 'Parameter' dropdown menu. The parameters listed include various voltage (V1, V2, V3, V1 THD, V2 THD, V3 THD), current (I1, I2, I3, I1 KF, I2 KF, I3 KF), power (kW L1, kW L2, kW L3, RT TOTAL, kW, kvar, kVA, PF, PF LAG, PF LEAD), and auxiliary (RT AUX, I4, FREQ3) measurements. The last two rows (39 and 40) are empty, with 'NONE' selected in the parameter dropdown.

No.	Group	Parameter	No.	Group	Parameter
1	RT PHASE	V1	21	RT PHASE	V3 THD
2	RT PHASE	V2	22	RT PHASE	I1 THD
3	RT PHASE	V3	23	RT PHASE	I2 THD
4	RT PHASE	I1	24	RT PHASE	I3 THD
5	RT PHASE	I2	25	RT PHASE	I1 KF
6	RT PHASE	I3	26	RT PHASE	I2 KF
7	RT PHASE	kW L1	27	RT PHASE	I3 KF
8	RT PHASE	kW L2	28	RT TOTAL	kW
9	RT PHASE	kW L3	29	RT TOTAL	kvar
10	RT PHASE	kvar L1	30	RT TOTAL	kVA
11	RT PHASE	kvar L2	31	RT TOTAL	PF
12	RT PHASE	kvar L3	32	RT TOTAL	PF LAG
13	RT PHASE	kVA L1	33	RT TOTAL	PF LEAD
14	RT PHASE	kVA L2	34	RT AUX	I4
15	RT PHASE	kVA L3	35	RT AUX	FREQ3
16	RT PHASE	PF L1	36	RT PHASE	V12
17	RT PHASE	PF L2	37	RT PHASE	V23
18	RT PHASE	PF L3	38	RT PHASE	V31
19	RT PHASE	V1 THD	39	----	NONE
20	RT PHASE	V2 THD	40	----	NONE

**Figure 15-1 RT Measurement Data Set definition**

Some data sets are preset for your convenience and others are empty. You can freely modify data sets.

## 15.1.2 Polling Devices

To run data polling, check the On-line button  on the PAS toolbar, and then click on either the Poll button  or Continuous Poll button  on the local toolbar. Click on the Stop button  to stop continuous polling,

You can open as many data monitor windows as you wish, either for different sites, or for the same site using different data sets.

An open data monitor window is linked to the current site and does not change if you select another site in the site list.

You can view acquired data in a tabular form or in a graphical form as a data trend.

The following picture shows a typical data monitor window.

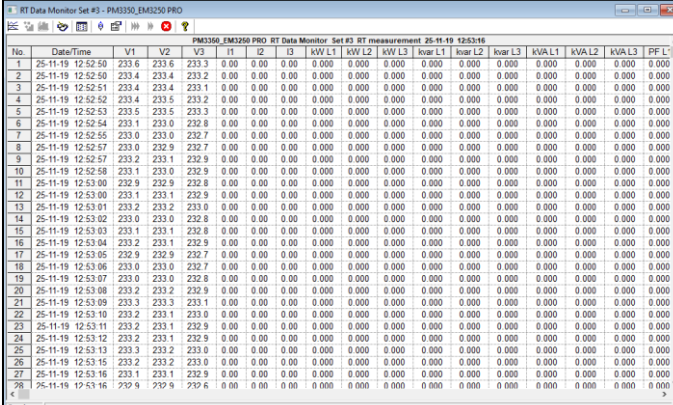

No.	Date/Time	V1	V2	V3	I1	I2	I3	kW L1	kW L2	kW L3	kvar L1	kvar L2	kvar L3	kVA L1	kVA L2	kVA L3	PF L
1	25-11-19 12:52:50	233.6	233.6	233.3	0.00	0.00	0.00	0.000	0.000	0.000	0.000	0.000	0.000	0.000	0.000	0.000	0.000
2	25-11-19 12:52:50	233.4	233.4	233.2	0.00	0.00	0.00	0.000	0.000	0.000	0.000	0.000	0.000	0.000	0.000	0.000	0.000
3	25-11-19 12:52:51	233.4	233.4	233.1	0.00	0.00	0.00	0.000	0.000	0.000	0.000	0.000	0.000	0.000	0.000	0.000	0.000
4	25-11-19 12:52:52	233.4	233.5	233.2	0.00	0.00	0.00	0.000	0.000	0.000	0.000	0.000	0.000	0.000	0.000	0.000	0.000
5	25-11-19 12:52:53	233.5	233.5	233.3	0.00	0.00	0.00	0.000	0.000	0.000	0.000	0.000	0.000	0.000	0.000	0.000	0.000
6	25-11-19 12:52:54	233.1	233.0	232.8	0.00	0.00	0.00	0.000	0.000	0.000	0.000	0.000	0.000	0.000	0.000	0.000	0.000
7	25-11-19 12:52:55	233.0	233.0	232.7	0.00	0.00	0.00	0.000	0.000	0.000	0.000	0.000	0.000	0.000	0.000	0.000	0.000
8	25-11-19 12:52:57	233.0	232.9	232.7	0.00	0.00	0.00	0.000	0.000	0.000	0.000	0.000	0.000	0.000	0.000	0.000	0.000
9	25-11-19 12:52:57	233.2	233.1	232.9	0.00	0.00	0.00	0.000	0.000	0.000	0.000	0.000	0.000	0.000	0.000	0.000	0.000
10	25-11-19 12:52:58	233.1	233.0	232.9	0.00	0.00	0.00	0.000	0.000	0.000	0.000	0.000	0.000	0.000	0.000	0.000	0.000
11	25-11-19 12:53:00	232.9	232.9	232.8	0.00	0.00	0.00	0.000	0.000	0.000	0.000	0.000	0.000	0.000	0.000	0.000	0.000
12	25-11-19 12:53:00	233.1	233.1	232.9	0.00	0.00	0.00	0.000	0.000	0.000	0.000	0.000	0.000	0.000	0.000	0.000	0.000
13	25-11-19 12:53:01	233.2	233.2	233.0	0.00	0.00	0.00	0.000	0.000	0.000	0.000	0.000	0.000	0.000	0.000	0.000	0.000
14	25-11-19 12:53:02	233.0	233.0	232.8	0.00	0.00	0.00	0.000	0.000	0.000	0.000	0.000	0.000	0.000	0.000	0.000	0.000
15	25-11-19 12:53:03	233.1	233.1	232.8	0.00	0.00	0.00	0.000	0.000	0.000	0.000	0.000	0.000	0.000	0.000	0.000	0.000
16	25-11-19 12:53:04	233.2	233.1	232.9	0.00	0.00	0.00	0.000	0.000	0.000	0.000	0.000	0.000	0.000	0.000	0.000	0.000
17	25-11-19 12:53:05	232.9	232.9	232.7	0.00	0.00	0.00	0.000	0.000	0.000	0.000	0.000	0.000	0.000	0.000	0.000	0.000
18	25-11-19 12:53:06	233.0	233.0	232.7	0.00	0.00	0.00	0.000	0.000	0.000	0.000	0.000	0.000	0.000	0.000	0.000	0.000
19	25-11-19 12:53:07	233.0	233.0	232.8	0.00	0.00	0.00	0.000	0.000	0.000	0.000	0.000	0.000	0.000	0.000	0.000	0.000
20	25-11-19 12:53:08	233.2	233.2	232.9	0.00	0.00	0.00	0.000	0.000	0.000	0.000	0.000	0.000	0.000	0.000	0.000	0.000
21	25-11-19 12:53:09	233.3	233.3	233.1	0.00	0.00	0.00	0.000	0.000	0.000	0.000	0.000	0.000	0.000	0.000	0.000	0.000
22	25-11-19 12:53:10	233.2	233.1	233.0	0.00	0.00	0.00	0.000	0.000	0.000	0.000	0.000	0.000	0.000	0.000	0.000	0.000
23	25-11-19 12:53:11	233.2	233.1	232.9	0.00	0.00	0.00	0.000	0.000	0.000	0.000	0.000	0.000	0.000	0.000	0.000	0.000
24	25-11-19 12:53:12	233.2	233.1	232.9	0.00	0.00	0.00	0.000	0.000	0.000	0.000	0.000	0.000	0.000	0.000	0.000	0.000
25	25-11-19 12:53:13	233.3	233.2	233.0	0.00	0.00	0.00	0.000	0.000	0.000	0.000	0.000	0.000	0.000	0.000	0.000	0.000
26	25-11-19 12:53:15	233.2	233.2	233.0	0.00	0.00	0.00	0.000	0.000	0.000	0.000	0.000	0.000	0.000	0.000	0.000	0.000
27	25-11-19 12:53:16	233.1	233.1	232.9	0.00	0.00	0.00	0.000	0.000	0.000	0.000	0.000	0.000	0.000	0.000	0.000	0.000
28	25-11-19 12:53:16	232.9	232.9	232.6	0.00	0.00	0.00	0.000	0.000	0.000	0.000	0.000	0.000	0.000	0.000	0.000	0.000

Figure 15-2 RT Data Monitor Set#3 – RT measurement

### Polling Options

To change the polling options, click on the Data Monitor window with the right mouse button and select Options.

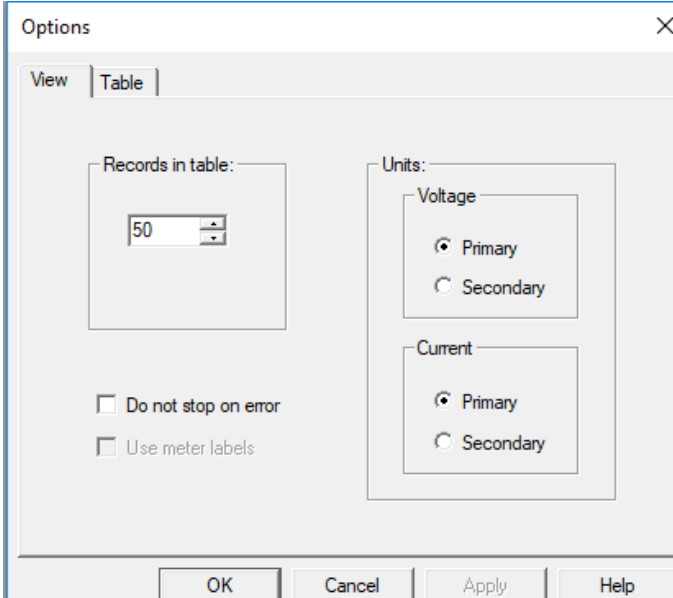

Figure 15-3 RT Data Monitor Set#3 – Polling options

If you check “Do not stop on errors”, polling is resumed automatically when a communication error occurs, otherwise polling stops until you restart it manually.

### 15.1.3 Viewing a Data Table

#### Changing the Data View

PAS displays data in either a single record or multi-record view. To change the view, click on the Data Monitor window with the right mouse button and select either Wrap to see a single record, or Unwrap to go to the multi-record view.



#### Adjusting the Number of Rows in a Multi-Record View

Click the window with the right mouse button, select Options, adjust the number of records you want to see in the window, and then click OK. When the number of retrieved records exceeds the number of rows in the window, the window scrolls up so that older records are erased.

#### Selecting Primary and Secondary Units

Voltages and currents can be displayed in primary or secondary units. To select primary or secondary units for your data views, click on the monitor window with the right mouse button, select Options, select the desired units for voltages and currents, and then click OK.

### 15.1.4 Viewing Data Trend

To view a data trend, click on the  button on the local toolbar. To change the time range for your graph, click on the  button on the local toolbar, and then select the desired date and time range.

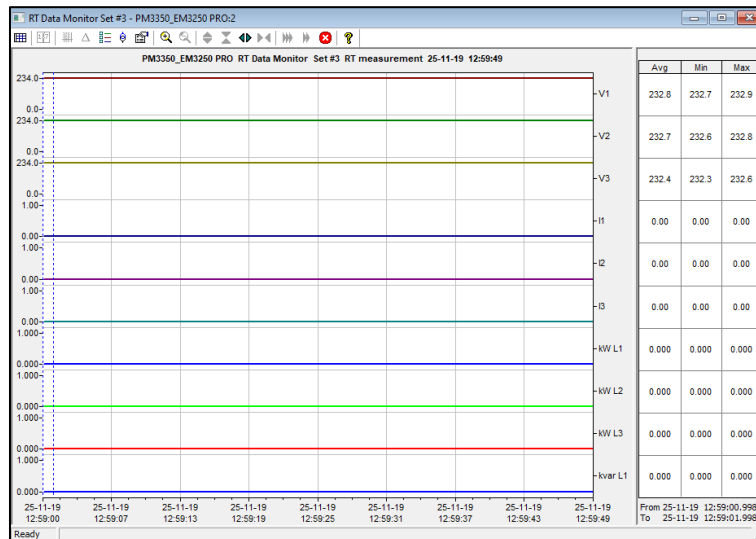

Figure 15-4 RT Data Monitor Set#3 – Data trend

#### Selecting Channels

To select data channels for your trend, click on the trend window with the right mouse button, select “Channels”, check the channels you want displayed, and then click OK.

#### Customizing Line Colors and Styles

Trend lines for different channels can be shown in different colors using different line styles. To change the colors or line styles, click on the trend window with the right mouse button, select “Options...”, click on the “Display” tab, adjust colors and styles for channels, and then click OK. You can also change the colors for the background and gridlines.

## Using the Marker Lines



The trend window has two blue dashed marker lines. The left marker indicates the starting position for calculating the average and peak values, and the right marker indicates the end position.

To change the marker position, click on the trend window with the right mouse button and select Set Marker, or click on the  button on the window toolbar, and then click with left mouse button on the point where you want to put the marker. You can also drag both markers with the mouse, or use the right and left arrow keys on your keyboard to change the marker position. Click on the trend pane with the mouse before using the keyboard, to allow the keyboard to get your input.

## Delta Measurements

To measure the distance between two trend points, click on the Delta button  on the toolbar, click with the left mouse button on the first point, and then click on the second point. The first reference point is frozen until you close and reopen Delta, while the second point can be placed anywhere within the trend line. You can measure a delta in both directions. To disable Delta, click on the Delta button again.

## Using a Zoom

You can use a horizontal and a vertical zoom to change size of your graph. Use the buttons  on your local toolbar representing green arrowheads to zoom in or out of the trend graph. Every click on these buttons gives you a 100-percent horizontal zoom. Two buttons  representing a magnifying glass give you a proportional zoom in both directions.

### 15.1.5 Saving Data to a File



To save retrieved data to a file for later analysis, click on the Save button , select a directory where you want your log files to be stored, select a database or type the name for a new database, and then click Save. To avoid confusion, do not store data files into the "Sites" directory where site databases are located.

### 15.1.6 Printing Data

To print retrieved data, click the  button on the PAS toolbar, select a printer, and then click OK. To check the report, as it will look when printed, select Print Preview from the File menu.

### 15.1.7 Copying Data

To copy the entire data table or a part of a table into the Clipboard or into another application such as Microsoft Excel or Word:

1. Click on the Data Monitor window with the right mouse button and choose Select All, or click on the upper-left corner of the data table (where the "No." label is displayed).
2. Click on the Data Monitor window with the right mouse button again and choose Copy or click on the Copy button  on the PAS toolbar.
3. Run an application to where you want to copy data, position cursor at the correct place, and then click on the Paste button  on the application's toolbar, or select Paste from the Edit menu.

If you want only a part of data to be copied, select with the mouse while holding the left mouse button the rows or columns in the table you want to copy, and then click on the Copy button  on the PAS toolbar.

### 15.1.8 Real-time Data Logging

PAS allows you to log polled data records to a database automatically at the time it updates the Data Monitor window on the screen.

To setup the real-time logging options:



1. Open the Data Monitor window.
2. Click on the "RT Logging On/Off"  button on the local toolbar, or select "RT Logging Options" from the Tools menu.
3. Select a database, or type the name for a new database and select a directory where you want to save it.
4. Select the number of tables, and the number of records in each table you want recorded.
5. Adjust the file update rate for automatic recording. It must be a multiple of the sampling rate that you defined in the Instrument Setup dialog.
6. Click Save.

When you run real-time data polling, PAS automatically saves retrieved records to the database at the rate you specified. The "RT Logging On/Off" button  on the toolbar should be checked all the time to allow PAS to perform logging. You can suspend logging by un-checking this button, and then resume logging by checking it again.

## 15.2 Viewing Real-time Min/Max Log

To retrieve the real-time Min/Max log data from your device, select the device site from the list box on the PAS toolbar, point to RT Min/Max Log on the Monitor menu, and then select a data set you want to view.





PAS supports nine programmable data sets with up to 40 data parameters in each one. To re-organize data sets, select Data Set from the Monitor menu or click on the  button on the toolbar. You can modify data sets in the way that is convenient for your use.

To retrieve the selected Min/Max log data, check the On-line button  on the PAS toolbar, and then click on the Poll button .

You can save retrieved data to a file or print it in the same manner as described in the previous section.

## 15.3 Viewing Real-time Waveforms

To retrieve the real-time waveforms from your device, select the device site from the list box on the toolbar, and then select RT Waveform Monitor from the Monitor menu.

To retrieve waveforms, check the On-line button  on the PAS toolbar, and then click on either the Poll button  or Continuous poll button . Click on the Stop button  to stop continuous polling.



PAS normally retrieves eight 4-cycle AC waveforms (V1-V4 and I1-I4) sampled at a rate of 128 samples per cycle. If you wish to get only waveforms for selected phases, select "Options" from the Tools menu, click on the Preferences tab, check the phases you want polled, and then click OK.

To view AI waveforms, or to change channels displayed in the window, click on the waveform window with the right mouse button, select "Channels", check channels you want displayed, and then click OK.

Retrieved waveforms can be displayed in different views as overlapped or non-overlapped waveforms, as RMS cycle-by-cycle plot, or as a harmonic spectrum chart or table. See [Viewing Waveforms](#) in Chapter 17 for information on using different waveform views.

## 15.4 Viewing Real-time Min/Max Log



To retrieve the real-time Min/Max log data from your meter:



1. Select the device site from the list box on the PAS toolbar.
2. Point to RT Min/Max Log on the Monitor menu, and then select a data set you want to view.
3. Ensure that the On-line button  on the PAS toolbar is checked.
4. Click on the Poll button .

PAS supports 9 programmable data sets that you can organize as you wish. To build your data sets, select MinMax Data Sets from the Monitor menu or click on the  button on the local toolbar.

## 15.5 Viewing Real-time Waveforms

To retrieve real-time waveforms from your meter:

1. Ensure that the On-line button  on the PAS toolbar is checked.
2. Select the device site from the list box on the toolbar.
3. Select RT Waveform Monitor from the Monitor menu or click on the  button on the PAS toolbar.

Use the Poll button  for a single-step poll or the Continuous poll  button for continuous polling.

To stop continuous polling, click on the Stop button .

The meter provides simultaneous capture of six one-cycle voltage and current AC waveforms at a rate of 64 samples per cycle. To give you a more representative picture, PAS extends the waveforms across the window up to eight cycles by repeating the captured waveforms.

To select the channels you want to view, click with the right mouse button on the waveform window, select Channels..., check the channels for the phase you want displayed, and then click OK.

Retrieved waveforms can be displayed in different views as overlapped or non-overlapped waveforms, as RMS cycle-by-cycle plot, or as a harmonic spectrum chart or table.

### Viewing a Waveform Graph

When you open a new file, PAS shows you a waveform graph with non-overlapped waveforms as shown in the picture above.

Click on the  button on the local toolbar to see overlapped waveforms.

Click on the  button for non-overlapped waveforms.

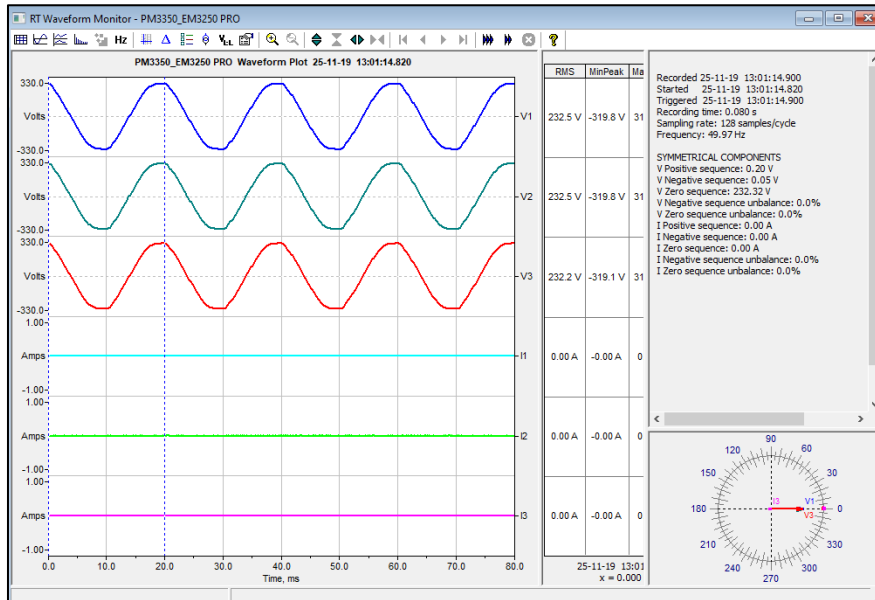



Figure15-5 RT Waveform Monitor Window

## Viewing a Frequency Plot

Click on the **Hz** button to view a cycle-by-cycle frequency plot for the sampled voltage waveforms.

## Viewing a Harmonic Spectrum

Click on the  button to view a spectrum chart for the selected waveform channel. PAS provides voltage, current, active power and reactive power spectrum charts. See [Viewing Real-time Harmonic Spectrum](#) for more information on viewing options.

## Viewing Phasor Diagrams

The phasor diagrams show you relative magnitudes and angles of the three-phase voltage and current fundamental component. All angles are shown relative to the reference voltage channel.

To change the reference channel, click on the waveform window with the right mouse button, select Options..., click on the Phasor tab, check the channel you want to make a reference channel, and then click OK.

## Viewing Symmetrical Components

Waveform views have an additional pane at the right where PAS displays the symmetrical components for voltages and currents, calculated for the point indicated by the left marker line.

To enable or disable the symmetrical components, click on the waveform window with the right mouse button, select Options..., check or uncheck the Symmetrical components box on the Channels tab, and then click OK.



## Viewing Phase-to-phase Voltages



PAS can transform phase-to-neutral voltage waveforms in configurations with a neutral into phase-to-phase waveforms allowing you to view the waveshape, angle relationships and harmonics of the phase-to-phase voltages.

Click on the  button on the waveform window toolbar. Click the button once again to return to phase-to-neutral waveforms.

## 15.6 Viewing Real-time Harmonic Spectrum

To retrieve real-time harmonic spectrum from your meter:

1. Ensure that the On-line button  on the PAS toolbar is checked.
2. Select the device site from the list box on the toolbar.
3. Select RT Harmonic Monitor from the Monitor menu or click on the  button on the PAS toolbar.

Click on the “Poll”  or “Continuous poll”  button to poll the meter once or continuously. Click on the Stop button  to stop continuous polling.

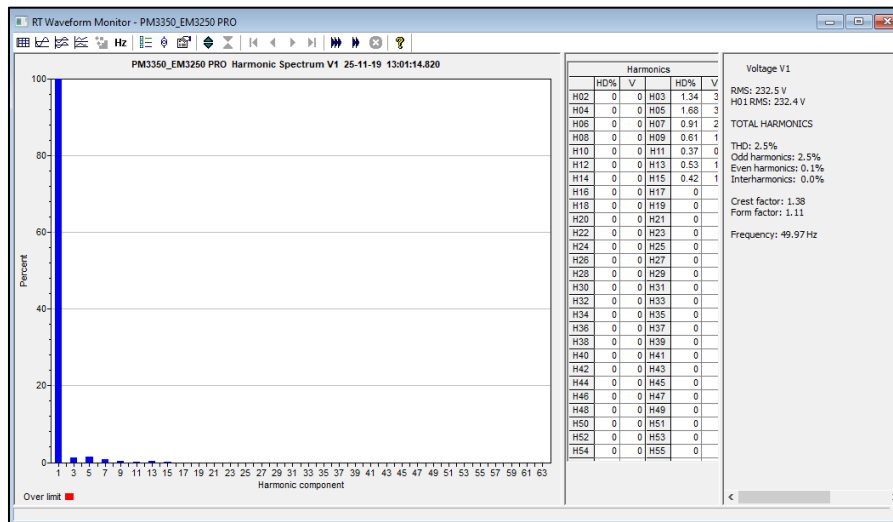

**Figure 15-6 RT Harmonic Monitor – Spectrum Chart**

PAS retrieves harmonic spectrum for V1-V3 and I1-I3 channels. Harmonics can be displayed as a spectrum chart for a selected channel or in a table. PAS can also synthesize waveforms based on the harmonic spectrum to let you view a shape of the voltage and current waveforms in your network.

## Viewing a Spectrum Chart

Click on the  button to view a spectrum chart for the selected channel. To change a channel, click on the window with the right mouse button, select Channels..., check the channel you want displayed, and then click OK. PAS provides voltage, current, active power and reactive power spectrum charts.

PAS can give you indication on whether harmonic levels in the sampled waveforms exceed compliance limits defined by the power quality standards or local regulations.

To review or change harmonic limits:

1. Click on the spectrum window with the right mouse button and select Limits....
2. Select a known harmonics standard, or select Custom and specify your own harmonic limits.
3. Check the Enabled box to visualize harmonic faults on the spectrum graph and in harmonic tables.

Harmonics that exceed selected compliance levels are colored in red on the graph and in the tables.

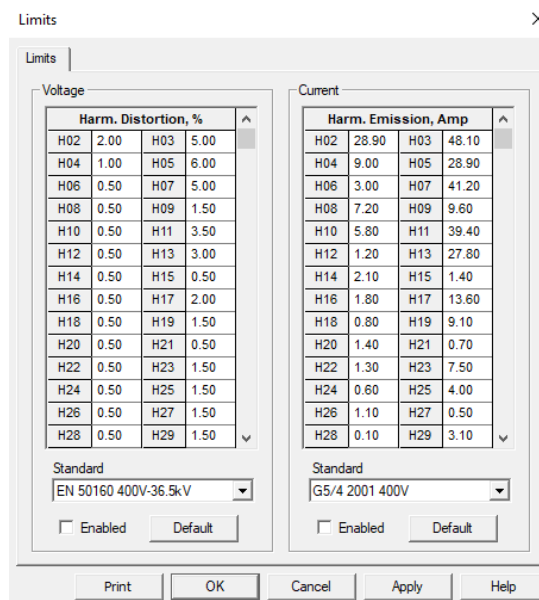

The screenshot shows the 'Limits' dialog box with two main sections: 'Voltage' and 'Current'. Each section contains a table of harmonic limits, a 'Standard' dropdown menu, and an 'Enabled' checkbox with a 'Default' button.

Voltage		Current	
Harm. Distortion, %		Harm. Emission, Amp	
H02	2.00	H03	5.00
H04	1.00	H05	6.00
H06	0.50	H07	5.00
H08	0.50	H09	1.50
H10	0.50	H11	3.50
H12	0.50	H13	3.00
H14	0.50	H15	0.50
H16	0.50	H17	2.00
H18	0.50	H19	1.50
H20	0.50	H21	0.50
H22	0.50	H23	1.50
H24	0.50	H25	1.50
H26	0.50	H27	1.50
H28	0.50	H29	1.50

Standard: EN 50160 400V-36.5kV (Voltage) / G5/4 2001 400V (Current)

Buttons: Print, OK, Cancel, Apply, Help

Figure 15-7 Harmonic Limits

## Viewing a Spectrum Table

Click on the  button on the local toolbar to display the harmonics spectrum in a tabular view for a selected phase or for all phases together.

The spectrum table shows voltage, current, active power and reactive power harmonic components both in percent of the fundamental and in natural units, and harmonic phase angles.

To change a phase, click on the window with the right mouse button, select Options..., check the phase you want displayed, and then click OK.

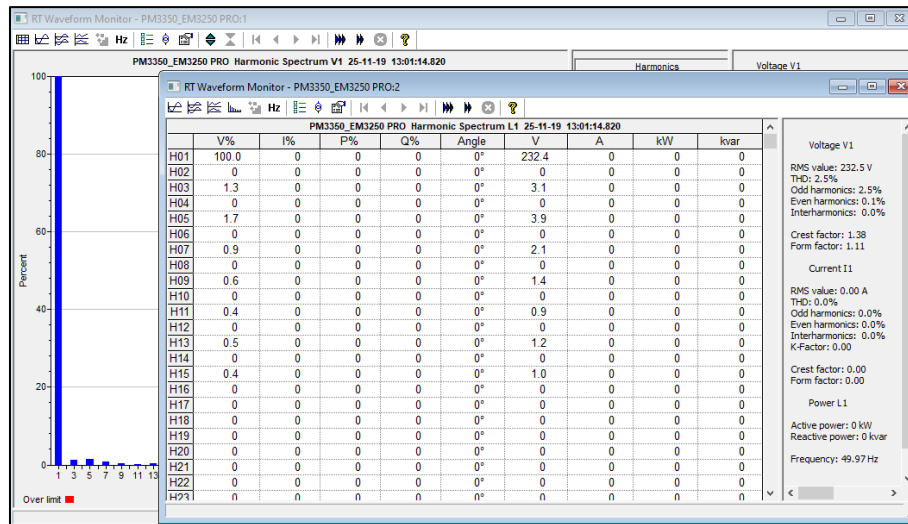



Figure 15-8 RT Harmonic Monitor – Spectrum Table

## Viewing Synthesized Waveforms

To view the synthesized waveforms based on the sampled harmonic spectrum, click on the  button on the local toolbar to view non-overlapped voltage and current waveforms, or click on the  button to view them overlapped.

PAS shows a pair of 4-cycle voltage and current synthesized AC waveforms for a single phase.

To select the channels you want to view, click with the right mouse button on the waveform window, select “Channels...”, check the channels for the phase you want displayed, and then click OK.

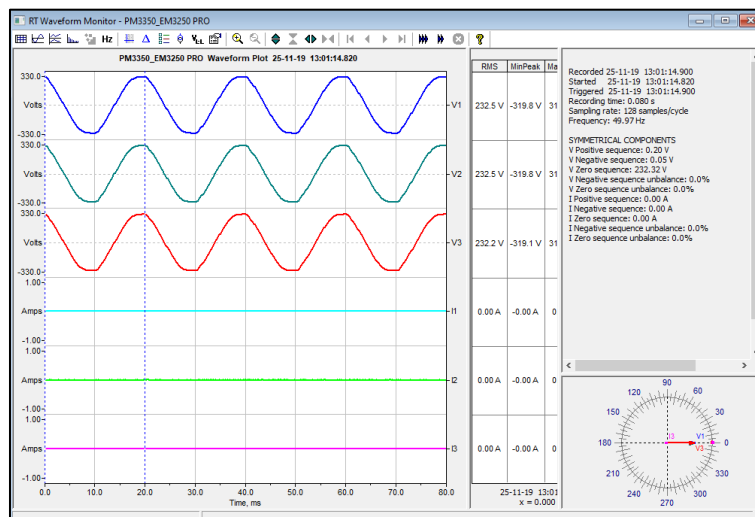

Figure 15-9 RT Harmonic Monitor – Synthesized Waveforms

## Chapter 16 Retrieving and Storing Files

Using PAS, you can retrieve recorded events, data and waveforms from your devices and save them to files on your PC in the MS Access database format.

Historical data can be uploaded on demand any time you need it, or periodically through the Upload Scheduler that retrieves data automatically on a predefined schedule, for example, daily, weekly or monthly. If you do not change the destination database location, the new data is added to the same database so you can store long-term data profiles in one database regardless of the upload schedule you selected.

### 16.1.1 Uploading Files on Demand

To retrieve the log files from your device:

1. Select a device site from the list box on the PAS toolbar.
2. Check the On-line button .
3. Select Upload Logs from the Logs menu.
4. Select a database, or type the name for a new database, and select a directory where you want to save it.

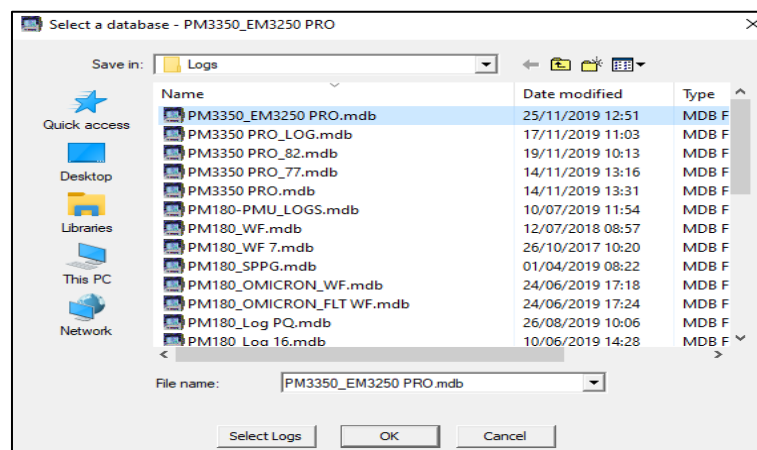

Figure 16-1

5. Click on the “Select Logs” button and check boxes for logs you want to be retrieved from the device.

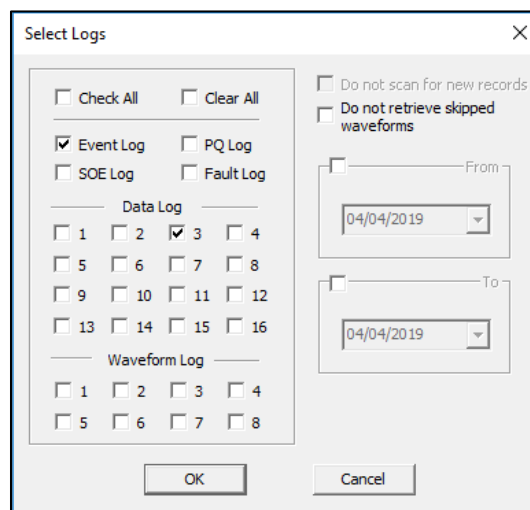



Figure 16-2

6. If you wish to retrieve data starting with a known date, check the “From” box and select the start date for retrieving data.
7. If you wish to retrieve data recorded before a known date, check the “To” box and select the last date for retrieving data.



6. Select the number of attempts to upload data in the event of temporary communication problems or unavailability of your device, and the delay between attempts in minutes and seconds.
7. If you wish to use the schedule to synchronize the device clock with your PC, check the "RTC Synchronization Enable" box. If your device is password protected by a communications password, type in the password you set in the device to allow PAS to update the clock.
8. Click on the Select Logs button, check the boxes for logs you want to upload on a schedule, and then click OK.
9. Check the Enabled box at left to activate a schedule for the device.
10. Click OK to store your schedule.

To keep the Upload Scheduler running, the On-line button  on the PAS toolbar must be checked all the time. If you uncheck it, the scheduler stops operations. This does not cause loss of data, since the scheduler will resume operations when you check this button again.

## Suspending the Scheduler

To suspend the Upload Scheduler, check the Suspend Scheduler box at right. To activate the Upload Scheduler, leave this box unchecked.

## Running the Scheduler on Demand

You can run the scheduler at any time outside the schedule by checking the Start Now box at right. This is a one-time action. After uploading is completed, the Upload Scheduler un-checks this box automatically.

## Reviewing Upload Problems

When the Upload Scheduler fails to retrieve data from the device, or some data is missing, or another problem occurs, it puts an error message to the log file. To review this file, select System Log from the View menu.

## Chapter 17 Viewing Log Files



### 17.1 General Operations

#### 17.1.1 Opening a Log File

To open a log file, click on the Open button  on the PAS toolbar, or select “Open...” from the File menu. In the “Files of type” box, select “Access Database (\*.mdb)”, select a directory where your files are located, point to the file you want to open, select a desired table on the right pane, and then click Open.

#### 17.1.2 Copying Data

To copy the entire data table or graph, or part of the data, into the Clipboard or into another application such as Microsoft Excel or Word:

1. Click on the data window with the right mouse button and choose Select All, or, if your current view represents a table, click on the upper-left corner of the table (where the “No.” label is commonly displayed).
2. Click with the right mouse button on the window again and choose Copy, or click on the Copy button  on the PAS toolbar.
3. Run the application to which you want to copy data, position the cursor at the correct place, and then click the Paste button  on the application's toolbar or select Paste from the Edit menu.

#### 17.1.3 Saving Data to a File

To save data to a file, click on the Save button , select a directory where you want your log file to be stored, select a database or type the name for a new database, and then click Save. To avoid confusion, do not store data files into the “Sites” directory where site databases are located.

#### 17.1.4 Printing Reports

To print a data report to a printer, click on the print button  on the toolbar, select a printer and click OK. If you want to check how your document appears on the printed page, select Print Preview from the File menu.

#### 17.1.5 Customizing Views

##### Date Order

To change the way PAS displays the date, select Options from the Tools menu, click on the Preferences tab, select the preferred date order, and then click OK.

##### Timestamp

The timestamp is normally recorded and displayed on the screen at a 1-ms resolution. If you have an application that does not support this format, you may instruct PAS to drop the milliseconds. To change the way PAS records and displays the timestamp, select Options from the Tools menu, click on the Preferences tab, select the preferred timestamp format, and then click OK.

##### Voltage Disturbance Units

When programming a voltage disturbance trigger in your device, the operate limit for the trigger can be set either in a percent of the nominal voltage, or in voltage RMS units. To change the disturbance units, select Options from the Tools menu, click on the Preferences tab, select the preferred units, and then click OK.

### 17.2 Viewing Options

#### 17.2.1 Customizing Views

## Changing Date Order

To change the way PAS displays the date:

1. Select Options from the Tools menu and click on the Preferences tab.
2. Select the preferred date order.
3. Click OK.

## Selecting Timestamp Format

The timestamp is normally recorded and displayed on the screen at a 1-ms resolution. If you have an application that does not support this format, you may instruct PAS to drop milliseconds.

To change the way PAS records and displays the timestamp:

1. Select Options from the Tools menu and click on the Preferences tab.
2. Select the preferred timestamp format.
3. Click OK.

## 17.2.2 Working with Tables

### Selecting Font and Grid

To change the table font or a type of the grid lines:

1. Click with right mouse button on the table, select Options and click on the Table tab.
2. Select the font type and size and how you wish the table grid to be shown.
3. Click OK.



### Selecting Primary and Secondary Units

Voltages and currents can be displayed in primary or secondary units.

To change units, click on the table with the right mouse button, select Options, select the desired units for voltages and currents, and then click OK.

### Copying a Table

To copy the entire table, or its part, into the Clipboard or into another application such as Microsoft Excel or Word:

1. Click on the data window with the right mouse button and choose Select All, or click on the upper-left corner of the table (where the "No." label is commonly displayed).
2. Click with the right mouse button on the window again and choose Copy, or click on the Copy button  on the PAS toolbar.
3. Run the application to which you want to copy data, position the cursor at the correct place.
4. Click the Paste button  on the application's toolbar or select Paste from the Edit menu.

When copying, table columns are separated by a tab character.

### Printing a Table

To check how your document appears on a printed page, select Print Preview from the File menu.

To print a table to a printer, click on the print button  on the toolbar, select a printer and click OK.

## 17.2.3 Working with Graphic Windows

### Selecting Channels

To select the channels, you want to view on the screen, click on the graph window with the right mouse button, select Channels..., check the channels you want displayed, and then click OK.

Checkboxes for channels that are not available in the present view are dimmed.

## Selecting Primary and Secondary Units

Voltages and currents can be displayed in primary or secondary units.

To change units, click on the table with the right mouse button, select Options, select the desired units for voltages and currents, and then click OK.

## Selecting the Time Axis

In waveform views, the horizontal axis can be displayed either in absolute time with date and time stamps, or in milliseconds relatively to the beginning of a waveform.

To change the time units, click on the waveform window with the right mouse button, select Options..., click on the Axes tab, select the desired units, and then click OK.

## Selecting Line Styles and Colors

Channel waveforms can be displayed using different colors and line styles.

To change the colors or line styles, click on the graph window with the right mouse button, select Options..., click on the Display tab, adjust colors and styles, and then click OK.

## Selecting Grid and Frame Colors

Click on the graph window with the right mouse button, select Options..., and click on the Display tab

To change the color or style of the grid lines, click on the Grid line on the left pane, and then select the color and style for the grid. To disable the grid, uncheck the Grid Visible box.

To change the window frame color to white, check the White Frame box at right.

## Using Marker Lines

The waveform and trend windows have two blue dashed marker lines. The left marker indicates the starting position and the right marker indicates the end position for calculating the average and peak values.

The minimum distance between the two markers is exactly one cycle.

To change the marker position, click on the  button, or click on the window with the right mouse button and select Set Marker, and then click on the point where you want to put the marker.

You can also drag both markers with the mouse, or use the right and left arrow keys on your keyboard to change the marker position. Click on the graph pane to allow the keyboard to get your input before using the keyboard.

## Delta Measurements



To measure the distance between two waveform or trend points, click on the Delta button , then click on the first point, and then click on the second point.

The first reference point is still frozen until you uncheck and check the Delta button again, while the second point can be placed anywhere within the graph line by clicking on the graph to the left or right from the reference point.

To disable delta measurements, click on the Delta button once again.

## Using a Zoom

You can use a horizontal and, for waveforms, also a vertical, zoom to change size of your graph.

Use the  buttons on your local toolbar to zoom in and zoom out. One click gives you a 100-percent horizontal or 50-percent vertical zoom. Two buttons  representing magnifying glasses give you a proportional zoom in both directions.

## Copying a Graph

To copy a graph, or its part, into the Clipboard or into another application such as Microsoft Excel or Word:

1. Click on the graph window with the right mouse button and choose Copy All, or Copy Waveform. Some windows may have additional options.
2. Position the cursor at the place where you wish to copy the graph.
3. Click the Paste button  on the application's toolbar or select Paste from the Edit menu.

## Printing a Graph

To check how the graph appears on a printed page, select Print Preview from the File menu.

To print a graph to a printer, click on the Print button  on the PAS toolbar, select a printer and click OK.

## 17.3 Viewing the Event Log

Event log files are displayed in a tabular view, one event per row. PAS loads the entire database table to a window, so that you can scroll through the entire log to view its contents.

No.	Date/Time	Event	Cause	Point/Source	Value	Effect
83	17-11-19 10:58:59.729	EV:35	COMM	Net setup		Setup change
84	17-11-19 10:59:02.825	EV:36	EXTERNAL	Device reset		
85	17-11-19 11:00:06.640	EV:37	COMM	Net setup		Setup change
86	17-11-19 11:00:09.740	EV:38	EXTERNAL	Device reset		
87	17-11-19 11:00:17.521	EV:39	COMM	Net setup		Setup change
88	17-11-19 11:00:29.004	EV:1	SELF-CHECK	Data memory		Cleared Min/Max
89	17-11-19 11:00:29.004	EV:2	SELF-CHECK	Data memory		Cleared max dmd
90	17-11-19 11:00:29.005	EV:3	SELF-CHECK	Data memory		Cleared TOU max dmd
91	17-11-19 11:01:20.000	EV:5	EXTERNAL	Power down		
92	17-11-19 11:01:53.094	EV:4	COMM	Net setup		Setup change
93	17-11-19 11:01:56.178	EV:5	EXTERNAL	Device reset		
94	17-11-19 11:02:49.000	EV:6	EXTERNAL	Power up		
95	18-11-19 06:54:00.000	EV:17	EXTERNAL	Power down		
96	18-11-19 13:20:51.074	EV:14	EXTERNAL	Power down		
97	18-11-19 13:24:24.000	EV:15	EXTERNAL	Power up		
98	18-11-19 13:25:06.920	EV:16	COMM	Setpoints setup		SP disabled
99	18-11-19 13:35:26.972	EV:17	COMM	RTC	18-11-19 13:29:14	RTC set
100	19-11-19 11:20:15.621	EV:18	EXTERNAL	Device reset		
101	21-11-19 08:48:45.878	EV:19	EXTERNAL	Device reset		
102	21-11-19 08:53:12.998	EV:20	EXTERNAL	Device reset		
103	21-11-19 08:55:54.038	EV:21	COMM	Diagnostics		Cleared
104	24-11-19 11:06:27.000	EV:18	EXTERNAL	Power up		
105	24-11-19 17:11:58.172	EV:21	EXTERNAL	CPU WDT reset		
106	24-11-19 17:12:44.131	EV:22	EXTERNAL	Device reset		
107	25-11-19 09:58:08.393	EV:23	COMM	Counters setup		Setup change
108	25-11-19 09:58:08.682	EV:24	COMM	Counters setup		Setup change
109	25-11-19 12:50:10.340	EV:25	EXTERNAL	Device reset		

Figure 17-1

### Selecting Primary and Secondary Units

Voltages and currents can be displayed in primary or secondary units. To select units for your data views, click on the monitor window with the right mouse button, select Options, select the desired units for voltages and currents, and then click OK.

#### Filtering and Sorting Events

You can use filtering to find and work with a subset of events that meet the criteria you specify. Click on the Filter button , or click on the report window with the right mouse button and select "Filter...". Check the causes of events you want to display, and then click OK. PAS temporarily hides rows you do not want displayed.

To change the default sorting order based on the date and time, click on the Sort button , or click on the report window with the right mouse button and select "Sort...", check the desired sort order, and then click OK.

#### Linking to Waveforms and Data Records

If you programmed a setpoints to log setpoints operations to the Event log and the setpoints can trigger the Waveform or Data recorder, PAS automatically establishes links between the event and other database records where it finds a relationship with the event. Waveforms recorded at the time of the event are always linked to this event, even if the waveform was triggered by another source.

The event ID for which PAS finds related data is blue colored. Click on the colored event ID to check a list of the event links. Click on a list item to move to the related waveform or data log record.

## 17.4 Viewing the Power Quality Log

### 17.4.1 Viewing the Power Quality Log

PQ log files are displayed in a tabular view, one event per row.

No.	Date/Time	Event	Fault Category	Phase	Fault Magnitude	PU
1	13-11-19 15:31:44.000	PQE7:3067	Frequency variation		49.95	0.833
2	13-11-19 15:48:17.079	PQE33:3068	Overvoltage	V1	233.2	1.01
3	13-11-19 15:55:59.651			V1	234.6	1.02
4	13-11-19 15:55:59.651			V2	234.5	1.02
5	13-11-19 15:55:59.651	PQE33:3071	Overvoltage	V3	234.3	1.01
6	13-11-19 15:58:15.000	PQE7:3072	Frequency variation		50.05	1.001
7	13-11-19 15:59:33.000	PQE7:3073	Frequency variation		50.07	1.001
8	13-11-19 16:42:34.407	PQE33:3076	Overvoltage	V1	234.2	1.01
9	13-11-19 16:42:34.407	PQE33:3076	Overvoltage	V2	234.2	1.01
10	13-11-19 16:42:34.407	PQE33:3076	Overvoltage	V3	234.0	1.01
11	13-11-19 16:51:21.996	PQE33:3075	Overvoltage	V1	233.5	1.01
12	13-11-19 16:51:21.996	PQE33:3075	Overvoltage	V2	233.5	1.01
13	13-11-19 16:51:21.996	PQE33:3075	Overvoltage	V3	233.3	1.01
14	13-11-19 16:51:39.000	PQE7:3076	Frequency variation		49.94	0.999
15	13-11-19 16:51:48.000	PQE7:3077	Frequency variation		49.95	0.999
16	13-11-19 16:54:24.404	PQE33:1	Overvoltage	V1	233.6	1.01
17	13-11-19 16:54:24.404	PQE33:1	Overvoltage	V2	233.6	1.01
18	13-11-19 16:54:24.404	PQE33:1	Overvoltage	V3	233.4	1.01
19	13-11-19 17:00:08.687	PQE33:3	Overvoltage	V1	233.7	1.01
20	13-11-19 17:00:08.687	PQE33:3	Overvoltage	V2	233.7	1.01
21	13-11-19 17:00:08.687	PQE33:3	Overvoltage	V3	233.5	1.01
22	13-11-19 17:00:24.000	PQE7:4	Frequency variation		50.06	1.001
23	13-11-19 17:02:12.000	PQE7:5	Frequency variation		49.95	0.999
24	13-11-19 17:33:12.000	PQE7:8	Frequency variation		49.94	0.999
25	13-11-19 17:33:21.000	PQE7:9	Frequency variation		49.95	0.999
26	13-11-19 19:08:33.000	PQE7:10	Frequency variation		50.06	1.001
27	14-11-19 08:42:39.000	PQE7:11	Frequency variation		49.95	0.999

Figure 17-2

### Selecting Primary and Secondary Units

Voltages and currents can be displayed in primary or secondary units. To select units for your report, click on the report window with the right mouse button, select Options, select the desired units for voltages and currents, and then click OK.

### Filtering and Sorting Events

To filter events, click on the Filter button , or click on the report window with the right mouse button and select "Filter...", check the categories of events you want to display, and then click OK.

To change the default event sorting order, click on the Sort button , or click on the report window with the right mouse button and select "Sort...", check the desired sort order, and then click OK.

No.	Date/Time	Event	Fault Category	Phase	Fault Magnitude	PU
8253	01-12-19 12:24:07.510	PQE11:935	Impulsive transient	V1	84.1	0.2
8254	01-12-19 12:24:22.401	PQE212:941	Swell, instantaneous			1.0
8255	01-12-19 12:24:22.401	PQE212:941	Swell, instantaneous			1.0
8256	01-12-19 12:24:22.401	PQE212:941	Swell, instantaneous			1.0
8257	01-12-19 12:24:38.402	PQE33:943	Overvoltage			1.0
8258	01-12-19 12:24:38.402	PQE33:943	Overvoltage			1.0
8259	01-12-19 12:24:38.402	PQE33:943	Overvoltage			1.0
8260	01-12-19 14:01:23.404	PQE33:945	Overvoltage			1.0
8261	01-12-19 14:01:23.404	PQE33:945	Overvoltage			1.0
8262	01-12-19 14:01:23.404	PQE33:945	Overvoltage			1.0
8263	02-12-19 03:04:55.386	PQE211:946	Sag, instantaneous			0.9
8264	02-12-19 03:04:55.386	PQE211:946	Sag, instantaneous			0.9
8265	02-12-19 03:04:55.386	PQE211:946	Sag, instantaneous			0.9
8266	02-12-19 03:04:57.036	PQE211:947	Sag, instantaneous			0.9
8267	02-12-19 03:04:57.036	PQE211:947	Sag, instantaneous			0.9
8268	02-12-19 03:04:57.036	PQE211:947	Sag, instantaneous			0.9
8269	02-12-19 07:40:28.434	PQE32:948	Undervoltage			0.9
8270	02-12-19 07:40:28.434	PQE32:948	Undervoltage			0.9
8271	02-12-19 07:40:28.434	PQE32:948	Undervoltage			0.9
8272	02-12-19 07:41:03.598	PQE11:949	Impulsive transient			0.3
8273	02-12-19 07:41:03.598	PQE11:949	Impulsive transient			0.3
8274	02-12-19 07:41:03.598	PQE11:949	Impulsive transient			0.3
8275	02-12-19 09:23:47.544	PQE11:952	Impulsive transient			0.3
8276	02-12-19 09:23:51.200	PQE11:954	Impulsive transient			0.2
8277	02-12-19 09:23:51.603	PQE11:955	Impulsive transient			0.2
8278	02-12-19 09:23:52.099	PQE11:956	Impulsive transient			0.2
8279	02-12-19 09:23:52.162	PQE11:957	Impulsive transient			0.2

Figure 17-3

## Linking to Waveforms and Data Records

PQ events for which PAS finds related links are blue colored. Click on the colored event ID to check a list of the event links. Click on a list item to move to the related waveform or data log records. Data log records associated with the event are taken into a separate window for easy viewing and trending.

## Retrieving Waveforms Online

If you programmed the PQ recorder to record waveforms on power quality events, you can upload the waveforms related to a specific event online if they have not yet been retrieved and stored to the database on your PC. Events for which PAS did not find a corresponding waveform in the database are still black colored. Click on the event ID, click on the “Retrieve Waveform” prompt, and then point to a database to which you want the waveform to be stored.

## 17.4.2 Viewing the ITI (CBEMA) Curve

Impulsive transients and short-duration voltage variations (sags and swells) can be viewed as magnitude/duration pairs on the ITIC (the Information Technology Industry Council, formerly CBEMA) curve chart. To view an ITI curve chart, click on the “ITI” button on the window toolbar.

To view the event details, click on the event point with the left mouse button. To directly move to the related power quality report entry or to a waveform record, click on the corresponding list item with the left mouse button.

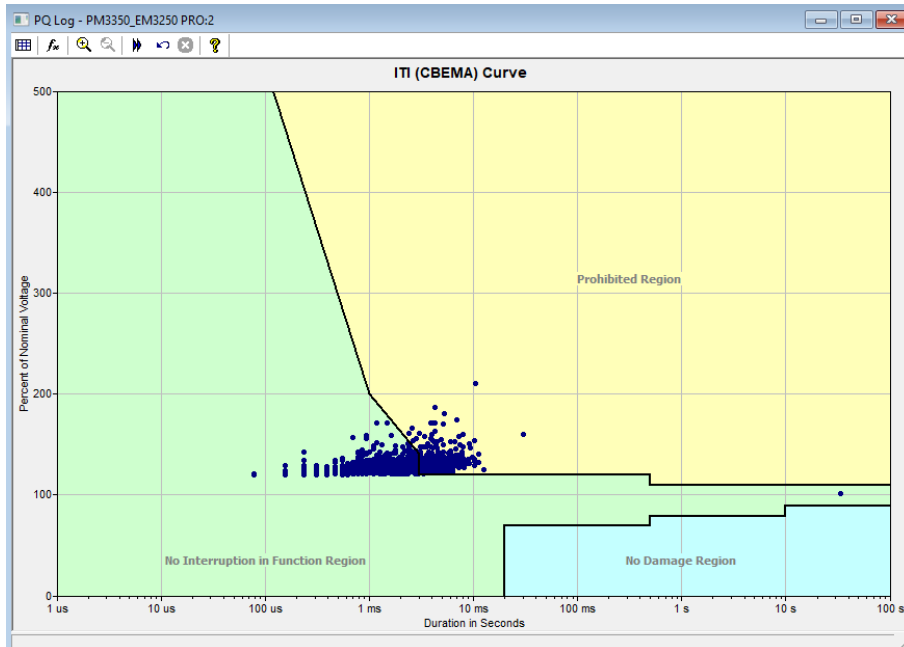
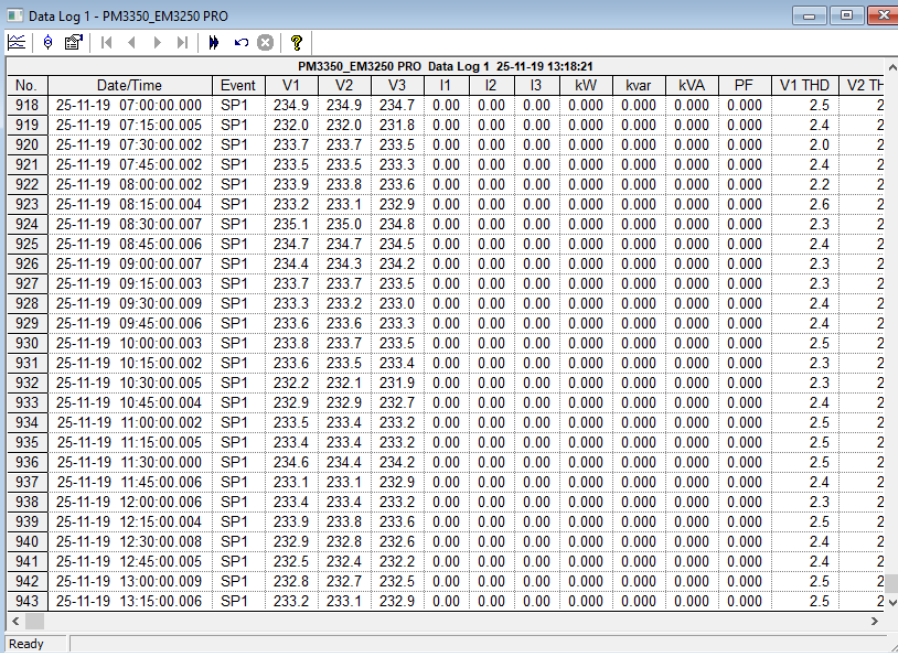

Figure 17-4

## 17.5 Viewing the Data Log

Data log files can be displayed in a tabular view, one data record per row, or in a graphical view as a data trend graph.



The screenshot shows a window titled "Data Log 1 - PM3350\_EM3250 PRO" with a toolbar and a table of data records. The table has the following columns: No, Date/Time, Event, V1, V2, V3, I1, I2, I3, kW, kvar, kVA, PF, V1 THD, and V2 THD. The data records range from No. 918 to 943, with dates and times from 25-11-19 07:00:00.000 to 25-11-19 13:15:00.006. The events are all "SP1". The voltage (V1-V3) and current (I1-I3) values are relatively stable, while the power (kW, kvar, kVA) and power factor (PF) values are mostly 0.000. The THD values are around 2.0 to 2.5.

No	Date/Time	Event	V1	V2	V3	I1	I2	I3	kW	kvar	kVA	PF	V1 THD	V2 THD
918	25-11-19 07:00:00.000	SP1	234.9	234.9	234.7	0.00	0.00	0.00	0.000	0.000	0.000	0.000	2.5	2
919	25-11-19 07:15:00.005	SP1	232.0	232.0	231.8	0.00	0.00	0.00	0.000	0.000	0.000	0.000	2.4	2
920	25-11-19 07:30:00.002	SP1	233.7	233.7	233.5	0.00	0.00	0.00	0.000	0.000	0.000	0.000	2.0	2
921	25-11-19 07:45:00.002	SP1	233.5	233.5	233.3	0.00	0.00	0.00	0.000	0.000	0.000	0.000	2.4	2
922	25-11-19 08:00:00.002	SP1	233.9	233.8	233.6	0.00	0.00	0.00	0.000	0.000	0.000	0.000	2.2	2
923	25-11-19 08:15:00.004	SP1	233.2	233.1	232.9	0.00	0.00	0.00	0.000	0.000	0.000	0.000	2.6	2
924	25-11-19 08:30:00.007	SP1	235.1	235.0	234.8	0.00	0.00	0.00	0.000	0.000	0.000	0.000	2.3	2
925	25-11-19 08:45:00.006	SP1	234.7	234.7	234.5	0.00	0.00	0.00	0.000	0.000	0.000	0.000	2.4	2
926	25-11-19 09:00:00.007	SP1	234.4	234.3	234.2	0.00	0.00	0.00	0.000	0.000	0.000	0.000	2.3	2
927	25-11-19 09:15:00.003	SP1	233.7	233.7	233.5	0.00	0.00	0.00	0.000	0.000	0.000	0.000	2.3	2
928	25-11-19 09:30:00.009	SP1	233.3	233.2	233.0	0.00	0.00	0.00	0.000	0.000	0.000	0.000	2.4	2
929	25-11-19 09:45:00.006	SP1	233.6	233.6	233.3	0.00	0.00	0.00	0.000	0.000	0.000	0.000	2.4	2
930	25-11-19 10:00:00.003	SP1	233.8	233.7	233.5	0.00	0.00	0.00	0.000	0.000	0.000	0.000	2.5	2
931	25-11-19 10:15:00.002	SP1	233.6	233.5	233.4	0.00	0.00	0.00	0.000	0.000	0.000	0.000	2.3	2
932	25-11-19 10:30:00.005	SP1	232.2	232.1	231.9	0.00	0.00	0.00	0.000	0.000	0.000	0.000	2.3	2
933	25-11-19 10:45:00.004	SP1	232.9	232.9	232.7	0.00	0.00	0.00	0.000	0.000	0.000	0.000	2.4	2
934	25-11-19 11:00:00.002	SP1	233.5	233.4	233.2	0.00	0.00	0.00	0.000	0.000	0.000	0.000	2.5	2
935	25-11-19 11:15:00.005	SP1	233.4	233.4	233.2	0.00	0.00	0.00	0.000	0.000	0.000	0.000	2.5	2
936	25-11-19 11:30:00.000	SP1	234.6	234.4	234.2	0.00	0.00	0.00	0.000	0.000	0.000	0.000	2.5	2
937	25-11-19 11:45:00.006	SP1	233.1	233.1	232.9	0.00	0.00	0.00	0.000	0.000	0.000	0.000	2.4	2
938	25-11-19 12:00:00.006	SP1	233.4	233.4	233.2	0.00	0.00	0.00	0.000	0.000	0.000	0.000	2.3	2
939	25-11-19 12:15:00.004	SP1	233.9	233.8	233.6	0.00	0.00	0.00	0.000	0.000	0.000	0.000	2.5	2
940	25-11-19 12:30:00.008	SP1	232.9	232.8	232.6	0.00	0.00	0.00	0.000	0.000	0.000	0.000	2.4	2
941	25-11-19 12:45:00.005	SP1	232.5	232.4	232.2	0.00	0.00	0.00	0.000	0.000	0.000	0.000	2.4	2
942	25-11-19 13:00:00.009	SP1	232.8	232.7	232.5	0.00	0.00	0.00	0.000	0.000	0.000	0.000	2.5	2
943	25-11-19 13:15:00.006	SP1	233.2	233.1	232.9	0.00	0.00	0.00	0.000	0.000	0.000	0.000	2.5	2

Figure 17-2

### 17.5.1 Viewing Data Trend

To view data in a graphical form, click on the Data Trend  button on the local toolbar.

To change the time range for your graph, click on the Time Range button  on the local toolbar, and then select the desired date and time range.

#### Selecting Channels

To select desired data channels for your trend, click on the trend window with the right mouse button, select "Channels", check the channels you want displayed, and then click OK.

#### Customizing Line Colors and Styles

Trend lines for different channels can be shown in different colors using different line styles. To change the colors or line styles, click on the trend window with the right mouse button, select "Options...", click on the "Display" tab, adjust colors and styles for channels, and then click OK. You can also change the colors for the background and gridlines.

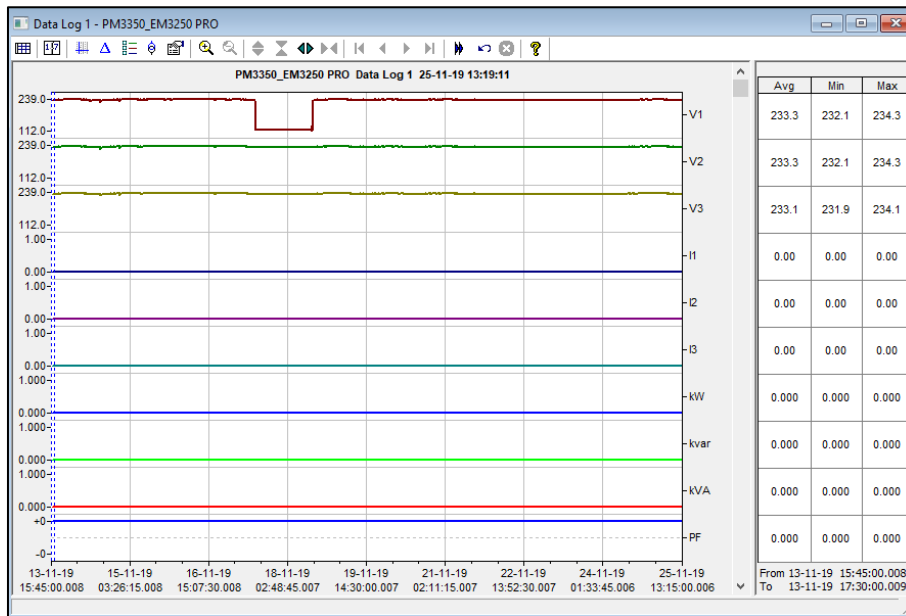





Figure 17-3

## Using the Marker Lines

The trend window has two blue dashed marker lines. The left marker indicates the starting position and the right marker indicates the end position for calculating the average and peak values.

To change the marker position, click on the trend window with the right mouse button, select Set Marker, or click on the  button on the window toolbar, and then click with left mouse button on the point where you want to put the marker. You can also drag both markers with the mouse, or use the right and left arrow keys on your keyboard to change the marker position (click on the trend pane with the mouse before using the keyboard, to allow the keyboard to receive your input).

## Using a Zoom

You can use a horizontal and a vertical zoom to change size of your graph. Use the  buttons on your local toolbar representing green arrowheads to zoom in and zoom out. One click gives you a 100-percent horizontal zoom. Two buttons  representing magnifying glasses give you a proportional zoom in both directions.

## Delta Measurements

To measure the distance between two trend points, click on the Delta button , then click on the first point, and then click on the second point. The first reference point is still frozen until you close and reopen Delta, while the second point can be placed anywhere within the trend line. You can measure a delta in both directions. To disable delta measurements, click on the Delta button once again.

## 17.6 Viewing Waveforms

Waveform data can be displayed in five different views. When you open a new file, PAS shows you a waveform graph showing non-overlapped waveforms. Each waveform window has a local toolbar from where you can open another window to examine the waveform in a different view.

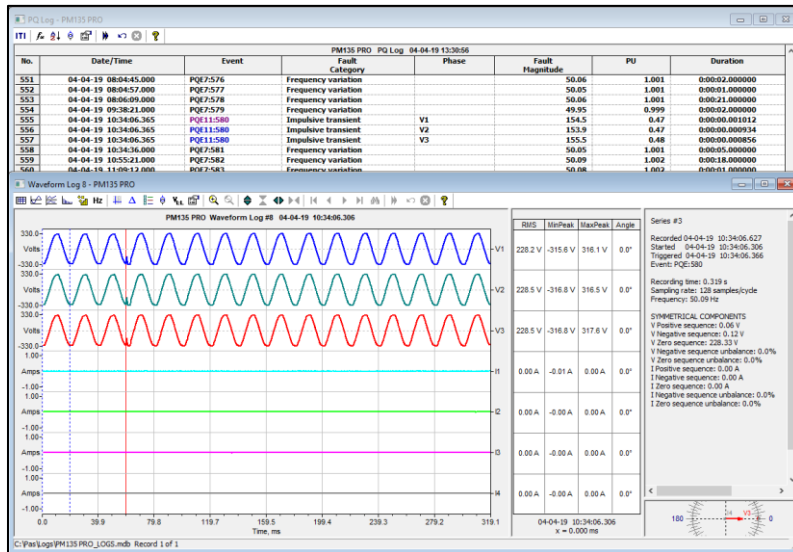

Figure 17-4

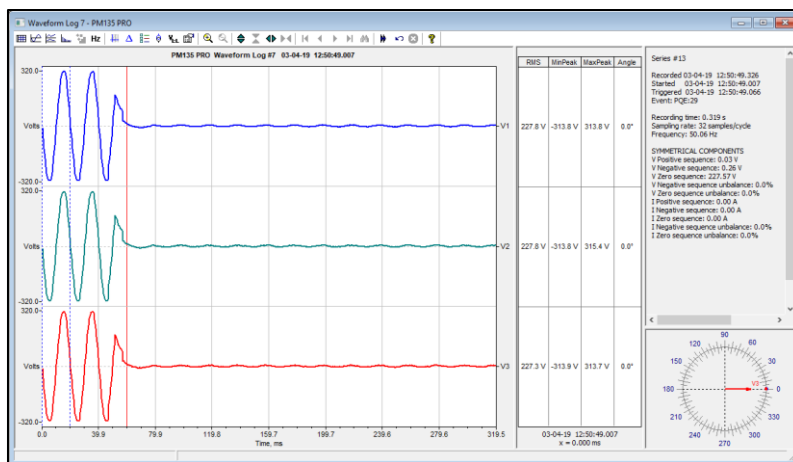





Figure 17-5

You can open all five views together to analyze different properties of the waveform like a wave shape, waveform disturbance, unbalance, or spectrum. When you move to another waveform record, all views are updated simultaneously to reflect the changes.

To view overlapped waveforms, click on the  button on the local toolbar; to view non-overlapped waveforms, click on the  button.

Waveform data is recorded in series that may contain many cycles of the sampled waveform. A waveform window displays up to 128 waveform cycles. If the waveform contains more cycles, the scroll bar appears under the waveform pane allowing you to scroll through the entire waveform.

### 17.6.1 Viewing an RMS Plot

PAS can show you a cycle-by-cycle RMS plot of the sampled AC waveforms. To open the RMS view, click on the  button. The graph shows the RMS points updated each half cycle.

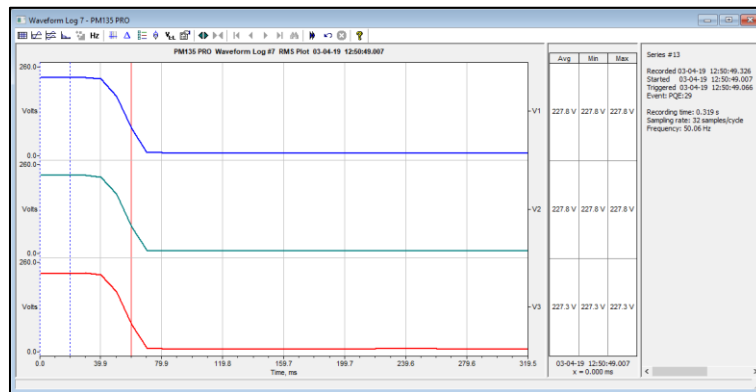



Figure 17-6

### 17.6.2 Viewing a Frequency Plot

To view a cycle-by-cycle frequency plot of the sampled voltage waveforms, click on the  button.

### 17.6.3 Viewing a Spectrum Chart

Click on the  button to view a spectrum chart for the selected waveform channel. To change a channel, click on the window with the right mouse button, select “Channels...”, check the channel you want displayed, and then click OK. PAS provides voltage, current, active power and reactive power spectrum charts.

A spectrum is calculated over four cycles of the waveform beginning from the point where the left marker line is located in the open waveform view. If both waveform views are open, PAS gives the priority to the overlapped waveform view.

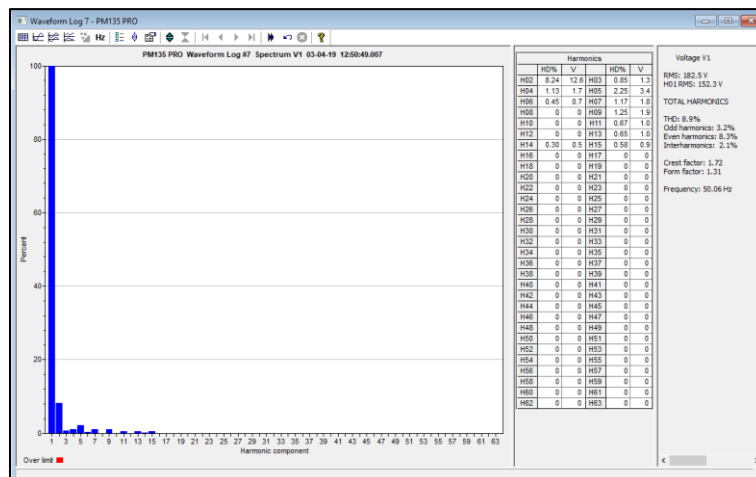

Figure 17-7

The order of the highest displayed harmonic component is equal to the half sampling rate at which the waveforms are sampled minus one. If the waveform was sampled at a rate of 256 samples per cycle, 63 harmonics are available. With 32 samples per cycle, only 15 harmonics are calculated, while others will be zeros.

PAS can give you indication on whether harmonic levels in the sampled waveforms exceed compliance limits defined by the power quality standards or local regulations.

To review or change harmonic limits:

1. Click on the spectrum window with the right mouse button and select “Limits...”.
  2. Select a harmonics standard, or select “Custom” and specify your own harmonic limits.
  3. Check the Enabled box to visualize harmonic faults on the spectrum graph and in harmonic tables.
- Harmonics that exceed selected compliance levels are colored in red on the graph and in the tables.



Figure 17-8

### 17.6.4 Viewing a Spectrum Table

Click on the  button on the local toolbar to display the harmonics spectrum in a tabular view for a selected phase or for all phases together.

The spectrum table shows voltage, current, active power and reactive power harmonic components both in percent of the fundamental and in natural units, and harmonic phase angles.

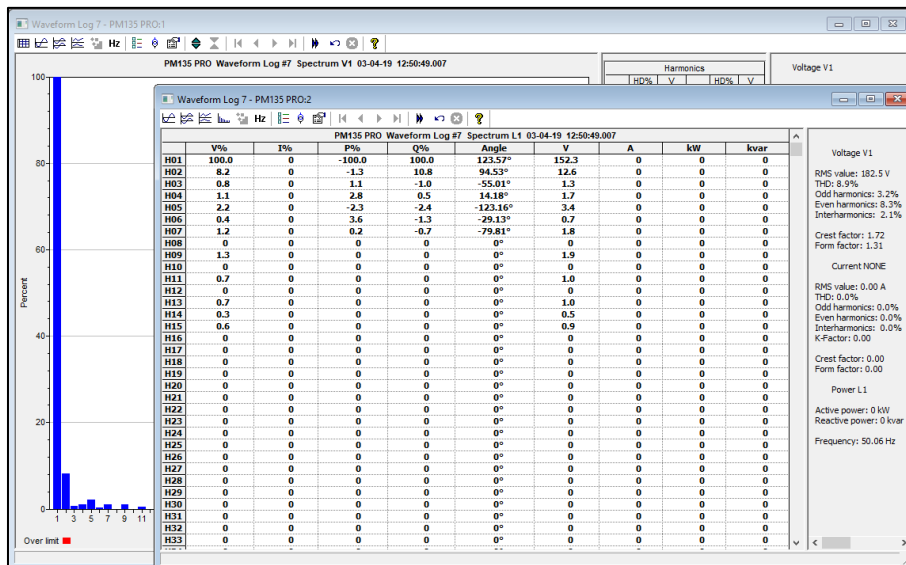



Figure 17-9

To change a phase, click on the window with the right mouse button, select “Options...”, check the phase you want displayed, and then click OK.

### 17.6.5 Waveform Options

## Scrolling through Waveforms

The status bar at the bottom of the window shows you how many records the log file contains. Use green arrowheads  on the window toolbar to scroll through records.

## Selecting Waveform Channels

A single waveform record may contain up to 33 waveforms including AC, digital and analog input channels, which can be displayed all together in a non-overlapped waveform view.

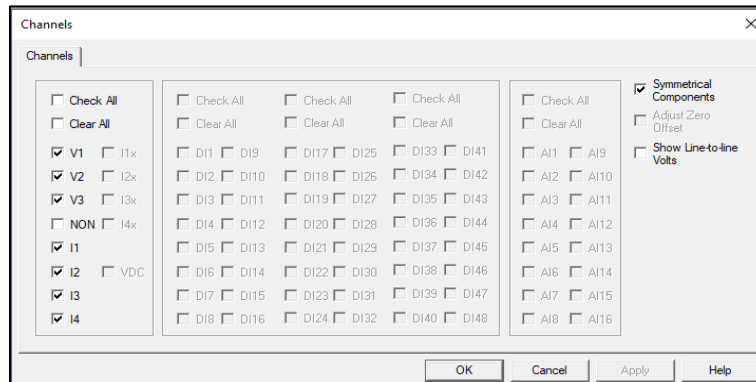

Figure 17-10

To select the channels, you want to view on the screen, click on the waveform window with the right mouse button, select “Channels...”, check the channels you want displayed, and then click OK.

Checkboxes for channels that are not present in the waveform are dimmed.

## Selecting the Time Axis

The horizontal axis can be displayed either in absolute time with date and time stamps, or in milliseconds relatively to the beginning of a waveform. To change the time units, click on the waveform window with the right mouse button, select “Options...”, click on the “Axes” tab, select the desired units, and then click OK.

## Customizing Line Colors and Styles

Channel waveforms are displayed using different colors and line styles. To change the colors or line styles, click on the waveform window with the right mouse button, select “Options...”, click on the Display tab, adjust colors and styles, and then click OK. You can also change the waveform background and gridlines color.

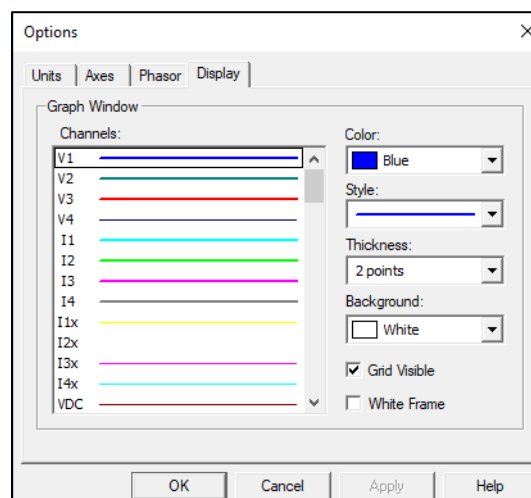

Figure 17-11

## Viewing Phasor Diagrams

The phasor diagrams show you the relative magnitudes and angles of the three-phase voltage and current fundamental component. All angles are shown relative to the reference voltage channel.

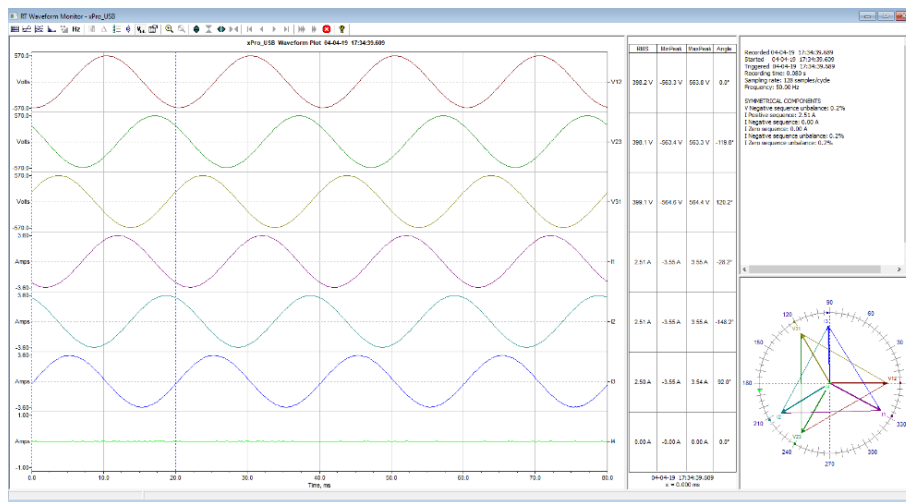

Figure 17-12

To change the reference channel, click on the waveform window with the right mouse button, select “Options...”, click on the “Phasor” tab, check the channel you want to make a reference channel, and then click “OK”.

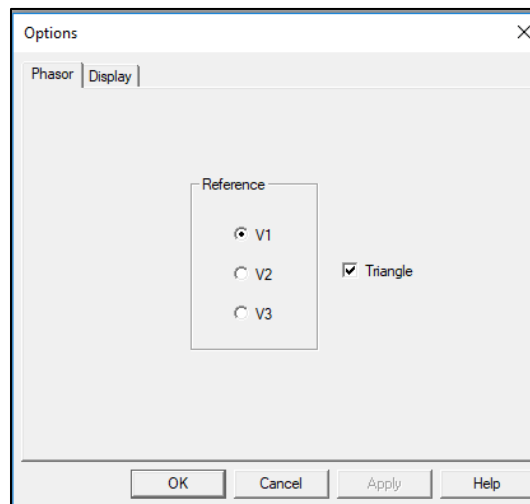

Figure 17-13

If you leave the Triangle box checked, PAS connects the ends of the voltage and current vectors showing you three-phase voltage and current triangles. This is useful when analyzing voltage and current unbalances.

Phasor diagrams are calculated over one waveform cycle pointed to by the left marker line. As you move the marker, the phasor diagrams are updated reflecting the new marker position.

## Viewing Symmetrical Components

Waveform views have an additional pane at the right where PAS displays the symmetrical components for voltages and currents, calculated for the point indicated by the left marker line. To enable or disable the symmetrical components, click on the waveform window with the right mouse button, select “Options...”, check or uncheck the “Symmetrical components” box on the “Channels” tab, and then click OK.

## Selecting Primary and Secondary Units



Voltages and currents can be displayed in primary or secondary units. To select units for your waveforms, click on the waveform window with the right mouse button, select "Options...", select the desired units for voltages and currents on the Channels tab, and then click OK.

## Using the Marker Lines

Waveform and RMS panes have two blue dashed marker lines. The left marker indicates the position from where data is taken to calculate the harmonics spectrum and phasor diagrams, and also as the starting position for calculating the RMS, average and peak values. The right marker indicates the end position for calculating the RMS, average and peak values. The minimum distance between the two markers is exactly one cycle.

To change the marker position, click on the  button, or click on the waveform window with the right mouse button and select Set Marker, and then click on the point where you want to put the marker. You can drag both markers with the mouse, or use the right and left arrow keys on your keyboard to change the marker position. Click on the waveform pane to allow the keyboard to get your input before using the keyboard.

## Using a Zoom

You can use a horizontal and a vertical zoom to change size of your waveforms. Use the buttons  on your local toolbar representing green arrowheads to zoom in or out of the waveform graph. Every click on these buttons gives you a 100-percent horizontal or 50-percent vertical zoom. Two buttons  give you a proportional zoom in both directions.

When in the overlapped waveform view, you can zoom in on a selected waveform region. Click on the waveform window with the right mouse button, click 'Zoom', point onto one of the corners of the region you want to zoom in, press and hold the left mouse button, then point to another corner of the selected region and release the mouse button.

## Delta Measurements

To measure the distance between two waveform points, click on the Delta button , then click on one point, and then click on the second point. The first reference point is still frozen until you close and reopen Delta, while the second point can be placed anywhere within the waveform line. You can measure a delta in both directions. To disable the Delta, click on the Delta button once again.

## 17.7 Viewing Synchronized Waveforms

If you have a number of devices with synchronized clocks, you can view waveforms recorded at different locations in one window. PAS can synchronize the time axes for different waveforms so they could be displayed in a single plot.

To get synchronized waveforms:

1. Put the databases with waveforms into the same folder, or put the sites from which you uploaded data to the same group in the sites tree.
2. Open a waveform you want to synchronize with other waveforms, and then click on the Multi-site View button . PAS searches for time-coordinated waveforms that have the same time span as your selected waveform.
3. Check the sites you want to see displayed.

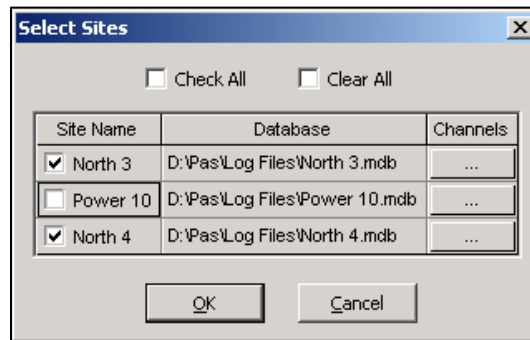





Figure 17-14

4. Click on the “Channels” button and select channels for each site.
5. Click OK.

To change the channels, click on the waveform window with the right mouse button and select “Channels...”.

Sometimes, it is useful to review a particular piece of historical data on-line at the time you expect new events to appear in the log. PAS allows you to retrieve historical data from a particular log without storing it to a file. The data appears only in the window on your screen. You can save it manually to the database.

To view the log data on-line, check the On-line button  on the PAS toolbar, select the log you want to retrieve in the Logs menu, and then click on the Poll button . Only new log records are retrieved from the device. If you want to review the entire log from the beginning, click on the Restore log button , and then click on the Poll button .

### NOTE

When reading multi-section profile data, only the first section is available for reading online.

See Chapter 17 [Viewing Log Files](#) for information on using different log views.

## 17.8 Exporting Files

### 17.8.1 Exporting Files in COMTRADE and PQDIF Formats

The COMTRADE and PQDIF file converters allow you to convert saved real-time waveforms into COMTRADE or PQDIF file format, and data log tables – into PQDIF format.

#### Manual Converting

To manually convert your waveforms or a data log into COMTRADE or PQDIF format:

1. Click on the Export  button on the PAS toolbar.

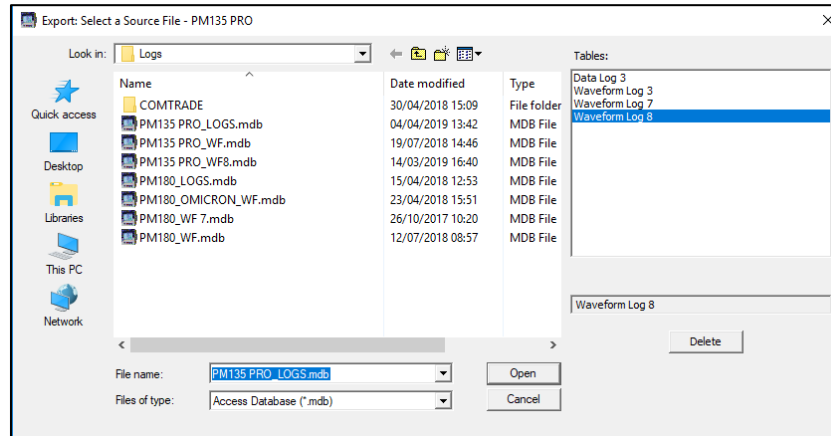

Figure 17-15

2. Select the database and a data log table you want to export, and then click Open.

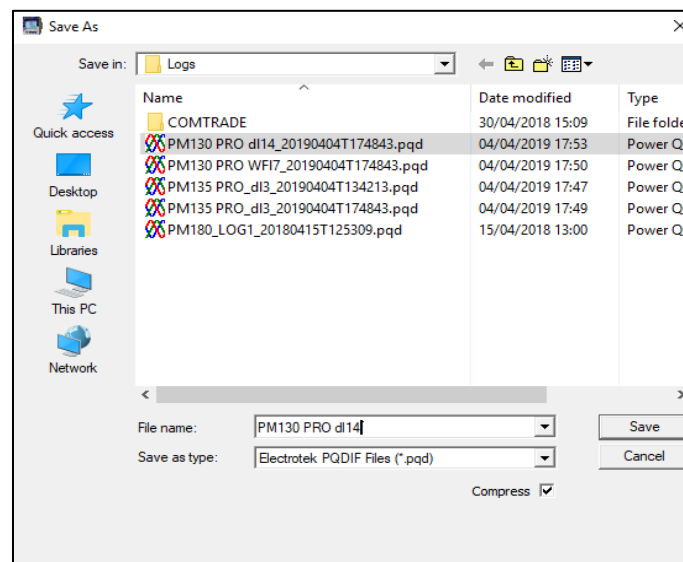

Figure 17-16

3. Select a folder where you want to store your exported files, type a file name that identifies your files, select a file output format, and then click on the Save button.
4. The PQDIF files are commonly recorded in compressed format. If you do not want your files to be compressed, uncheck the Compress box before saving the file.

In COMTRADE format, each waveform event is recorded into a separate file.

PQDIF file names are followed by a timestamp of the first event recorded to the file, and may look like follows:

PM130 PRO dl14\_20190404T174843.pqd.

## Automatic Converting

PAS allows you to automatically convert data logs into PQDIF format at the time you upload data from your devices via the Upload Scheduler.

To automatically convert your data log tables into PQDIF format:

1. Open the Upload Scheduler.
2. Highlight a desired device site with the left mouse button, and then click on the Export button.
3. Check the Enabled box for a data log or a waveform log table you want to automatically convert at the upload time.
4. Highlight the Record to... row for the selected table and click on the Browse button.
5. Select a folder where you want to store converted files, type in the converted file's name, select a desired output file format, and then click on Save.
6. Repeat the same for all tables you wish to be converted.
7. Click OK.

### 17.8.2 Exporting Files in Excel Format

PAS allows you to convert data tables into the Microsoft Excel workbook format, either manually, or automatically while retrieving data from your meters via the Upload Scheduler.

To store files in Excel format, follow instructions in the previous section and select Excel Workbook as the output file format.

The first row of the Excel table lists data names and the second row provides data codes, which identify recorded data points (see Modbus communications guide for data codes) that may be useful for automated table processing.

Each table row is provided with the device identifier that you can define in the meter database.

## 17.9 Archiving Files

Microsoft Access databases tend to grow fast. Databases above 0.5 Gigabytes can drastically slow down file operations.

To avoid enormous growing files, you can either periodically change the target database, or use the Upload Scheduler's file archiver to automatically move older data to archives.

The Upload Scheduler archives files upon a weekly, monthly or yearly schedule. When archiving data, a new database is created to where older data from your present database with the expired archiving date is moved.

An archive file keeps the original database name to which the date of the oldest database record is added, so you can easily identify your archives and work with them as you work with a regular database.

To provide a schedule for archiving files:

1. When defining a schedule for uploading files from your meter, click on Configure or double click on the site row.
2. Click Auto Archive.

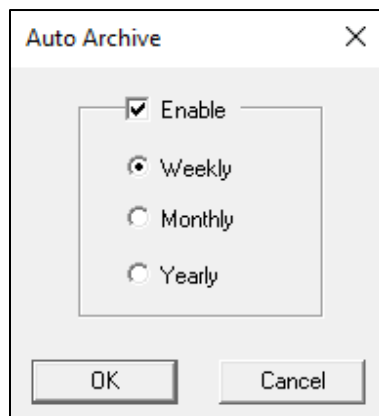

Figure 17-17

3. Check the Enable box and select a periodic schedule for archiving your files for this site.
4. Click OK.

To avoid archiving partially updated data, archiving is performed in a day after expiring a scheduled period and not before 2 hours a.m.

## Chapter 18 Technical Specifications

### 18.1 Environmental Conditions

Rated temperature range: with specified uncertainty: -25°C to +55°C (-13°F to 131°F)  
Limited Operating temperature range: no Hardware failures: -40°C to +60°C (-40°F to 140°F)  
Display limited Operating temperature range: -20°C to +60°C (-4°F to 140°F)  
Limited Storage temperature: -40°C to 85°C (-40°F to 185°F)  
Altitude: up to 2000m (>6561ft) above sea level  
Humidity: 0 to 95% non-condensing  
Degree of protection: IP51

### 18.2 Construction

Dimensions see Figure 3-1  
Weight: 0.70 kg (1.54 lb.)  
Materials  
Case enclosure: plastic PC/ABS blend  
Front panel: plastic PC  
PCB: FR4 (UL94-V0)  
Terminals: PBT (UL94-V0)  
Connectors-Plug-in type: Polyamide PA6.6 (UL94-V0)  
Packaging case: Carton and Stratocell® (Polyethylene Foam) brackets  
Labels: Polyester film (UL94-V0)

### 18.3 Power Supply Installation

Rated input: 85-277 V AC<sup>1</sup> @ 50/60 Hz, 100-290VDC (voltage is presented as nominal value, admissible tolerance of ± 15% from mains), Burden 11VA  
Isolation: 4000VAC @ 1min  
Wire size: up to 10 AWG (> 4.5 mm<sup>2</sup>)  
<sup>1</sup> UL Listing covers the nominal Voltage Input 85 - 240V L-N (CAT – III @ Pollution degree 2)

### 18.4 Input Ratings

#### Voltage input rating L-N (L-L) Measurement CAT IV

Operating range: 5 VAC (L-N)/ 8VAC (L-L) to 690 VAC (L-N)/ 1000 VAC (L-L)<sup>2</sup>  
Input impedance: 4000 kΩ  
Burden for 400V: < 0.04 VA  
Burden for 120V: < 0.01VA  
Over-voltage withstands: 1000 VAC continuous, 2000 VAC for 1 second  
Isolation: 4000VAC @ 1mn  
Wire size: up to 10 AWG (> 4.5 mm<sup>2</sup>)  
<sup>2</sup> UL Listing covers the nominal Voltage Input up to 277V L-N/ (480V L-L CAT – IV @ Pollution degree 2)

## Current Inputs (via CT) – Measurement CAT IV

Wire size: up to 10 AWG (> 4.5 mm<sup>2</sup>)

Galvanic isolation: 4000VAC @ 1min

1A or 5A rating from CT secondary (standard)

Operating range: continuous 4A RMS (In=1A) or 20A (In=5A) RMS

Burden: < 0.2 VA @ In=1A-5A

Overload withstands:

30A RMS continuous, 400A (20 x I<sub>max</sub>) RMS for ½ second (with 10AWG section wire)

20mA secondary via External Solid or Split core CT (HACS option)

External CT Operating range: continuous 100-3000A RMS (primary current)

Burden: < 0.02 VA @ nominal current

## 18.5 Optional Digital Inputs/outputs

### Built-in module option

#### Solid State relay option

1 relay rated at 50mA/250 V AC/DC, 1 contact (SPST Form A, Resistive load)

Galvanic isolation: 4000VAC @ 1mn

Operate time: 1 ms max.

Release time: 0.25 ms max.

Update time: 1 cycle

Connector type: removable, 2 pins.

Wire size: 14 AWG (up to 1.5 mm<sup>2</sup>)

#### 4RO optional module

- **Electromechanical relay - DRY contact (option1)**

4 relays rated at 5A/250 VAC; 5A/30 VDC, 1 contact (SPST Form A)

Galvanic isolation:

Between contacts and coil: 3000VAC @ 1mn

Between open contacts: 750 VAC

Operate time: 10 ms max.

Release time: 5 ms max.

Wire size: 14 AWG (up to 1.5 mm<sup>2</sup>)

- **Solid state relay - DRY contact (option2)**

4 relays rated at 100mA/250 VAC/VDC, 1 contact (SPST Form A)

Galvanic isolation:

Between contacts and coil: 5000VAC @ 1mn

Between open contacts: 800V peak

Operate time: 5 ms max.

Release time: 5 ms max.

Wire size: 14 AWG (up to 1.5 mm<sup>2</sup>)

Update time: 1 cycle

Wire size: 14 AWG (up to 1.5 mm<sup>2</sup>)

## 4DI/2RO or 8DI Optional Modules

Up to 3 optional modules of 4 or 8 Digital Inputs (4DI/2RO, 8DI Optional modules). EMR or SSR (4DI/2RO)

Dry Contacts, internally wetted @ 24VDC

Wet contact @ 250VDC

Sensitivity: Open @ input resistance >100 k $\Omega$ , Closed @ Input resistance < 100  $\Omega$  (dry contact)

Galvanic isolation: 4000VAC @ 1min

Internal power supply: 24VDC

Scan time: 1 ms

- **Electromechanical relay - DRY contact (4DI/2RO EMR)**

2 relays rated at 5A/250 VAC; 5A/30 VDC, 1 contact (SPST Form A)

Galvanic isolation:

Between contacts and coil: 3000VAC @ 1mn

Between open contacts: 750 VAC

Operate time: 10 ms max.

Release time: 5 ms max.

Wire size: 14 AWG (up to 1.5 mm<sup>2</sup>)

- **Solid state relay - DRY contact (4DI/2RO SSR)**

2 relays rated at 100mA/250 VAC/VDC, 1 contact (SPST Form A)

Galvanic isolation:

Between contacts and coil: 5000VAC @ 1mn

Between open contacts: 800V peak

Operate time: 5 ms max.

Release time: 5 ms max.

Wire size: 14 AWG (up to 1.5 mm<sup>2</sup>)

Update time: 1 cycle

Wire size: 14 AWG (up to 1.5 mm<sup>2</sup>)

Connector type: removable, 2 x 5 pins (8DI and 4DI/2RO)

Wire size: 14 AWG (up to 1.5 mm<sup>2</sup>)

## 4AO

$\pm 1$  mA, maximum load 5 k $\Omega$  (100% overload)

0-20 mA, maximum load 510  $\Omega$

4-20 mA, maximum load 510  $\Omega$

0-1 mA, maximum load 5 k  $\Omega$  (100% overload)

Accuracy: 0.5% FS

Update time: 1 ms

Wire Size: 14 AWG (up to 1.5 mm<sup>2</sup>)

Terminals Pitch: 5 mm

## DC input power supply

Input Voltage range of PS DC  
Rating: 24VDC: 9-36 VDC  
Isolation: 4000VAC @ 1min  
Wire size: up to 10 AWG (> 4.5 mm<sup>2</sup>)

## 18.6 Communication Ports

### COM

RS-485 optically isolated port  
Isolation: 4000VAC @ 1mn  
Baud rate: up to 115.2 kbps.  
Supported protocols: MODBUS RTU, DNP3, SATEC ASCII, IEC 60870-5-101  
Connector type: removable, 3 pins.  
Wire size: up to 14 AWG (up to 1.5 mm<sup>2</sup>).

### Ethernet Port (2 x ports)

Transformer-isolated 10/100BaseT Ethernet port  
Supported protocols: MODBUS/TCP (Port 502), DNP3/TCP (Port 20000), IEC 60870-5-104, IEC 61850  
Number of simultaneous connections: 10 (5 MODBUS/TCP + 5 DNP3/TCP).  
Isolation: 4000VAC @ 1mn  
Connector type: RJ45 modular.

## 18.7 Real-time Clock

Standard Meter Clock (PM17X PRO regular version)  
Battery backup clock  
Accuracy: typical error 15 seconds per month/ < 5 minutes/year @ 25°C  
Typical clock retention time: 24 months

## 18.8 Standards Compliance

### Accuracy:

Meets IEC62053-22:2020, class 0.2S

Meets IEC 62053-24:2020, class 0.5S

Meets ANSI C12.20 –2015, Current class 20, Accuracy class 0.2

### Electromagnetic Immunity:

Comply with IEC 61000-6-2:

IEC 61000-4-2 level 3: Electrostatic Discharge

IEC 61000-4-3 level 3: Radiated Electromagnetic RF Fields

IEC 61000-4-4 level 3: Electric Fast Transient

IEC 61000-4-5 level 3: Surge

IEC 61000-4-6 level 3: Conducted Radio Frequency

IEC 61000-4-8: Power Frequency Magnetic Field

Meets ANSI/IEEE C37.90.1: Fast Transient SWC

Electromagnetic Emission:

Complies with IEC 61000-6-4: Radiated/Conducted class B

Complies with IEC CISPR 22: Radiated/Conducted class B

### Safety/Construction:

Meets IEC/UL 61010-1, 3rd ed.

AC and Impulse Insulation:

Meets IEC 62052-11:

4000 VAC during 1 minute

6KV/500Ω @ 1.2/50 μs impulse

Degree of Protection: IP51

UL Listing covers the base unit, the optional modules are not a part of UL listing

### Power Quality:

IEC 61000-4-30 Ed.3.1: Power quality measurement methods

IEC 61000-4-7 Ed.2.1: General guide on harmonics and inter-harmonics measurement and instrumentation

IEC 61000-4-15 Ed.2: Flicker meter

IEC 62586-2 Ed.2 + AMD1: Power quality measurement in power supply system's Part 2: Functional tests and uncertainty requirements

EN50160:2022: Voltage characteristics of electricity supplied by public electricity networks

IEEE 519 IEEE Standard for Harmonic Control in Electric Power Systems, 2022

IEEE 1159: IEEE recommended practice for monitoring electric power quality

## 18.9 Special Sensor Interface

### GWP Sensor Interface

The SATEC PM17X PRO supports the following types of GWP Sensors:

**Table 41**

Type	Description
Current sensors	
NxxxR-xx	NxxxR-xx
N006E-9L	N006E-9L
N006E-0U	N006E-0U
L030T-0B	L030T-0B
N030T-9L1	N030T-9L1
N030T-0U	N030T-0U
N030R-0M	N030R-0M
L030T-0B	L030T-0B
Voltage sensors	
TxxxK-xx	TxxxK-xx
TxxxC-xx	TxxxC-xx

In case the sensor voltage output is 3.25V

The equation for PT calculation is :  $PT = \text{Vin} / \sqrt{3} / 230$

For example:  $33000 / \sqrt{3} / 230 = 82.8$

### Lindsey Sensor Interface

#### Environmental Conditions

Operating temperature: -30°C to 55°C (-22°F to 131°F)

Storage temperature: -30°C to 85°C (-40°F to 185°F)

Humidity: 0 to 95% non-condensing

#### Construction

Weight: 8.5 kg (18.74 lbs)

#### Materials

Case enclosure: Reinforced Polyester

Packaging case: Carton and Stratocell® (Polyethylene Foam) brackets

Labels: Polycarbonate (UL94-V0)

Ingress Protection: IP65

#### Power Supply inputs

120/230 VAC-DC Input:

Rated input: 85-265VAC 50/60/400 Hz, 88-290VDC, Burden 9VA

Lightening withstanding: 10,000A

12 VDC Input:

Rated input: 12 VDC  $\pm$  10%, 10W

Lightening withstanding: 1000A

All Power supply sources must be grounded to earth

Input Ratings

Voltage Inputs

Primary Measuring range: 11-33 kV AC line-to-line, 6.35-20 kV AC line-to-neutral

Input impedance: 1000 k $\Omega$

Current Inputs

Primary Measuring range: up to 600A

Lightening withstanding: 10,000A

Real-time Clock

Accuracy: typical error 1 minute per month @ 25°C

Typical clock retention time: 2 years

Standards Compliance

Accuracy:

Meet IEC62053-22, class 1

Electromagnetic Immunity:

Comply with IEC 61000-6-2:

IEC 61000-4-2 level 3: Electrostatic Discharge

IEC 61000-4-3 level 3: Radiated Electromagnetic RF Fields

IEC 61000-4-4 level 3: Electric Fast Transient

IEC 61000-4-5 level 4: Surge

IEC 61000-4-6 level 3: Conducted Radio Frequency

IEC 61000-4-8: Power Frequency Magnetic Field

Electromagnetic Emission:

Comply with IEC 61000-6-4: Radiated/Conducted class A

Comply with IEC CISPR 22: Radiated/Conducted class A

Safety/Construction: Meets UL/IEC 61010

The SATEC PM17X PRO supports the following types of Lindsey Sensors:

OVERHEAD: GEN2 Sensors:

Voltage, Current or Combined type

9E6x0\_Exx04\_50Hz/60Hz

9EHA6x0\_Exx04\_50Hz/60Hz

For Example: 25kV, Combined, 600A:10V, 10,000V:1V, 50Hz

9E660\_E1404\_50Hz

## Measured Parameter

Table 42: Measured and Displayed Parameters

Parameter	Display	Comm.	Analog	Pulse	Alarm
1-cycle Real-time Measurements					
RMS Voltage per phase		✓	✓		✓
RMS Current per phase		✓	✓		✓
kW per phase		✓			✓
kvar per phase		✓			✓
kVA per phase		✓			✓
Power Factor per phase		✓			✓
Total kW		✓	✓		✓
Total kvar		✓	✓		✓
Total kVA		✓	✓		✓
Frequency		✓	✓		✓
Neutral Current		✓	✓		✓
Total Power Factor		✓	✓		✓
Voltage & Current unbalance		✓			✓
1-sec Average Measurements					
RMS Voltage per phase	✓	✓	✓		✓
RMS Current per phase	✓	✓	✓		✓
kW per phase	✓	✓			✓
kvar per phase	✓	✓			✓
kVA per phase	✓	✓			✓
Power Factor per phase	✓	✓			✓
Total kW	✓	✓	✓		✓
Total kvar	✓	✓	✓		✓
Total kVA	✓	✓	✓		✓
Total Power Factor	✓	✓	✓		✓
Frequency	✓	✓	✓		✓
Neutral Current	✓	✓	✓		✓
Voltage & Current unbalance	✓	✓			✓
Amps & Volt Demands					
Ampere & Volt Demand per phase	✓	✓			✓
Ampere Maximum Demand per phase	✓	✓			✓
Voltage Maximum Demand per phase	✓	✓			✓
Power Demands					
kW Accumulated Demand Import & Export		✓	✓		✓
kvar Accumulated Demand Import & Export		✓	✓		✓
kVA Accumulated Demand		✓	✓		✓
kW Demand Import & Export		✓			✓
kvar Demand Import & Export		✓			✓
kVA Demand		✓			✓
kW Sliding Demand Import & Export		✓			✓
kvar Sliding Demand Import & Export		✓			✓
kVA Sliding Demand		✓			✓
kW Predicted Demand Import & Export		✓			✓
kvar Predicted Demand Import & Export		✓			✓
kVA Predicted Demand		✓			✓

Parameter	Display <sup>1</sup>	Comm.	Analog	Pulse	Alarm
kW Maximum Demand Import	✓	✓			
kW Maximum Demand Export	✓	✓			
kvar Maximum Demand Import	✓	✓			
kvar Maximum Demand Export	✓	✓			
kVA Maximum Demand	✓	✓			
Total Energy					
Total kWh Import & Export	✓	✓		✓	
Total kvarh Import & Export	✓	✓		✓	
Total kvarh Net		✓			
Total kVAh	✓	✓		✓	
Energy per Phase					
kWh Import per phase	✓	✓			
kvarh Import per phase	✓	✓			
kVAh per phase	✓	✓			
TOU Registers					
4 TOU energy registers (kWh and kvarh import & export, kVAh, 4 pulse sources)	✓	✓			
4 TOU maximum demand registers	✓	✓			
8 tariffs, 4 seasons x 4 types of day	✓	✓			✓
Harmonic Measurements					
Voltage THD per phase	✓	✓			✓
Current THD per phase	✓	✓			✓
Current TDD per phase	✓	✓			✓
K-factor per phase	✓	✓			✓
Voltage harmonics per phase up to order 63	✓	✓			
Current harmonics per phase up to order 63	✓	✓			
Voltage harmonic angles up to order 63	✓	✓			
Current harmonic angles up to order 63	✓	✓			
Fundamental Component					
Voltage and Current per phase	✓	✓			
kW, PF per phase	✓	✓			
kvar, KVA per phase	✓	✓			
Total kW, PF	✓	✓			
Total kvar, KVA	✓	✓			
Min/Max Logging					
Min/Max A, V, total kW, kvar, kVA, PF	✓	✓			
Min/Max Frequency, Neutral current	✓	✓			
Phase Rotation	✓	✓			✓
Voltage and Current Phase Angles	✓	✓			
Day and Time	✓	✓			
Pulse Counters	✓	✓			✓
Digital Inputs (optional)	✓	✓			✓
Relay Outputs (optional)	✓	✓			✓
Remote Relay Control (optional)		✓			
Alarm Triggers/Setpoints		✓			✓
Self-diagnostics	✓	✓			

## Measurement Specifications

Table 43: Measurement Specifications Parameters<sup>5</sup>

Parameter	Full Scale @ Input Range (if applicable)	Accuracy			Range
		% Reading	% FS	Conditions	
Voltage (L-L)	690V	0.1	0.01	10% to 120% FS	0 to 1,150,000 V Starting voltage 1.5% FS
Line current	CT	0.1	0.01	For $I_n = 5A$ 1% to 400% FS For $I_n = 1A$ 1% to 400% FS	0 to 50,000 A Starting current 0.1% $I_n$
Active power (total 3-phase)	$1.2 \times PT \times CT \times \sqrt{3}$ @ 690 V	0.2	0.01	$ PF  \geq 0.5$	-10,000,000 kW to +10,000,000 kW
Reactive power	$1.2 \times PT \times CT \times \sqrt{3}$ @ 690V	0.2	0.024	$ PF  \leq 0.9^1$	-10,000,000 kvar to +10,000,000 kvar
Apparent power	$1.2 \times PT \times CT \times \sqrt{3}$ @ 690V	0.2	0.01	$ PF  \geq 0.5^1$	0 to 10,000,000 kVA
Power factor	1.000		0.	$ PF  \geq 0.5,$ $I \geq 2\% FSI$	-0.999 to +1.000
Frequency		0.002		$V_{L-N} > 25V$	40 Hz to 70 Hz
Total Harmonic Distortion, THD V (I), % $V_f$ (% $I_f$ )	999.9	1.5	0.2	THD $\geq 1\%$ , $V \geq 10\% FSV$ and $V_{L-N} > 25V$ , $I \geq 10\% FSI$	0 to 999.9
Total Demand Distortion, TDD, %	100		1.5	TDD $\geq 1\%$ , $I \geq 10\% FSI$ , $V_{L-N} > 25V$	0 to 100
Active energy Import & Export		Class 0.2S under conditions as per IEC 62053-22:2020			0 to 999,999,999 kWh
Reactive energy Import & Export		Class 0.5S under conditions as per IEC 62053-24:2020			0 to 999,999,999 kvarh
Apparent energy		Class 0.2 under conditions as per IEC 61557-12:2018			0 to 999,999,999 kVAh

PT - external potential transformer ratio

CT - primary current rating of the external current transformer

FSV - voltage full scale

FSI - current full scale

$I_n$  – nominal current

$V_f$  - fundamental voltage

$I_f$  - fundamental current

<sup>5</sup> All values are being measured according to IEC 61000-4-30:2021 Ed. 3.1

**NOTES**

1. Accuracy is expressed as  $\pm$  (percentage of reading + percentage of full scale)  $\pm$  1 digit. This does not include inaccuracies introduced by the user's potential and current transformers. Accuracy calculated at 1second average.
2. Specifications assume: voltage and current waveforms with THD  $\leq$  5% for kvar, kVA and PF, and reference operating temperature 20°C - 26°C.

Measurement error is typically less than the maximum error indicated.

## Chapter 19 Analog Output Parameters

The following table lists parameters that can be provided on the meter's analog outputs.

**Table 44: Analog Output Parameters**

Display Code	Designation	Description
none	NONE	None (output disabled)
		1-Cycle Phase Values
rt.U1	V1/12 RT <sup>1</sup>	V1/V12 Voltage
rt.U2	V2/23 RT <sup>1</sup>	V2/V23 Voltage
rt.U3	V3/31 RT <sup>1</sup>	V3/V31 Voltage
rt.U12	V12 RT	V12 Voltage
rt.U23	V23 RT	V23 Voltage
rt.U31	V31 RT	V31 Voltage
rt.C1	I1 RT	I1 Current
rt.C2	I2 RT	I2 Current
rt.C3	I3 RT	I3 Current
		1-Cycle Total Values
rt. P	kW RT	Total kW
rt. q	kvar RT	Total kvar
rt. S	kVA RT	Total kVA
rt. PF	PF RT	Total PF
r.PF.LG	PF LAG RT	Total PF Lag
r.PF.Ld	PF LEAD RT	Total PF Lead
		1-Cycle Auxiliary Values
r.nEU.C	In RT	In Current
rt. Fr	FREQ RT	Frequency
		1-Sec Phase Values
Ar.U1	V1/12 AVR <sup>1</sup>	V1/V12 Voltage
Ar.U2	V2/23 AVR <sup>1</sup>	V2/V23 Voltage
Ar.U3	V3/31 AVR <sup>1</sup>	V3/V31 Voltage
Ar.U12	V12 AVR	V12 Voltage
Ar.U23	V23 AVR	V23 Voltage
Ar.U31	V31 AVR	V31 Voltage
Ar.C1	I1 AVR	I1 Current
Ar.C2	I2 AVR	I2 Current
Ar.C3	I3 AVR	I3 Current
		1-Sec Total Values
Ar. P	kW AVR	Total kW
Ar. q	kvar AVR	Total kvar
Ar. S	kVA AVR	Total kVA
Ar. PF	PF AVR	Total PF
A.PF.LG	PF LAG AVR	Total PF Lag
A.PF.Ld	PF LEAD AVR	Total PF Lead
		1-Sec Auxiliary Values
A.nEU.C	In AVR	In Current
Ar. Fr	FREQ AVR	Frequency
		Demands E, EH
Acd.P.i	kW IMP ACD	Accumulated kW import demand
Acd.P.E	kW EXP ACD	Accumulated kW export demand
Acd.q.i	kvar IMP ACD	Accumulated kvar import demand
Acd.q.E	kvar EXP ACD	Accumulated kvar export demand
Acd.S	kVA ACD	Accumulated kVA demand

<sup>1</sup> In 4LN3, 3LN3 and 3BLN3 wiring modes, the voltages will be line-to-neutral; for any other wiring mode, they will be line-to-line voltages.

## Chapter 20 Setpoint Triggers and Actions

Table 45: Setpoint Triggers

Display Code	Designation	Description
None	NONE	None (condition is not active)
		Status Inputs
DI1 On	STAT INP #1 ON	Status input #1 ON
DI2 On	STAT INP #2 ON	Status input #2 ON
DI3 On	STAT INP #3 ON	Status input #3 ON
DI4 On	STAT INP #4 ON	Status input #4 ON
DI5 On	STAT INP #5 ON	Status input #5 ON
DI6 On	STAT INP #6 ON	Status input #6 ON
DI7 On	STAT INP #7 ON	Status input #7 ON
DI8 On	STAT INP #8 ON	Status input #8 ON
DI9 On	STAT INP #9 ON	Status input #9 ON
DI10 On	STAT INP #10 ON	Status input #10 ON
DI11 On	STAT INP #11 ON	Status input #11 ON
DI12 On	STAT INP #12 ON	Status input #12 ON
DI1 OFF	STAT INP #1 OFF	Status input #1 OFF
DI2 OFF	STAT INP #2 OFF	Status input #2 OFF
DI3 OFF	STAT INP #3 OFF	Status input #3 OFF
DI4 OFF	STAT INP #4 OFF	Status input #4 OFF
DI5 OFF	STAT INP #5 OFF	Status input #5 OFF
DI6 OFF	STAT INP #6 OFF	Status input #6 OFF
DI7 OFF	STAT INP #7 OFF	Status input #7 OFF
DI8 OFF	STAT INP #8 OFF	Status input #8 OFF
DI9 OFF	STAT INP #9 OFF	Status input #9 OFF
DI10 OFF	STAT INP #10 OFF	Status input #10 OFF
DI11 OFF	STAT INP #11 OFF	Status input #11 OFF
DI12 OFF	STAT INP #12 OFF	Status input #12 OFF
		Relays
RO1 ON	RELAY #1 ON	Relay #1 ON
RO2 ON	RELAY #2 ON	Relay #2 ON
RO3 ON	RELAY #3 ON	Relay #3 ON
RO4 ON	RELAY #4 ON	Relay #4 ON
RO1 OFF	RELAY #1 OFF	Relay #1 OFF
RO2 OFF	RELAY #2 OFF	Relay #2 OFF
RO3 OFF	RELAY #3 OFF	Relay #3 OFF
RO4 OFF	RELAY #4 OFF	Relay #4 OFF
		Phase Reversal
Pos Phase Reversal	POS PHASE REVERSAL	Positive phase rotation reversal
Neg Phase Reversal	NEG PHASE REVERSAL	Negative phase rotation reversal
		Low/High 1-Cycle Values on any Phase
High Volt RT	HI VOLT RT <sup>1</sup>	High voltage
Low Volt RT	LO VOLT RT <sup>1</sup>	Low voltage
High Amps RT	HI AMPS RT	High current
Low Amps RT	LO AMPS RT	Low current
High Volt THD RT	HI V THD <sup>2</sup>	High voltage THD
High Current THD RT	HI I THD <sup>2</sup>	High current THD
High KF RT	HI KF RT	High K-Factor
High Current TDD RT	HI I TDD	High current TDD
		1-Cycle Auxiliary Values
High Freq RT	HI FREQ RT	High frequency
Low Freq RT	LO FREQ RT	Low frequency

Display Code	Designation	Description
High Volt Unb% RT	HI V UNB% RT <sup>1</sup>	High voltage unbalance
High Curr Unb% RT	HI I UNB% RT	High current unbalance
		1-Sec Phase Values
High I1 Avr	HI I1 AVR	High I1 current
High I2 Avr	HI I2 AVR	High I2 current
High I3 Avr	HI I3 AVR	High I3 current
Low I1 Avr	LO I1 AVR	Low I1 current
Low I2 Avr	LO I2 AVR	Low I2 current
Low I3 Avr	LO I3 AVR	Low I3 current
		1-Sec Values on any Phase
High Volt Avr	HI VOLT AVR <sup>1</sup>	High voltage
Low Volt Avr	LO VOLT AVR <sup>1</sup>	Low voltage
High Amps Avr	HI AMPS AVR	High current
Low Amps Avr	LO AMPS AVR	Low current
		1-Sec Total Values
High kW Imp Avr	HI kW IMP AVR	High total kW import
High kW Exp Avr	HI kW EXP AVR	High total kW export
High kvar Imp Avr	HI kvar IMP AVR	High total kvar import
High kvar Exp Avr	HI kvar EXP AVR	High total kvar export
High kVA Avr	HI kVA AVR	High total kVA
Low PF Lag Avr	HI PF LAG AVR	Low total PF Lag
Low PF Lead Avr	HI PF LEAD AVR	Low total PF Lead
		1-Sec Auxiliary Values
High In Avr	HI In AVR	High neutral current
High Freq Avr	HI FREQ RT	High frequency
Low Freq Avr	LO FREQ RT	Low frequency
		Demands
High V1/12 Dmd	HI V1/12 DMD <sup>1</sup>	High V1/V12 Volt demand
High V2/23 Dmd	HI V2/23 DMD <sup>1</sup>	High V2/V23 Volt demand
High V3/31 Dmd	HI V3/31 DMD <sup>1</sup>	High V3/V31 Volt demand
High I1 Dmd	HI I1 DMD	High I1 Ampere demand
High I2 Dmd	HI I2 DMD	High I2 Ampere demand
High I3 Dmd	HI I3 DMD	High I3 Ampere demand
High kW Imp BD	HI kW IMP BD	High block kW import demand
High kVA BD	HI kVA BD	High block kVA demand
High kW Imp SD	HI kW IMP SD	High sliding window kW import demand
High kVA SD	HI kVA SD	High sliding window kVA demand
High kW Imp Acc Dmd	HI kW IMP ACD	High accumulated kW import demand
High kVA Imp Acc Dmd	HI kVA ACD	High accumulated kVA demand
High kW Imp Prd Dmd	HI kW IMP PRD	High predicted kW import demand
High kVA Imp Prd Dmd	HI kVA PRD	High predicted kVA demand
		Time and Date Parameters
Day of Week	DAY OF WEEK	Day of week
Year	YEAR	Year
Monh	MONTH	Month
Day of Month	DAY OF MONTH	Day of month
Hours	HOURS	Hours
Minutes	MINUTES	Minutes
Seconds	SECONDS	Seconds
Minute Interval	MINUTE INTERVAL	Minute interval: 1-5, 10, 15, 20, 30, 60 min

<sup>1</sup> In 4LN3, 3LN3 and 3BLN3 wiring modes, the voltages will be line-to-neutral; for any other wiring mode, they will be line-to-line voltages.

Table 46: Setpoint Actions

Display Code	Designation	Description
None	NONE	None (no action)
Relay 1 ON	OPERATE RELAY #1	Operate relay RO1
Relay 2 ON	OPERATE RELAY #2	Operate relay RO2
Relay 3 ON	OPERATE RELAY #3	Operate relay RO3
Relay 4 ON	OPERATE RELAY #4	Operate relay RO4
Relay 1 OFF	RELEASE RELAY #1	Release latched relay RO1
Relay 2 OFF	RELEASE RELAY #2	Release latched relay RO2
Relay 3 OFF	RELEASE RELAY #3	Release latched relay RO3
Relay 4 OFF	RELEASE RELAY #4	Release latched relay RO4
Increment counter 1	INC CNT #1	Increment counter #1
Increment counter 2	INC CNT #2	Increment counter #2
Increment counter 3	INC CNT #3	Increment counter #3
Increment counter 4	INC CNT #4	Increment counter #4
Time counter 1	TIME CNT #1	Count operation time using counter #1
Time counter 2	TIME CNT #2	Count operation time using counter #2
Time counter 3	TIME CNT #3	Count operation time using counter #3
Time counter 4	TIME CNT #4	Count operation time using counter #4
Notification	NOTIFICATION	Send a notification message
Data Log 1	DATA LOG #1	Record data to Data Log #1

## Chapter 21 Parameters for Data Monitoring and Logging

The following table lists parameters measured by the meter that are available for monitoring through communications and for recording to an appendix. The left column shows data abbreviations used in PAS. Parameter groups are highlighted in bold.

**Table 47: Data Monitoring and Logging Parameters**

<b>Designation</b>	<b>Description</b>
NONE	None (stub, read as zero)
<b>DIGITAL INPUTS</b>	Digital Inputs
DI1:16	Digital Inputs Status DI1:DI12
<b>RELAYS</b>	Relays
RO1:16	Relay Status RO1:RO4
<b>COUNTERS</b>	Pulse Counters
COUNTER 1	Counter #1
COUNTER 2	Counter #2
COUNTER 3	Counter #3
COUNTER 4	Counter #4
RT PHASE	1-Cycle Phase Values
V1	V1/V12 Voltage <sup>1</sup>
V2	V2/V23 Voltage <sup>1</sup>
V3	V3/V31 Voltage <sup>1</sup>
I1	I1 Current
I2	I2 Current
I3	I3 Current
kW L1	kW L1
kW L2	kW L2
kW L3	kW L3
kvar L1	kvar L1
kvar L2	kvar L2
kvar L3	kvar L3
KVA L1	kVA L1
KVA L2	kVA L2
KVA L3	kVA L3
PF L1	Power factor L1
PF L2	Power factor L2
PF L3	Power factor L3
V1 THD	V1/V12 Voltage THD <sup>1</sup>
V2 THD	V2/V23 Voltage THD <sup>1</sup>
V3 THD	V3/V31 Voltage THD <sup>1</sup>
I1 THD	I1 Current THD
I2 THD	I2 Current THD
I3 THD	I3 Current THD
I1 KF	I1 K-Factor
I2 KF	I2 K-Factor
I3 KF	I3 K-Factor
I1 TDD	I1 Current TDD
I2 TDD	I2 Current TDD
I3 TDD	I3 Current TDD
V12	V12 Voltage
V23	V23 Voltage

Designation	Description
V31	V31 Voltage
RT TOTAL	1-Cycle Total Values
kW	Total kW
kvar	Total kvar
kVA	Total kVA
PF	Total PF
PF LAG	Total PF lag
PF LEAD	Total PF lead
kW IMP	Total kW import
kW EXP	Total kW export
kvar IMP	Total kvar import
kvar EXP	Total kvar export
V AVG	3-phase average L-N/L-L voltage
V LL AVG	3-phase average L-L voltage
I AVG	3-phase average current
RT AUX	1-Cycle Auxiliary Values
In	In (neutral) Current
FREQ	Frequency
V UNB%	Voltage unbalance <sup>2</sup>
I UNB%	Current unbalance <sup>2</sup>
AVR PHASE	1-Second Phase Values
V1	V1/V12 Voltage
V2	V2/V23 Voltage
V3	V3/V31 Voltage
I1	I1 Current
I2	I2 Current
I3	I3 Current
kW L1	kW L1
kW L2	kW L2
kW L3	kW L3
kvar L1	kvar L1
kvar L2	kvar L2
kvar L3	kvar L3
kVA L1	kVA L1
kVA L2	kVA L2
kVA L3	kVA L3
PF L1	Power factor L1
PF L2	Power factor L2
PF L3	Power factor L3
V1 THD	V1/V12 Voltage THD <sup>1</sup>
V2 THD	V2/V23 Voltage THD <sup>1</sup>
V3 THD	V3/V31 Voltage THD <sup>1</sup>
I1 THD	I1 Current THD
I2 THD	I2 Current THD
I3 THD	I3 Current THD
I1 KF	I1 K-Factor
I2 KF	I2 K-Factor
I3 KF	I3 K-Factor
I1 TDD	I1 Current TDD
I2 TDD	I2 Current TDD
I3 TDD	I3 Current TDD
V12	V12 Voltage

Designation	Description
V23	V23 Voltage
V31	V31 Voltage
AVR TOTAL	1-Second Total Values
kW	Total kW
kvar	Total kvar
kVA	Total kVA
PF	Total PF
PF LAG	Total PF lag
PF LEAD	Total PF lead
kW IMP	Total kW import
kW EXP	Total kW export
kvar IMP	Total kvar import
kvar EXP	Total kvar export
V AVG	3-phase average L-N/L-L voltage <sup>1</sup>
V LL AVG	3-phase average L-L voltage
I AVG	3-phase average current
AVR AUX	1-Second Auxiliary Values
In	In (neutral) Current
FREQ	Frequency
V UNB%	Voltage unbalance <sup>2</sup>
I UNB%	Current unbalance <sup>2</sup>
PHASORS	Phasors
V1 Mag	V1/V12 Voltage magnitude <sup>1</sup>
V2 Mag	V2/V23 Voltage magnitude <sup>1</sup>
V3 Mag	V3/V31 Voltage magnitude <sup>1</sup>
I1 Mag	I1 Current magnitude
I2 Mag	I2 Current magnitude
I3 Mag	I3 Current magnitude
V1 Ang	V1/V12 Voltage angle <sup>1</sup>
V2 Ang	V2/V23 Voltage angle <sup>1</sup>
V3 Ang	V3/V31 Voltage angle <sup>1</sup>
I1 Ang	I1 Current angle
I2 Ang	I2 Current angle
I3 Ang	I3 Current angle
DEMANDS	Present Demands (Power Demands E, EH)
V1 DMD	V1/V12 Volt demand <sup>1</sup>
V2 DMD	V2/V23 Volt demand <sup>1</sup>
V3 DMD	V3/V31 Volt demand <sup>1</sup>
I1 DMD	I1 Ampere demand
I2 DMD	I2 Ampere demand
I3 DMD	I3 Ampere demand
kW IMP BD	kW import block demand
kvar IMP BD	kvar import block demand
kVA BD	kVA block demand
kW IMP SD	kW import sliding window demand
kvar IMP SD	kvar import sliding window demand
kVA SD	kVA sliding window demand
kW IMP ACD	kW import accumulated demand
kvar IMP ACD	kvar import accumulated demand
kVA ACD	kVA accumulated demand
kW IMP PRD	kW import predicted sliding window demand

Designation	Description
kvar IMP PRD	kvar import predicted sliding window demand
kVA PRD	kVA predicted sliding window demand
PF IMP@kVA DMD	PF (import) at Maximum kVA sliding window demand
kW EXP BD	kW export block demand
kvar EXP BD	kvar export block demand
kW EXP SD	kW export sliding window demand
kvar EXP SD	kvar export sliding window demand
kW EXP ACD	kW export accumulated demand
kvar EXP ACD	kvar export accumulated demand
kW EXP PRD	kW export predicted sliding window demand
kvar EXP PRD	kvar export predicted sliding window demand
In DMD	In (neutral) current demand
SUMM ACC DMD	Billing Summary (Total) Accumulated Demands <sup>E, EH</sup>
REG1 ACD	Register #1 accumulated demand
REG2 ACD	Register #2 accumulated demand
REG3 ACD	Register #3 accumulated demand
REG4 ACD	Register #4 accumulated demand
SUMM BLK DMD	Billing Summary (Total) Block Demands <sup>E, EH</sup>
REG1 BD	Register #1 block demand
REG2 BD	Register #2 block demand
REG3 BD	Register #3 block demand
REG4 BD	Register #4 block demand
SUMM SW DMD	Billing Summary (Total) Sliding Demands <sup>E, EH</sup>
REG1 SD	Register #1 sliding demand
REG2 SD	Register #2 sliding demand
REG3 SD	Register #3 sliding demand
REG4 SD	Register #4 sliding demand
ENERGY	Total Energy <sup>E, EH</sup>
kWh IMPORT	kWh import
kWh EXPORT	kWh export
kvarh IMPORT	kvarh import
kvarh EXPORT	kvarh export
kVAh TOTAL	kVAh total
SUMMARY REGS	Billing Summary (Total) Energy Registers <sup>E, EH</sup>
SUM REG1	Summary energy register #1
SUM REG2	Summary energy register #2
SUM REG3	Summary energy register #3
SUM REG4	Summary energy register #4
PHASE ENERGY	Phase Energy <sup>E, EH</sup>
kWh IMP L1	kWh import L1
kWh IMP L2	kWh import L2
kWh IMP L3	kWh import L3
kvarh IMP L1	kvarh import L1
kvarh IMP L2	kvarh import L2
kvarh IMP L3	kvarh import L3
kVAh L1	kVAh total L1
kVAh L2	kVAh total L2
kVAh L3	kVAh total L3
%HD V1	V1/V12 Harmonic Distortions <sup>EH 1</sup>
V1 %HD01	H01 Harmonic distortion
V1 %HD02	H02 Harmonic distortion
...	...

Designation	Description
V1 %HD63	H63 Harmonic distortion
%HD V2	V2/V23 Harmonic Distortions <sup>EH 1</sup>
V2 %HD01	H01 Harmonic distortion
V2 %HD02	H02 Harmonic distortion
...	...
V2 %HD63	H63 Harmonic distortion
%HD V3	V3/V31 Harmonic Distortions <sup>EH 1</sup>
V3 %HD01	H01 Harmonic distortion
V3 %HD02	H02 Harmonic distortion
...	...
V3 %HD63	H63 Harmonic distortion
%HD I1	I1 Harmonic Distortions <sup>EH</sup>
I1 %HD01	H01 Harmonic distortion
I1 %HD02	H02 Harmonic distortion
...	...
I1 %HD63	H63 Harmonic distortion
%HD I2	I2 Harmonic Distortions <sup>EH</sup>
I2 %HD01	H01 Harmonic distortion
I2 %HD02	H02 Harmonic distortion
...	...
I2 %HD63	H63 Harmonic distortion
%HD I3	I3 Harmonic Distortions <sup>EH</sup>
I3 %HD01	H01 Harmonic distortion
I3 %HD02	H02 Harmonic distortion
...	...
I3 %HD63	H63 Harmonic distortion
ANG V1	V1/V12 Harmonic Angles <sup>EH 1</sup>
V1 H01 ANG	H01 Harmonic angle
V1 H02 ANG	H02 Harmonic angle
...	...
V1 H63 ANG	H63 Harmonic angle
ANG V2	V2/V23 Harmonic Angles <sup>EH 1</sup>
V2 H01 ANG	H01 Harmonic angle
V2 H02 ANG	H02 Harmonic angle
...	...
V2 H63 ANG	H63 Harmonic angle
ANG V3	V3/V31 Harmonic Angles <sup>EH 1</sup>
V3 H01 ANG	H01 Harmonic angle
V3 H02 ANG	H02 Harmonic angle
...	...
V3 H63 ANG	H63 Harmonic angle
ANG I1	I1 Harmonic Angles <sup>EH</sup>
I1 H01 ANG	H01 Harmonic angle
I1 H02 ANG	H02 Harmonic angle
...	...
I1 H63 ANG	H63 Harmonic angle
ANG I2	I2 Harmonic Angles <sup>EH</sup>
I2 H01 ANG	H01 Harmonic angle
I2 H02 ANG	H02 Harmonic angle
...	...
I2 H63 ANG	H63 Harmonic angle
ANG I3	I3 Harmonic Angles <sup>EH</sup>

Designation	Description
I3 H01 ANG	H01 Harmonic angle
I3 H02 ANG	H02 Harmonic angle
...	...
I3 H63 ANG	H63 Harmonic angle
H1 PHASE	Fundamental (H01) Phase Values
V1 H01	V1/V12 Voltage <sup>1</sup>
V2 H01	V2/V23 Voltage <sup>1</sup>
V3 H01	V3/V31 Voltage <sup>1</sup>
I1 H01	I1 Current
I2 H01	I2 Current
I3 H01	I3 Current
kW L1 H01	kW L1
kW L2 H01	kW L2
kW L3 H01	kW L3
kvar L1 H01	kvar L1
kvar L2 H01	kvar L2
kvar L3 H01	kvar L3
kVA L1 H01	kVA L1
kVA L2 H01	kVA L2
kVA L3 H01	kVA L3
PF L1 H01	Power factor L1
PF L2 H01	Power factor L2
PF L3 H01	Power factor L3
HRM TOT POW	Fundamental and Harmonic Total Power Values
kW H01	Total fundamental kW
kvar H01	Total fundamental kvar
kVA H01	Total fundamental kVA
PF H01	Total fundamental PF
MIN PHASE	Minimum 1-Cycle Phase Values
V1 MIN	V1/V12 Voltage <sup>1</sup>
V2 MIN	V2/V23 Voltage <sup>1</sup>
V3 MIN	V3/V31 Voltage <sup>1</sup>
I1 MIN	I1 Current
I2 MIN	I2 Current
I3 MIN	I3 Current
MIN TOTAL	Minimum 1-Cycle Total Values
kW MIN	Total kW
kvar MIN	Total kvar
kVA MIN	Total kVA
PF MIN	Total PF
MIN AUX	Minimum 1-Cycle Auxiliary Values
In MIN	In Current
FREQ MIN	Frequency
MAX PHASE	Maximum 1-Cycle Phase Values
V1 MAX	V1/V12 Voltage <sup>1</sup>
V2 MAX	V2/V23 Voltage <sup>1</sup>
V3 MAX	V3/V31 Voltage <sup>1</sup>
I1 MAX	I1 Current
I2 MAX	I2 Current
I3 MAX	I3 Current
MAX TOTAL	Maximum 1-Cycle Total Values

Designation	Description
kW MAX	Total kW
kvar MAX	Total kvar
kVA MAX	Total kVA
PF MAX	Total PF
MAX AUX	Maximum 1-Cycle Auxiliary Values
In MAX	In Current
FREQ MAX	Frequency
MAX DMD	Maximum Demands (Power Demands E, EH)
V1 DMD MAX	V1/V12 Maximum volt demand <sup>1</sup>
V2 DMD MAX	V2/V23 Maximum volt demand <sup>1</sup>
V3 DMD MAX	V3/V31 Maximum volt demand <sup>1</sup>
I1 DMD MAX	I1 Maximum ampere demand
I2 DMD MAX	I2 Maximum ampere demand
I3 DMD MAX	I3 Maximum ampere demand
kW IMP SD MAX	Maximum kW import sliding window demand
kW EXP SD MAX	Maximum kvar import sliding window demand
kvar IMP SD MAX	Maximum kW export sliding window demand
kvar EXP SD MAX	Maximum kvar export sliding window demand
kVA SD MAX	Maximum kVA sliding window demand
In DMD MAX	In (neutral) current maximum demand
MAX SUMMARY DMD	Billing Summary (Total) Maximum Demands E, EH
REG1 MD	Summary register #1 maximum demand
REG2 MD	Summary register #2 maximum demand
REG3 MD	Summary register #3 maximum demand
REG4 MD	Summary register #4 maximum demand
AO RAW	Raw Analog Outputs (A/D Units)
AO1	Analog output AO1
AO2	Analog output AO2
AO3	Analog output AO3
AO4	Analog output AO4
TOU PRMS	TOU Parameters E, EH
ACTIVE TARIFF	Active TOU tariff
ACTIVE PROFILE	Active TOU profile
TOU REG1	Billing TOU Energy Register #1 E, EH
REG1 TRF1	Tariff #1 register
REG1 TRF2	Tariff #2 register
...	...
REG1 TRF8	Tariff #8 register
TOU REG2	Billing TOU Energy Register #2 E, EH
REG2 TRF1	Tariff #1 register
REG2 TRF2	Tariff #2 register
...	...
REG2 TRF8	Tariff #8 register
TOU REG3	Billing TOU Energy Register #3 E, EH
REG3 TRF1	Tariff #1 register
REG3 TRF2	Tariff #2 register
...	...
REG3 TRF8	Tariff #8 register
TOU REG4	Billing TOU Energy Register #4 E, EH
REG4 TRF1	Tariff #1 register
REG4 TRF2	Tariff #2 register
...	...

Designation	Description
REG4 TRF8	Tariff #8 register
TOU MAX DMD REG1	Billing TOU Maximum Demand Register #1 <sup>E, EH</sup>
REG1 TRF1 MD	Tariff #1 maximum demand
REG1 TRF2 MD	Tariff #2 maximum demand
...	...
REG1 TRF8 MD	Tariff #8 maximum demand
TOU MAX DMD REG2	Billing TOU Maximum Demand Register #2 <sup>E, EH</sup>
REG2 TRF1 MD	Tariff #1 maximum demand
REG2 TRF2 MD	Tariff #2 maximum demand
...	...
REG2 TRF8 MD	Tariff #8 maximum demand
TOU MAX DMD REG3	Billing TOU Maximum Demand Register #3 <sup>E, EH</sup>
REG3 TRF1 MD	Tariff #1 maximum demand
REG3 TRF2 MD	Tariff #2 maximum demand
...	...
REG3 TRF8 MD	Tariff #8 maximum demand
TOU MAX DMD REG4	Billing TOU Maximum Demand Register #4 <sup>E, EH</sup>
REG4 TRF1 MD	Tariff #1 maximum demand
REG4 TRF2 MD	Tariff #2 maximum demand
...	...
REG4 TRF8 MD	Tariff #8 maximum demand

<sup>1</sup> In 4LN3, 3LN3 and 3BLN3 wiring modes, the voltages will be line-to neutral; for any other wiring mode, they will be line-to-line voltages.

<sup>2</sup> The value is calculated as a relation of the maximum deviation of phase values from a 3-phase average value to a 3-phase average.

**NOTE**

Designations of some engineering demands and billing energy and demand registers are shown using a short name notation available in PAS V1.4. By default, PAS uses long names compatible with older versions of PAS. You can select a desired notation from the Tools/Options/Preferences tab.

PAS does not allow to store data in files using different data names. If you have a file uploaded with a previous version of PAS using long data names, either continue using long data names, or store data in a new file.

See table below for a list of parameters with short and long names.

**Table 48**

Short Data Name	Long Data Name	Description
kW IMP ACD	kW IMP ACC DMD	Accumulated demand
kW IMP PRD	kW IMP PRD DMD	Predicted sliding window demand
PF IMP@kVA MD	PF IMP@kVA MXDMD	PF (import) at maximum kVA demand
REG1 ACD	SUM REG1 ACC DMD	Billing summary (total) register accumulated demand
REG1 BD	SUM REG1 BLK DMD	Billing summary (total) register block demand
REG1 SD	SUM REG1 SW DMD	Billing summary (total) register sliding demand
REG1	SUM REG1	Billing summary (total) energy register
REG1 MD	SUM REG1 DMD MAX	Billing summary (total) register maximum demand
REG1 TRF1	TOU REG1 TRF1	Billing tariff energy register
REG1 TRF1 MD	DMD1 TRF1 MAX	Billing tariff register maximum demand
TRF1	SEASON TRF1	Generic billing tariff energy register
TRF1 MD	SEASON TRF1	Generic billing tariff register maximum demand

## Chapter 22 Billing/TOU Profile Log File

The following table shows the record structure for the daily billing data profile log file.

The second column shows data abbreviations used in the PAS data log reports. Data log file sections are highlighted in bold.

**Table 49: Daily Billing/TOU Profile Data Log (Data Log #16)**

<b>Field No.</b>	<b>Designation</b>	<b>Description</b>
		Energy Register #1
1	REG1	Summary (total) energy reading
2	TRF1	Tariff #1 energy reading
3	TRF2	Tariff #2 energy reading
4	TRF3	Tariff #3 energy reading
5	TRF4	Tariff #4 energy reading
6	TRF5	Tariff #5 energy reading
7	TRF6	Tariff #6 energy reading
8	TRF7	Tariff #7 energy reading
9	TRF8	Tariff #8 energy reading
		...
		Energy Register #4
1	REG4	Summary (total) energy reading
2	TRF1	Tariff #1 energy reading
3	TRF2	Tariff #2 energy reading
4	TRF3	Tariff #3 energy reading
5	TRF4	Tariff #4 energy reading
6	TRF5	Tariff #5 energy reading
7	TRF6	Tariff #6 energy reading
8	TRF7	Tariff #7 energy reading
9	TRF8	Tariff #8 energy reading
		Daily Maximum Demand Register #1
1	REG1 MD	Summary (total) max. demand reading
2	TRF1 MD	Tariff #1 max. demand reading
3	TRF2 MD	Tariff #2 max. demand reading
4	TRF3 MD	Tariff #3 max. demand reading
5	TRF4 MD	Tariff #4 max. demand reading
6	TRF5 MD	Tariff #5 max. demand reading
7	TRF6 MD	Tariff #6 max. demand reading
8	TRF7 MD	Tariff #7 max. demand reading
9	TRF8 MD	Tariff #8 max. demand reading
		...
		Daily Maximum Demand Register #4
1	REG4 MD	Summary (total) max. demand reading
2	TRF1 MD	Tariff #1 max. demand reading
3	TRF2 MD	Tariff #2 max. demand reading
4	TRF3 MD	Tariff #3 max. demand reading
5	TRF4 MD	Tariff #4 max. demand reading
6	TRF5 MD	Tariff #5 max. demand reading
7	TRF6 MD	Tariff #6 max. demand reading
8	TRF7 MD	Tariff #7 max. demand reading
9	TRF8 MD	Tariff #8 max. demand reading

The number of parameters in each section is automatically configured depending on the number of actual tariffs you defined in the TOU Daily Profiles.

## Chapter 23 Data Scales

The maximum values for volts, amps and power in the PM17X PRO setup and in communications are limited by the voltage and current scale settings. See [Device Options](#) in 8 on how to change the voltage and current scales in your meter.

The following table shows the meter data scales.

**Table 50: Data Scales Values**

Scale	Conditions	Range
Maximum voltage (V max)	All configurations	Voltage scale $\times$ PT Ratio, V <sup>1</sup>
Maximum current (I max)	All configurations	Current scale $\times$ CT Ratio, A <sup>2, 3</sup>
Maximum Power <sup>4</sup>	Wiring 4LN3, 3LN3, 3BLN3	V max $\times$ I max $\times$ 3, W
	Wiring 4LL3, 3LL3, 3BLL3, 3OP2, 3OP3, 3DIR2	V max $\times$ I max $\times$ 2, W
Maximum frequency	25, 50 or 60 Hz	100 Hz
	400Hz	500 Hz

<sup>1</sup> The default voltage scale is 144V. The recommended voltage scale is 120V+20% = 144V for using with external PT's, and 690V+20% = 828V for a direct connection to power line.

<sup>2</sup> CT Ratio = CT primary current/CT secondary current

<sup>3</sup> The default current scale is 2  $\times$  CT secondary (2.0A with 1A secondary and 10.0A with 5A secondary).

<sup>4</sup> Maximum power is rounded to whole kilowatts. With PT=1.0, it is limited to 9,999,000 W.

## Chapter 24 Device Diagnostic Codes

Table 51: Device Diagnostic Codes

Diagnostic Display	Diagnostic Message	Description	Reason
RAM/DATA fault	RAM/DATA Fault	Memory/Data fault	Hardware failure
HW watchdog reset	HW Watchdog Reset	Hardware watchdog reset	Hardware failure
CPU exception	CPU Exception	CPU exception	Hardware failure
Run-time error	Run-time Error	Run-time software error	Hardware failure
SW watchdog reset	SW Watchdog Reset	Software watchdog timeout	Hardware failure
Power down/Up	Power Down	Power Down/Up	Normal power-up sequence
External restart	Device Reset	Warm restart	External restart via communications or by firmware upgrade
Configuration reset	Configuration Reset	Configuration reset	Corrupted setup data has been replaced with the default configuration
RTC fault	RTC Fault	RTC fault	The clock time has been lost
EEPROM fault	EEPROM Fault	EEPROM fault	Hardware failure

See Diagnostics Display in Chapter 3 for more information on the PM17X PRO built-in diagnostics.