

PM130 Series Powermeter - Quick Start

Typical Mechanical Installation

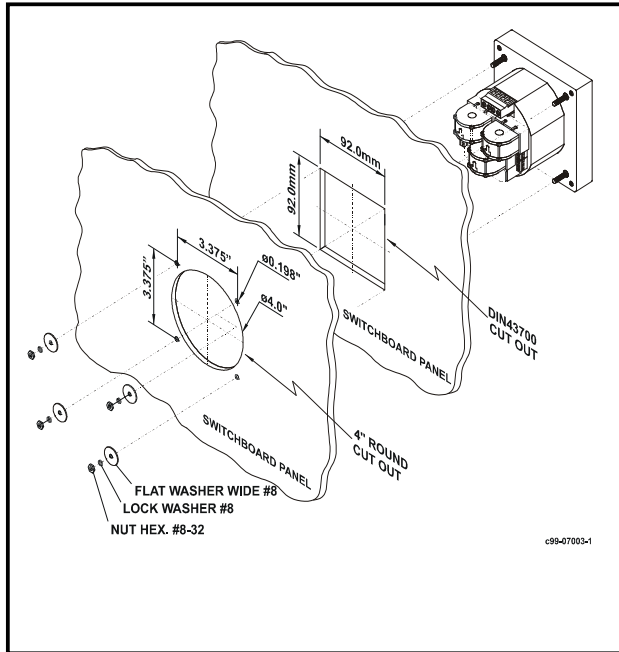

Figure 1: Mounting the PM130 (Square or Round Cut-out)

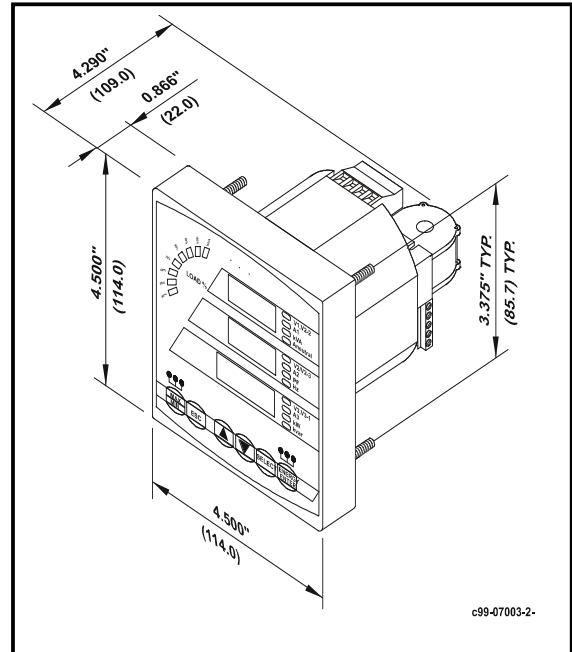

Figure 2: Physical Dimensions

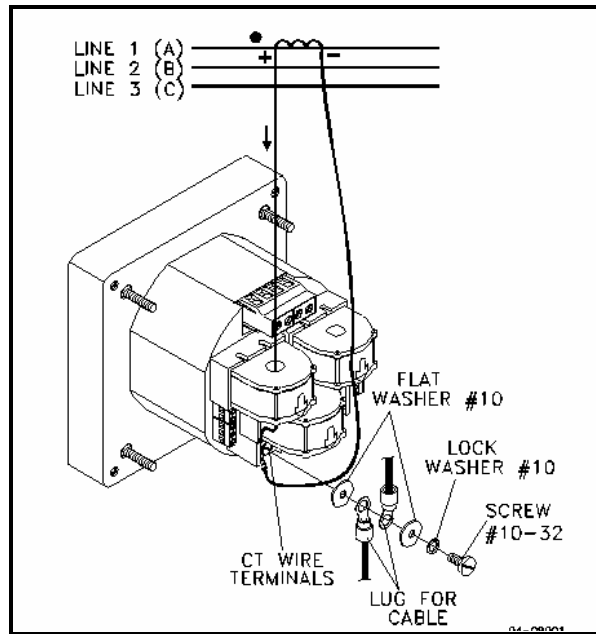

Figure 3: CT Wiring

IMPORTANT!

All incoming power sources must be turned off during installation. Setup can be performed by qualified personnel only. During operation of the meter, hazardous voltages are present on the input terminals. Failure to observe precautions can result in serious or even fatal injury, or damage to equipment. Please refer to the installation and operation manual for further information.

Typical Electrical Installation

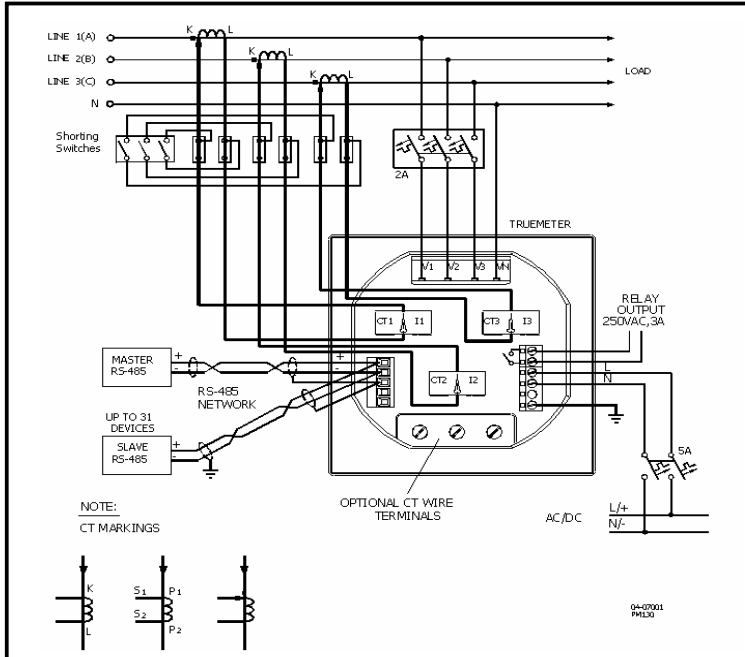

Figure 4: Common Wiring Mode: 4LL3 or 4Ln3*

3OP2	3-wire open delta using 2 CTs
4Ln3*	4-wire Wye using 3 PTs
3dir2	3-wire direct connection using 2 CTs
4LL3	4-wire Wye using 3 PTs
3OP3	3-wire open delta using 3 CTs
3Ln3	4-wire Wye using 2 PTs
3LL3	4-wire Wye using 2 PTs

NOTE:

Refer to the User Guide for the wiring schematics diagrams

*connect the ground PM130 terminals of the power supply and of the communication connectors to the switchgear earth ground, using 1.5 mm²/14AWG dedicated wire.

Elementary Setup

All setups can be performed directly from the display panel or via communications using PAS communication software, except for **Communications** and **Display** setups, which must be performed directly on the instrument panel.

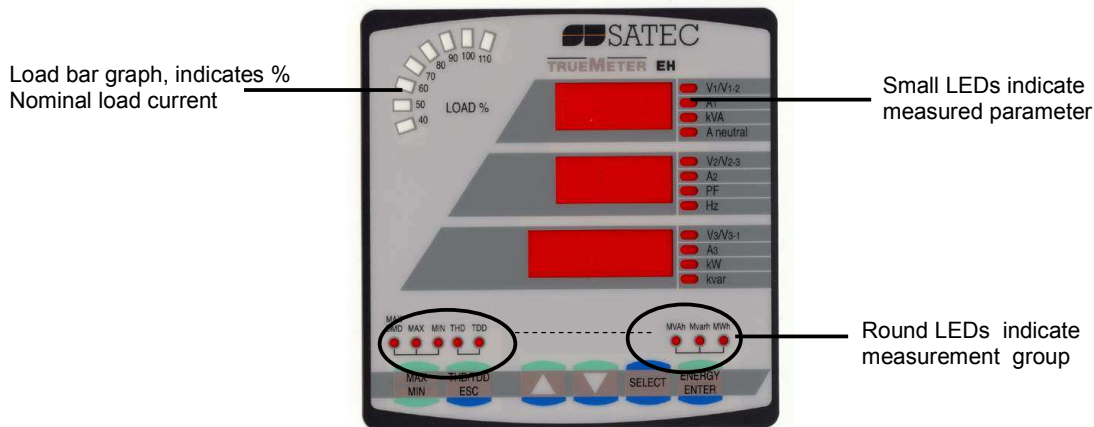

To set the CT Primary current, perform the following steps:

- Press **SELECT** 3 times: CHG should blink.
- Press **ENTER** 2 times:
- Press **▲** 2 times:
- Press **SELECT**: "5" should blink.
- Use the **▲▼** arrows to scroll to the desired value (press **▲▼** continuously for quick scrolling).
- Press **ENTER** to save the selected value.
- Press **ESC** (X3) to return to the display menu.

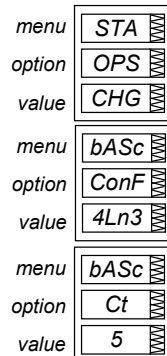

Performing Basic and Communications Setup

- Press **SELECT** (X3) → **CHG** → **ENTER**
- Press **▲▼** to scroll to desired menu.
- Press **ENTER** to activate middle window.
- Press **▲▼** to scroll to desired option.
- Press **SELECT** to activate lower window.
- Press **▲▼** to scroll to desired value.
- Press **ENTER** to save selected value.
- Press **ESC** (X3) to return to the display menu.

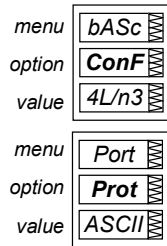



DATA DISPLAY

Navigating in Display Mode

The front panel has a simple interface that allows you to display numerous measurement parameters in up to 38 display pages. For easier reading, the parameters are divided into three groups, each accessible by a designated key. These are:

- **Common measurements** - no selection key
- **Min/Max measurements** - selected by the **MAX/MIN** key
- **Energy measurements** - selected by the **ENERGY** key

The up/down arrow keys are used as follows in Display Mode:

-  Scrolls through the pages downward (forward)
-  Scrolls through the pages upward (backward)
-  Returns to the first page within current measurement group

For each display page, up to three parameters can be displayed. The Load bar graph displays the percentage of the highest of 3 phases current measured by the PM130.

Selecting a Display Page

- Press the **▲▼** to scroll through display pages.

Selecting Common Measurements

- Press the key pointed to by the illuminated round LED below the front panel display. If no LED is lit up, the front panel is currently displaying the common measurements parameters.

Selecting Min/Max Measurements

- Press the **MAX/MIN** key. Use the **▲▼** to scroll through Min/Max and Max. demand measurements.

Selecting Energy Measurements

- Press the **ENERGY** key. Use the **▲▼** to scroll through the different energy readings.

Basic Menu

Code	Parameter	Options	Description
<i>ConF</i>	Wiring mode	3OP2	3-wire open delta using 2 CTs
		4Ln3*	4-wire Wye using 3 PTs
		3dir2	3-wire direct connection using 2 CTs
		4LL3	4-wire Wye using 3 PTs
		3OP3	3-wire open delta using 3 CTs
		3Ln3	4-wire Wye using 2 PTs
		3LL3	4-wire Wye using 2 PTs
<i>Pt</i>	PT ratio	1.0* - 6,500.0	The potential transformer ratio
<i>Ct</i>	CT primary current	1-50,000A (5*)	The primary rating of the current transformer
<i>d.P</i> <i>PM130E</i>	Power demand period	1, 2, 5, 10, 15*, 20, 30, 60, E	The length of the period for power demand calculations, in minutes . E = external synchronization
<i>n.dp</i> <i>PM130E</i>	Number of power demand periods	1-15 (1*)	The number of demand periods to be averaged for sliding window demands 1 = block interval demand calculation
<i>A.dP</i>	Ampere/Volt demand period	0-1800 (900*)	The length of the period for volt/ampere demand calculations, in seconds . 0 = measuring peak current
<i>buF</i>	Averaging buffer size	8*, 16, 32	The number of cycles for RMS sliding averaging
<i>rSt</i>	Reset enable/disable	diS*, En	Protects all reset functions, both via the front panel or communications
<i>Freq</i>	Nominal frequency	50, 60 Hz	The nominal power utility frequency

Communication (Port Menu)

Code	Parameter	Options	Description
<i>Prot</i>	Communications protocol	ASCII*, rtu, dnP3	ASCII, Modbus RTU or DNP3.0 protocol
<i>rS</i>	Interface standard	485	RS-485 interface (not changeable)
<i>Addr</i>	Address	ASCII: 0*-99, Modbus: 1*-247, DNP3.0: 0*-255	
<i>bAud</i>	Baud rate	110, 300, 600, 1200, 2400, 4800, 9600*, 19200 bps	
<i>dAtA</i>	Data format	7E , 8E (7/8 bits, even parity), 8n* (8 bits, no parity)	

Input and Output Ratings

3 voltage inputs	690 V: (standard)	DIRECT INPUT - Nominal: 690V line-to-line voltage, 790V maximum; 400V line-to-neutral, 460V maximum - Burden: <0.5 VA. INPUT USING PT - Burden: <0.15 VA
	120 V: (optional)	INPUT USING PT - Nominal: 120V line-to-line voltage, 144V maximum - Burden: <0.1 VA
3 current inputs (galvanically isolated)	5A: (standard)	INPUT VIA CT with 5A secondary output - Burden: 2.5 to 4 mm2 (13-11 AWG) wire from CT Overload withstand: 15A RMS continuous, 250A RMS for 1 second.
	1A: (optional)	INPUT VIA CT with 1A secondary output - Burden: 2.5 to 4 mm2 (13-11 AWG) wire from CT Overload withstand: 3A RMS continuous, 50A RMS for 1 second.
Voltage input terminals		Maximum wire section: 4 mm2 (10 AWG)
Optically isolated communication ports		EIA RS-485 standard . Maximum wire section: 2.5 mm2 (12 AWG)
Relay outputs		Relay rated at 3A, 250 V AC / 3A, 30 V DC / 0.5A, 110 V DC. Maximum wire section: 1.5 mm2 (14 AWG) 2 contacts (SPST Form A)
Power Supply Galvanically isolated power supply (factory set) 120 or 230 V AC AC/DC power supply available upon special order		Maximum wire section: 1.5 mm2 (14 AWG) 88-138V AC or 176-265V AC; 50/60 Hz; Burden: 5 VA 85-265VAC , 88-290VDC ; 50/60 Hz 9VA