

RDM172 Remote Display Module

QUICK GUIDE

The RDM172 is an optional remote display for the PM172 Powermeter. It features a bright LED display (3 windows with 6 LEDs each), 18 LED indicators, two communication receive/transmit LEDs, 6 control push-buttons, and a communication port (RS-485). The RDM172 uses the Modbus RTU transmission protocol for communication with the PM172 and acts as the Master.

The RDM172 offers approximately the same functions as the PM172 front panel, and supports both the PM172P and PM172E models without additional adjustment. See the *PM172 Installation and Operation Manual* for information on the display panel.

IMPORTANT

Please read instructions contained in this manual before performing installation, and take note of the following precautions:

1. **Ensure that the incoming DC power source is turned OFF** before performing any work on the instrument. Failure to do so may result in serious or even fatal injury and/or equipment damage.
2. **Before connecting the instrument to the power source, check** that your power supply has 12V \pm 15% voltage and 350mA current.
3. **Under no circumstances should the instrument be connected to a power source if it is damaged.**
4. **To prevent potential fire or shock hazard, do not expose the instrument to rain or moisture.**
5. **Mount the instrument away from heat sources in a dirt-free environment.** Do not operate the instrument in direct sunlight.
6. **Setup procedures must be performed only by qualified personnel** familiar with the instrument and its associated electrical equipment.
7. **DO NOT attempt to open the instrument under any circumstances.**
8. **Although designed to operate in an electrically noisy environment,** the instrument should not be placed near very high electric fields. In the event that the instrument is mounted in a harsh, noisy environment with high potential for electromagnetic impulses from heavy switch gears, motors or lightning, it is recommended to install appropriate protective devices such as lightning and over-voltage arresters to incoming voltage and communication inputs.

LIMITED WARRANTY

The manufacturer offers the customer a 24-month functional warranty on the instrument for faulty workmanship or parts from date of dispatch from the distributor. In all cases, this warranty is valid for 36 months from the date of production. This warranty is on a return to factory basis.

The manufacturer does not accept liability for any damage caused by instrument malfunction. The manufacturer accepts no responsibility for the suitability of the instrument to the application for which it was purchased.

Failure to install, setup or operate the instrument according to the instructions herein will void the warranty.

Your instrument may be opened only by a duly authorized representative of the manufacturer. The unit should only be opened in a fully anti-static environment. Failure to do so may damage the electronic components and will void the warranty.

NOTE

The greatest care has been taken to manufacture your instrument. However, these instructions do not cover all possible contingencies that may arise during installation, operation or maintenance, and not all details and variations of this equipment are covered by these instructions.

For additional information regarding installation, operation or maintenance of this instrument, contact the manufacturer or your local representative or distributor.

Table of Contents

1	<i>Mechanical Installation</i>	3
1.1	<i>Standard Cutouts (round or square)</i>	3
1.2	<i>Special Cutouts</i>	4
2	<i>Electrical Installation</i>	5
3	<i>Setup on the RDM</i>	6
3.1	<i>Instrument Setup Menus</i>	6
3.2	<i>Performing RDM Communication Adjustment</i>	6
3.3	<i>RDM Setup Menu</i>	6
4	<i>Status Information Menu</i>	8
5	<i>Troubleshooting: Fault Condition Display</i>	9
6	<i>Communications</i>	9

1 Mechanical Installation

1.1 Standard Cutouts (round or square)

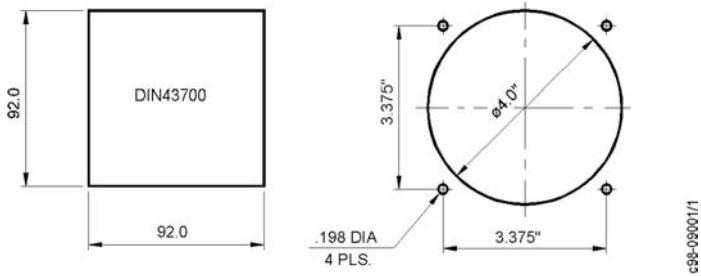

Figure 1-1 RDM172 Cutout Dimensions

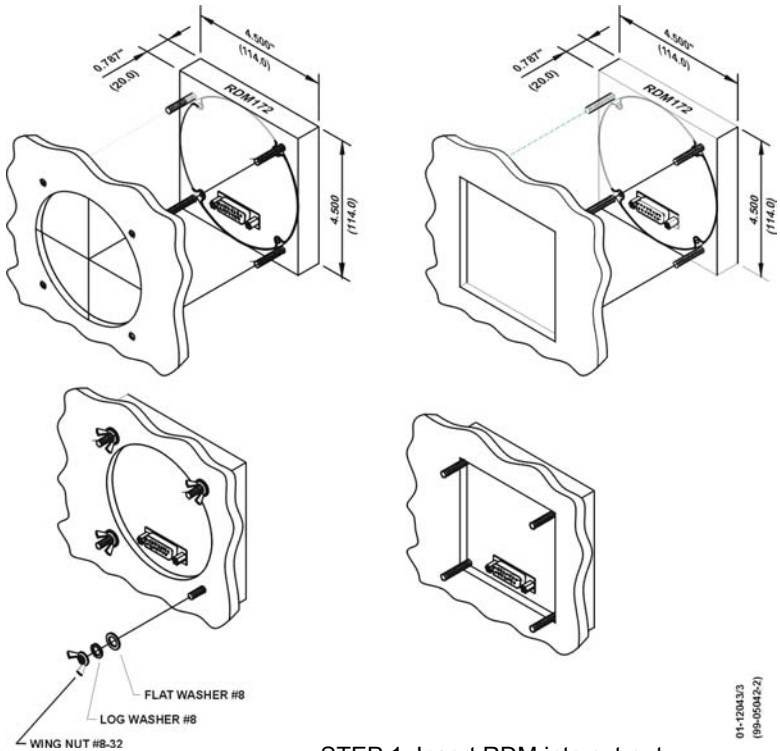

Figure 1-2 RDM172 Mounting

STEP 1: Insert RDM into cut-out.
STEP 2: Fasten washers and nut on screws.

1.2 Special Cutouts

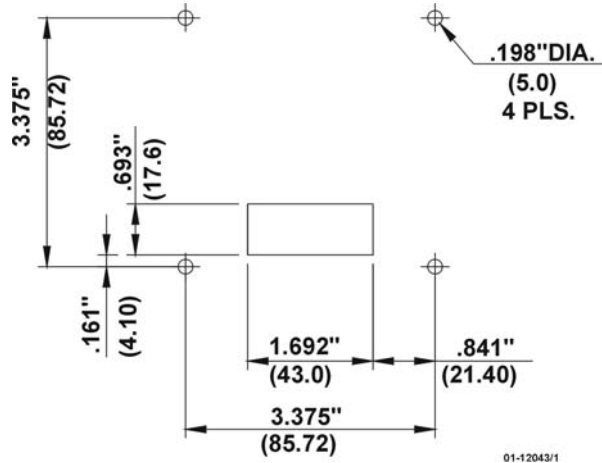

Figure 1-3 Panel Cutout Dimensions

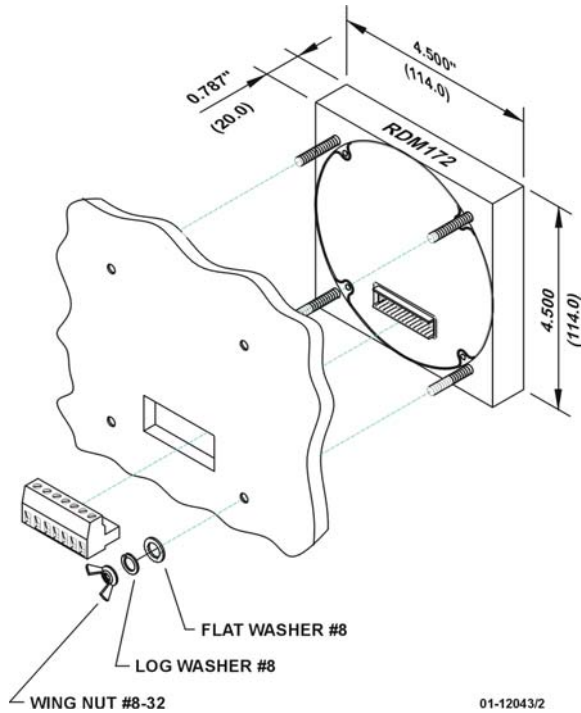

Figure 1-4 RDM172 Mounting

3 Setup on the RDM

3.1 Instrument Setup Menus

Following is a list of instrument setups menus available from the *RDM*.

Instrument Menu	Access from the <i>RDM</i>
Basic	yes
Communication ports	yes
User selectable options	yes
Analog output, analog expander	-
Digital inputs	yes
Timer	yes
Alarm/Event set points	yes
Pulsing output, pulse counter	yes
Log memory partitions	-
Real time clock	yes
Instrument display	-

For full setup instructions for these parameters, see the complete *PM172 Installation and Operation Manual*.

3.2 Performing RDM Communication Adjustment

SELECT → **CHG** → **ENTER** **▲** **▼** → **diSP** → **ENTER**

Press **SELECT** to activate middle window. Press **▲▼**, and scroll to **Addr**.

Press **SELECT** to activate the lower window. Set the instrument address value and press **ENTER** to save the selected value.

Press **▲▼**, and scroll to **bAud**. Press **SELECT** to activate the lower window. Set the baud rate value and press **ENTER** to save the selected value.

3.3 RDM Setup Menu

SELECT → **CHG** → **ENTER** **▲** **▼** → **diSP** → **ENTER**

This menu allows you to view and change RDM properties. Table 1-1 lists available options with their code names and applicable ranges.

Table 3-1 RDM Options (* default setting)

Display	Code	Parameter	Options	Description
<div style="border: 1px solid black; padding: 2px; margin-bottom: 2px;">diSP</div> <div style="border: 1px solid black; padding: 2px; margin-bottom: 2px;">UPdt</div> <div style="border: 1px solid black; padding: 2px;">0.5</div>	UPdt	Display update time	0.1 - 10.0 s (0.5)*	Defines interval between display updates
<div style="border: 1px solid black; padding: 2px; margin-bottom: 2px;">diSP</div> <div style="border: 1px solid black; padding: 2px; margin-bottom: 2px;">ScrL</div> <div style="border: 1px solid black; padding: 2px;">5</div>	ScrL	Auto scroll	nonE* 2-15 s	Disables/enables auto scroll on common measurements display (main screen) and defines scroll interval
<div style="border: 1px solid black; padding: 2px; margin-bottom: 2px;">diSP</div> <div style="border: 1px solid black; padding: 2px; margin-bottom: 2px;">rEtn</div> <div style="border: 1px solid black; padding: 2px;">diS</div>	rEtn	Auto return to the main screen	diS*, En	Disables/enables auto return to the main screen after 30 seconds of uninterrupted use
<div style="border: 1px solid black; padding: 2px; margin-bottom: 2px;">diSP</div> <div style="border: 1px solid black; padding: 2px; margin-bottom: 2px;">VoLt</div> <div style="border: 1px solid black; padding: 2px;">Pri</div>	VoLt	Primary or secondary voltage view	Pri*, SEc	Defines primary or secondary voltage to show.
<div style="border: 1px solid black; padding: 2px; margin-bottom: 2px;">diSP</div> <div style="border: 1px solid black; padding: 2px; margin-bottom: 2px;">Ph.P</div> <div style="border: 1px solid black; padding: 2px;">diS</div>	Ph.P	Phase powers display mode	diS*, En	Disables/enables display of phase powers in common measurements (main screen)
<div style="border: 1px solid black; padding: 2px; margin-bottom: 2px;">diSP</div> <div style="border: 1px solid black; padding: 2px; margin-bottom: 2px;">Fund.</div> <div style="border: 1px solid black; padding: 2px;">diS</div>	Fund.	Fundamental values display mode	diS*, En	Disables/enables display of fundamental values in common measurements (main screen)
<div style="border: 1px solid black; padding: 2px; margin-bottom: 2px;">diSP</div> <div style="border: 1px solid black; padding: 2px; margin-bottom: 2px;">dAtE</div> <div style="border: 1px solid black; padding: 2px;">ndY</div>	dAtE	Date format	ndY* dnY Ynd	Defines the date format in the RTC display: d=day, n=month, Y=year Each date format character is set separately.
<div style="border: 1px solid black; padding: 2px; margin-bottom: 2px;">diSP</div> <div style="border: 1px solid black; padding: 2px; margin-bottom: 2px;">Addr</div> <div style="border: 1px solid black; padding: 2px;">1</div>	Addr	Instrument address	1*-247	

Display	Code	Parameter	Options	Description
<div style="border: 1px solid black; padding: 2px; margin-bottom: 2px;">diSP</div> <div style="border: 1px solid black; padding: 2px; margin-bottom: 2px;">bAud</div> <div style="border: 1px solid black; padding: 2px;">19.2</div>	bAud	Baud rate	2400, 4800, 9600, 19200*	
<div style="border: 1px solid black; padding: 2px; margin-bottom: 2px;">diSP</div> <div style="border: 1px solid black; padding: 2px; margin-bottom: 2px;">dAtA</div> <div style="border: 1px solid black; padding: 2px;">8n</div>	dAtA	Data format	8n*(8 bits, no parity)	

4 Status Information Menu

Table 4-1 lists the displays available from the RDM *Status Information Menu*. The display windows are labeled in the table as follows: 1=upper window, 2=middle window, 3=lower window.

Table 4-1

Page	Window	Parameter	Digits	Unit
1	1	PHAS.		Label
1	2	rOt.		Label
1	3	Phase rotation (POS/NEG/ERR)	4	
2	1	rEL.		Label
2	2	1.2.		Label
2	3	Relay status #1-#2	2	
3	1	St.In		Label
3	2	1.2.		Label
3	3	Status inputs #1-#2	2	
4	1	Cnt.1		Label
4	3	Counter #1	6	
5	1	Cnt.2		Label
5	3	Counter #2	6	
6	1	Cnt.3		Label
6	3	Counter #3	6	
7	1	Cnt.4		Label
7	3	Counter #4	6	
8	1	bAtt		Label
8	3	The battery status (NORMAL/LOW)		

5 Troubleshooting: Fault Condition Display

The RDM172 fault condition screen provides an indication of communication problems, should any occur.

Reasons for a communication fault could be:

- Instrument switched off
- Communication cable disconnected
- Instrument communication setup changed
- RDM172 communication setup changed

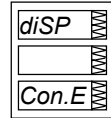

Press **ENTER** to check or alter the RDM172 adjustment and scroll to communication options.

6 Communications

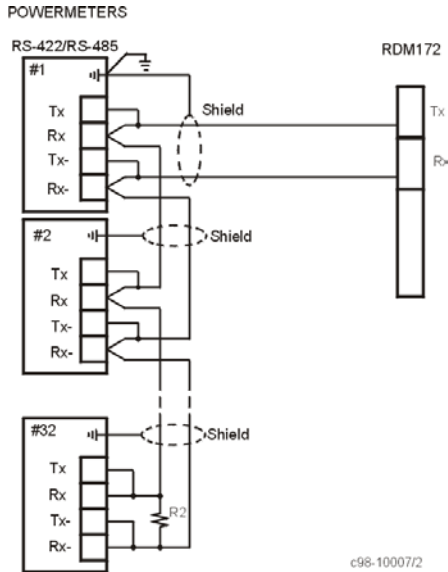

NOTE

Where an RS-232/RS-422 converter is used, R1 is not applicable since it is built in to the converter.

Use a shielded, 0.33 mm²/22 AWG twisted pair cable for each communication link; terminate the ends of multi-drop line with 200-500 Ohm resistors. Connect the cable shield to the ground input.