

**C192PF8**  
**Power  
Factor  
Manager**

**Installation  
and Operation  
Manual**

BG0284 Rev. A5

**SATEC**  

---

# **C192PF8**

## ***Power Factor Manager***



## **Installation and Operation Manual**

## LIMITED WARRANTY

The manufacturer offers the customer an 24-month functional warranty on the instrument for faulty workmanship or parts from date of dispatch from the distributor. In all cases, this warranty is valid for 36 months from the date of production. This warranty is on a return to factory basis.

The manufacturer does not accept liability for any damage caused by instrument malfunction. The manufacturer accepts no responsibility for the suitability of the instrument to the application for which it was purchased.

Failure to install, set up or operate the instrument according to the instructions herein will void the warranty.

Your instrument may be opened only by a duly authorized representative of the manufacturer. The unit should only be opened in a fully anti-static environment. Failure to do so may damage the electronic components and will void the warranty.



## NOTE

The greatest care has been taken to manufacture and calibrate your instrument. However, these instructions do not cover all possible contingencies that may arise during installation, operation or maintenance, and all details and variations of this equipment are not covered by these instructions.

For additional information regarding installation, operation or maintenance of this instrument, contact the manufacturer or your local representative or distributor.

## IMPORTANT

**Please read the instructions this manual before performing installation, and take note of the following precautions:**

-  **Ensure that all incoming AC power and other power sources are turned OFF before performing any work on the instrument. Failure to do so may result in serious or even fatal injury and/or equipment damage.**
-  **Before** connecting the instrument to the power source, check the labels on the side of the instrument to ensure that your instrument is equipped with the appropriate power supply voltage, input voltages, currents and communication protocol for your application.

- ☞ **Under** no circumstances should the instrument be connected to a power source if it is damaged.
- ☞ **To prevent** potential fire or shock hazard, do not expose the instrument to rain or moisture.
- ☞ **The secondary** of an external current transformer must never be allowed to be open circuit when the primary is energized. An open circuit can cause high voltages, possibly resulting in equipment damage, fire and even serious or fatal injury. Ensure that the current transformer wiring is made through shorting switches and is secured using an external strain relief to reduce mechanical strain on the screw terminals, if necessary.
- ☞ **Setup** procedures must be performed only by qualified personnel familiar with the instrument and its associated electrical equipment.
- ☞ **DO NOT open the instrument under any circumstances.**

Modbus is a trademark of Modicon, Inc.

☞ **Read this manual thoroughly before connecting the meter to the current carrying circuits. During operation of the meter, hazardous voltages are present on input terminals. Failure to observe precautions can result in serious or even fatal injury or damage to equipment.**

# Table of Contents

<b>Chapter 1 Introduction.....</b>	<b>1</b>
1.1 About This Manual .....	1
1.2 About The C192PF8 .....	1
<b>Chapter 2 Installation .....</b>	<b>7</b>
2.1 Mechanical Installation .....	7
2.2 Electrical Installation .....	8
<b>Chapter 3 Using The Menus.....</b>	<b>18</b>
<b>Chapter 4 Setup Menus .....</b>	<b>20</b>
4.1 Basic Setup Menu .....	20
4.2 Communications Port Setup Menu.....	22
4.3 Digital Input Setup Menu .....	23
4.4 Analog Output Setup Menu .....	24
4.5 Pulsing Output Setup Menu .....	26
4.6 Alarm/Event Setpoints Setup Menu.....	27
4.7 Relay Operation Control Menu .....	33
4.8 Display Setup Menu .....	34
4.9 User Selectable Options Menu.....	35
4.10 Access Control Menu.....	37
4.11 Reset/Synchronization Menu .....	38
4.12 Manual Relay Control Menu .....	39
4.13 PFC Setup Menu.....	40
4.14 PFC Manual Mode Menu .....	43
<b>Chapter 5 PFC Setup and Operation .....</b>	<b>45</b>
5.1 Capacitor Bank Control Options.....	45
5.2 PFC Operation .....	46
5.3 Capacitor Banks Protection .....	53
<b>Chapter 6 Data Display.....</b>	<b>56</b>
6.1 Navigating in the Display Mode .....	56
6.2 Data Display Formats.....	59
6.3 Self-Test Diagnostics Display .....	63
<b>Chapter 7 Viewing Status Information.....</b>	<b>64</b>
7.1 The Status Information Menu .....	64
7.2 Status Display Formats.....	65
<b>Appendix: Technical Specifications.....</b>	<b>67</b>

# Chapter 1 Introduction

## 1.1 About This Manual

This manual is intended for the user of the *C192PF8* Power Factor Manager. The *C192PF8* is a multi-function microprocessor-based instrument used for power factor correction and for the measurement, monitoring, and management of electrical parameters in low-voltage and mid-voltage power systems.

This chapter gives an overview of this manual and an introduction to the *C192PF8*.

Chapter 2, *Installation*, provides instructions for mechanical and electrical installation.

Chapter 3, *Using the Menus*, presents the structure of menus for setup and status viewing.

Chapter 4, *Setup Menus*, provides instructions for performing parameter setup via the front panel.

Chapter 5, *PFC Setup and Operation*, provides instructions for performing setup for the Power Factor Controller (PFC) and describes front-panel operations in PFC manual mode.

Chapter 6, *Data Display*, guides you through the display pages.

Chapter 7, *Viewing Status Information*, tells you how to access additional status information on the instrument. This information may be useful during installation.

*Technical Specifications* for the *C192PF8* are found in the Appendix.

## 1.2 About The *C192PF8*

The *C192PF8* is a compact three-phase AC Powermeter with a built-in Power Factor Controller (PFC), designed to meet the requirements of users ranging from electrical panel builders to substation operators. The *C192PF8* performs power factor correction functions, basic voltage, current, frequency, power, power factor and energy measurements, plus total harmonic (THD, TDD, K-Factor) measurements.

The *C192PF8* is suitable for mounting on 136×136 mm square cut-outs.

## Features

### **Power Factor Controller**

- Control of up to 8 capacitor banks
- Manual, self-adapting automatic and optimizing automatic operation
- Full four-quadrant operation
- Two power factor setpoint ranges for day and night operations selectable via a status input
- Target power factor range from 0.5 (inductive) to -0.5 (capacitive)
- True and displacement power factor setups
- Extensive capacitor banks protection via programmable alarm setpoints (no-volt, over-voltage and high harmonics override conditions)

### **Display**

The front panel features bright LED displays (three windows, up to 43 pages) with adjustable display update time. Display auto scroll is available on the main screen with a programmable scroll interval of 2 to 15 seconds. Automatic return to the main screen is available after 30 seconds of uninterrupted use. The front panel also includes:

- **Relay status bar** showing output status of the 8 relays
- **Alarm/Manual Mode** LED providing a local indication when a predefined alarm condition appears (the LED is lit constantly) or when the PFC operates in Manual Mode (the LED flashes). The alarm LED is shut off manually (by pressing on both up and down keys for more than 5 sec)
- **RXD/TXD** LEDs showing communications receive/transmit status

**Setup** is menu driven, with optional password protection. 16 programmable setups are provided for alarm and control functions (for programmable parameters, see 'Measured Parameters' below).

**Communications** are available using an RS-232 or RS-485 standard (factory set), with ASCII/Modbus protocols. 120 user assignable registers are available in ASCII/Modbus protocols.

**Eight relays** are provided for capacitor banks switching, energy pulsing (KYZ) or alarm and remote control. Contacts of six relays may switch loads up to 250V, 5A AC and are recommended for alarm and remote control; contacts of two relays may switch loads up to 250V, 3A AC and may be used for energy pulsing.

**One optically isolated analog output** is provided for remote monitoring or control. Current loop options are 0-20 and 4-20 mA. The analog output must be used with an external power supply.

**Four common-use event/time counters** are provided for counting user-defined events or their duration. These can be used for counting total operation time of generators or overload time of transformers or power lines. The counters are operated and released by user-defined triggers.

**Eight dedicated relay operation (switching cycle) counters** are provided for counting the number of PFC relay operations (number of complete switching cycles).

**One digital input** can be used as a **status** input for monitoring external contacts or as an **external synchronization** input for power demand interval synchronization. When no external synchronization pulse is provided, the power demand interval can be synchronized through communications.

**Three user-selectable options** are provided:

**Power calculation mode**

Power calculations can be made using directly measured reactive power or through non-active power based on direct apparent power measurements.

**Energy rollover value**

This option specifies the point at which the energy value rolls over to zero.

**Phase energy calculations mode**

This option is used to enable or disable phase energy calculations.

## Measured Parameters

Note: Real-time values are measured over 1 cycle of fundamental frequency; Average values are sliding average of 8, 16 or 32 real-time measurements.

Parameter	Dis-play	Com	Output		
			Analog	Pulse	Alarm
<b>Average Amps, Volts, Frequency</b>			\$ = setup via PC # = setup via panel		
Average RMS voltage per phase L-N	√	√	#\$		#\$
Average RMS voltage per phase L-L ①	√	√	①		①
Average RMS current per phase	√	√	#\$		#\$
Average frequency	√	√	#\$		#\$
Average neutral current	√	√	#\$		#\$
Voltage & current unbalance	√	√			
<b>Amps &amp; Volt Demand Parameters</b>					
Ampere demand per phase		√			#\$
Volt demand per phase		√			#\$
Ampere maximum demand per phase	√	√			
Voltage maximum demand per phase	√	√			

Parameter	Dis-play	Com	Output		
			Analog	Pulse	Alarm
<b>Average Power Values</b>					
Average active power per phase	√	√			
Average reactive power per phase	√	√			
Average apparent power per phase	√	√			
Average total active power	√	√	#\$		#\$
Average total reactive power	√	√	#\$		#\$
Average total apparent power	√	√	#\$		#\$
Average power factor per phase	√	√			
Average total power factor	√	√	#\$		#\$
<b>Power Demand Parameters</b>					
Active power accumulated demand		√	#\$		#\$
Apparent power accumulated demand		√	#\$		#\$
Active power demand		√			#\$
Active power sliding demand		√			#\$
Apparent power demand		√			#\$
Apparent power sliding demand		√			#\$
Active power predicted demand		√			#\$
Apparent power predicted demand		√			#\$
Active power maximum demand	√	√			
Apparent power maximum demand	√	√			
<b>Energy Per Phase</b>					
Active energy import per phase	√	√			
Reactive energy import per phase	√	√			
Apparent energy per phase	√	√			
<b>Total Energy</b>					
Total active energy import	√	√		#\$	
Total active energy export	√	√		#\$	
Total reactive energy import	√	√		#\$	
Total reactive energy export	√	√		#\$	
Total reactive energy net		√			
Total reactive energy absolute				#\$	
Total apparent energy	√	√		#\$	
<b>Min/Max Log</b>					
Min/Max volts	√	√			
Min/Max amps, neutral current	√	√			
Min/Max frequency	√	√			
Min/Max kW, kvar, kVA, PF	√	√			
<b>Real-time Amps, Volts, Frequency</b>					
RT RMS voltage per phase L-N		√	#\$		#\$
RT RMS voltage per phase L-L ①		√	①		①

Parameter	Dis-play	Com	Output		
			Analog	Pulse	Alarm
RT RMS current per phase		√	#\$		#\$
RT frequency		√	#\$		#\$
RT neutral current		√			
<b>Real-time Power Values</b>					
RT active power per phase		√			
RT reactive power per phase		√			
RT apparent power per phase		√			
RT total active power		√	#\$		
RT total reactive power		√	#\$		
RT total apparent power		√	#\$		
RT power factor per phase		√			
RT total power factor		√	#\$		
<b>Real-time Harmonic Values</b>					
RT voltage THD per phase		√			#\$
RT current THD per phase		√			#\$
RT current TDD per phase		√			#\$
RT K-Factor per phase		√			#\$
<b>Average Harmonic Values</b>					
Average Voltage THD per phase	√	√			
Average Current THD per phase	√	√			
Average Current TDD per phase	√	√			
Average K-Factor per phase	√	√			
<b>Fundamental Frequency Values (H01)</b>					
Voltage & current per phase		√			
kW, PF per phase	√	√			
kvar, kVA per phase		√			
Total kW, PF	√	√			
Total kvar, kVA		√			
<b>Phase Rotation</b>	√				#\$
<b>Counters</b>	√	√			
<b>Status Input</b>	√	√			#\$
<b>Relay Status</b>	√	√			
<b>Remote Relay Control</b>		√			
<b>Alarm Trigger Status</b>		√			#\$
<b>Self-Diagnostic Tests</b>	√	√			

① For **4Ln3** and **3Ln3** wiring configurations line to line and line to neutral voltages are displayed and transmitted via communication simultaneously and can be used as triggers for alarm set points; analog output uses **line to neutral** voltages. For other configurations only **line to line** voltages are used.

# Instrument Dimensions

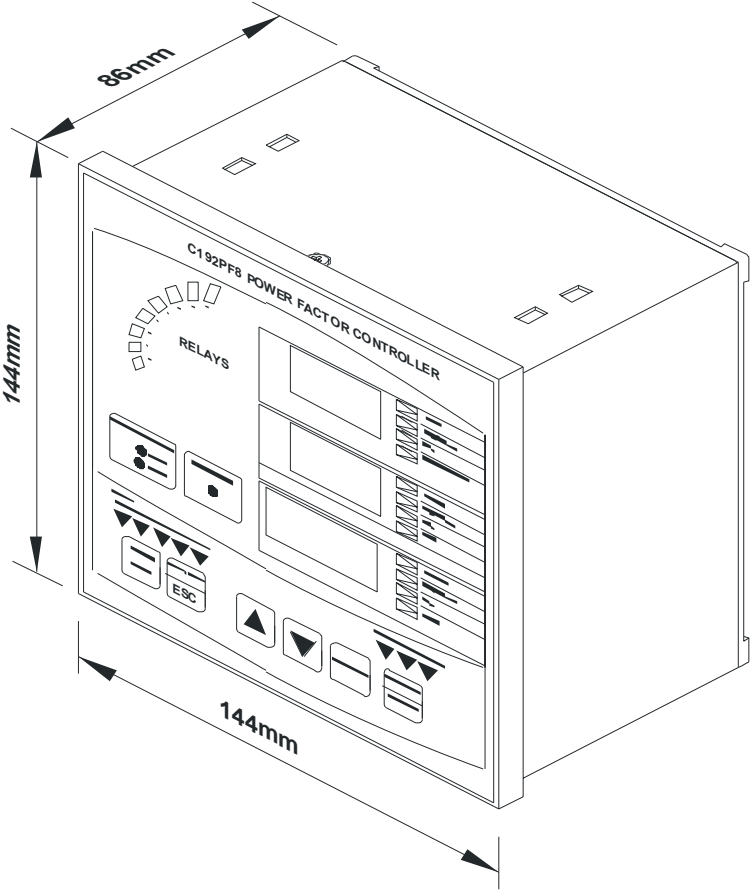

Figure 1-1 C192PF8 Dimensions

# Chapter 2 Installation

## 2.1 Mechanical Installation

Prepare the panel cut-out, 136 x 136 mm, prior to mounting.

STEP 1: Place the instrument through the cut-out.

STEP 2: Assemble the latches onto the outer wall of the enclosure.

STEP 3: Tighten the screws.

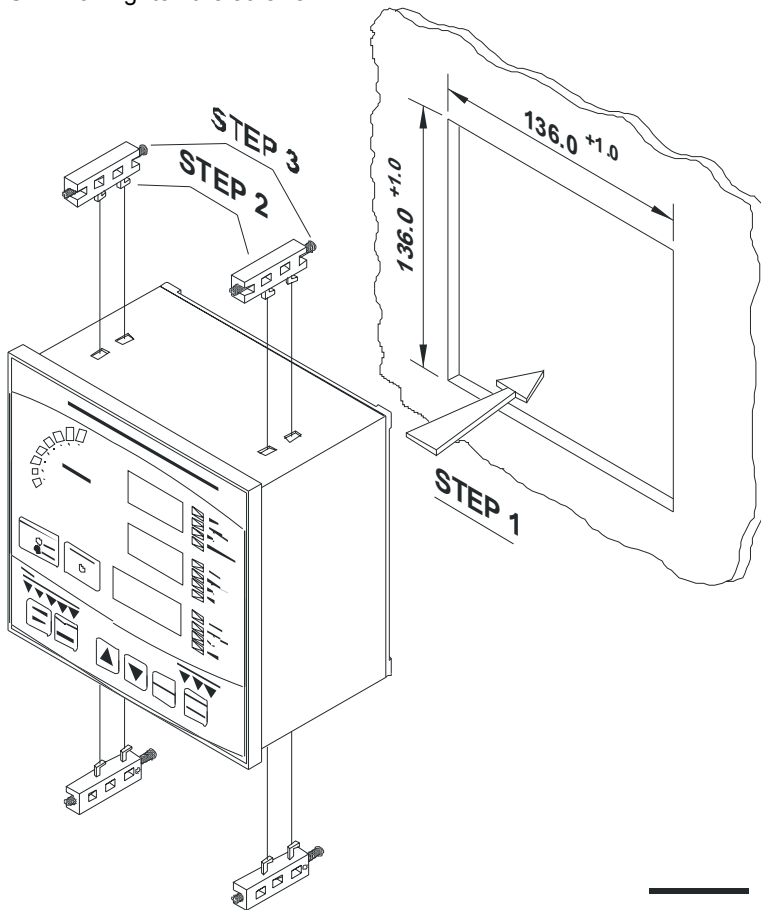

**Figure 2-1** Mounting the C192PF8

## 2.2 Electrical Installation

 Before installation ensure that all incoming power sources are shut OFF. Failure to observe this practice can result in serious or even fatal injury and damage to equipment.

Connections to the *C192PF8* are made via terminals (voltage and current inputs, power supply, communication, relay and analog output) as shown in Figure 2-2.

### 2.2.1 Power Supply Connection

The power supply can be dedicated-fused, or from a monitored voltage if it is within the instrument's power supply range. Use an external circuit breaker or switch.

AC power supply: line to terminal 12; neutral to terminal 10.

DC power supply: positive to terminal 12; negative to terminal 10.

### 2.2.2 Current Inputs

Connect the current inputs to terminals 1, 3, 4, 6, 7, and 9. The instrument is connected to the current transformer as shown in *Figures 2-3 through 2-10*.

### 2.2.3 Ground

Connect the chassis ground *C192PF8* terminal to the switchgear earth ground using dedicated wire of greater than 2.5 mm<sup>2</sup>/13 AWG.

### 2.2.4 Voltage Inputs

Connect the voltage inputs to terminals 2, 5, 8 and 11. For 690V input, use any of the eight wiring configurations shown in *Figures 2-3 through 2-10*.

For 120V input, use any of the four wiring configurations shown in *Figures 2-5 through 2-8*.

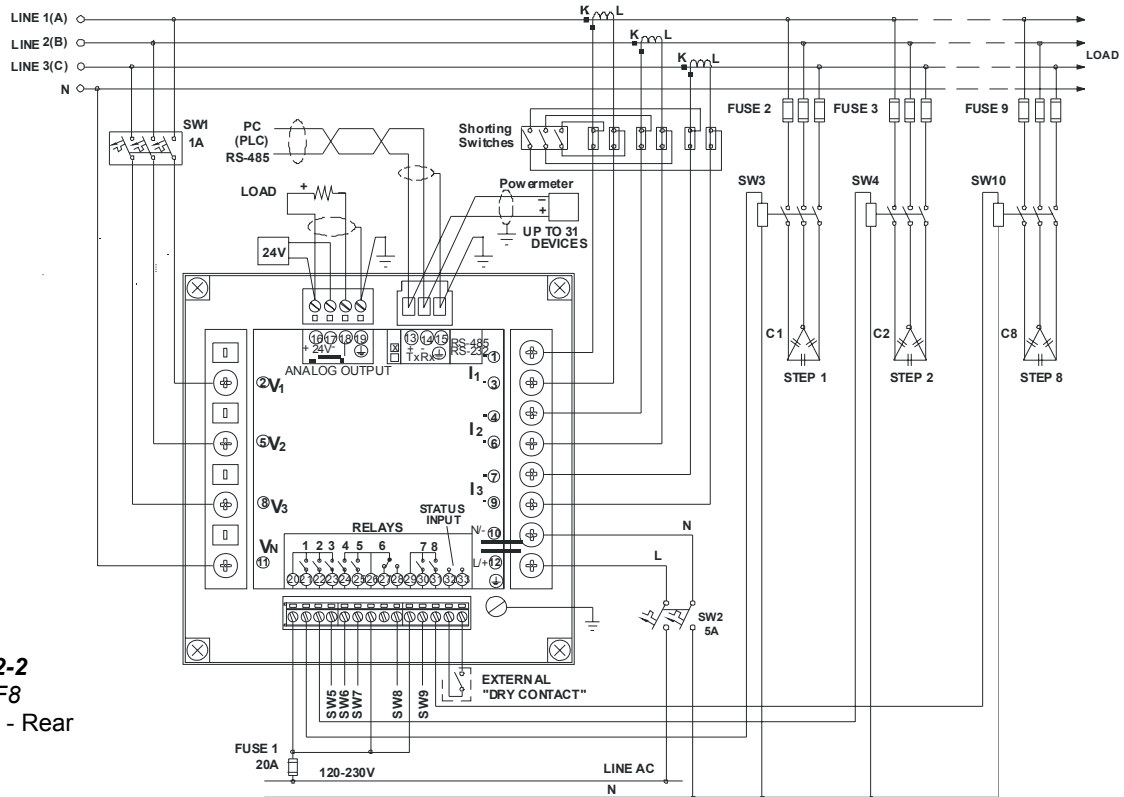

**Figure 2-2**  
**C192PF8**  
 Connections - Rear  
 View

## 2.2.5 Wiring Configurations

Wiring Configuration (See parameter setup instructions in Section 4.1)	Wiring	
	Setup Mode	Connection
3-wire direct connection using 2 CTs (2-element)	3dir2	Figure 2-3
4-wire WYE direct connection using 3 CTs (3-element)	4Ln3 or 4LL3	Figure 2-4
4-wire WYE connection using 3 PTs, 3 CTs (3-element)	4Ln3 or 4LL3	Figure 2-5
3-wire open delta connection using 2 PTs, 2 CTs (2-element)	3OP2	Figure 2-6
3-wire open delta connection using 2 PTs, 3 CTs (2½ element)	3OP3	Figure 2-7
4-wire WYE connection using 2 PTs, 3 CTs (2½-element)	3Ln3 or 3LL3	Figure 2-8
4-wire delta direct connection using 3 CTs (3-element)	4Ln3 or 4LL3	Figure 2-9
3-wire/4-wire connection using the current from one phase (1 CT) and the L-L voltage from the other two phases	2LL1	Figure 2-10

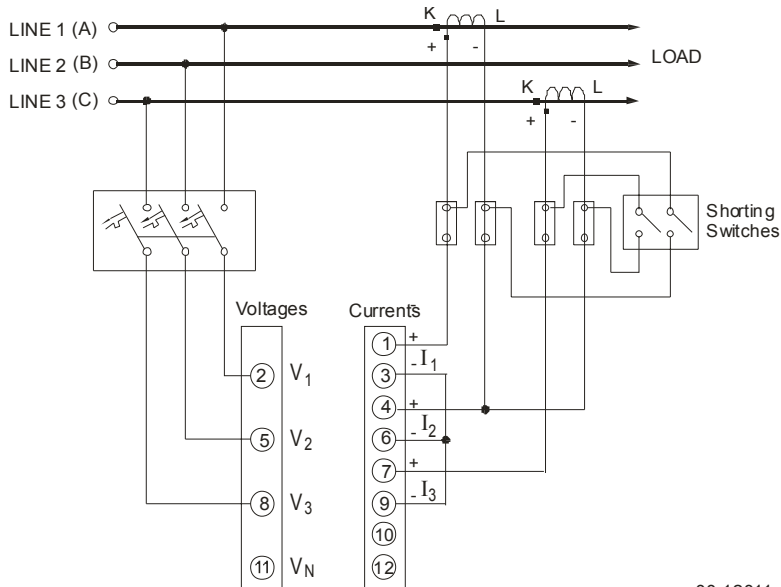

c00-12011

**Figure 2-3**  
Three Wire Direct Connection Using 2 CTs (2-element)  
Wiring Mode = **3dir2**

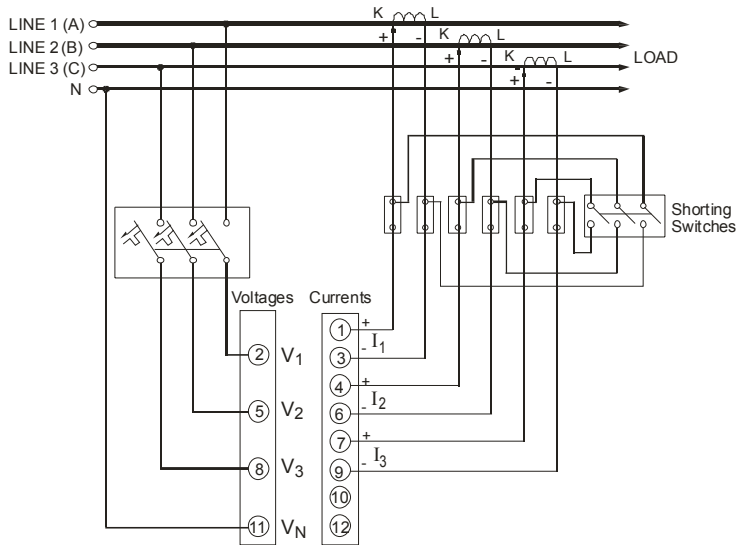

99-09036

**Figure 2-4**  
 Four Wire WYE Direct Connection Using 3 CTs (3-element)  
 Wiring Mode = **4LL3** or **4Ln3**

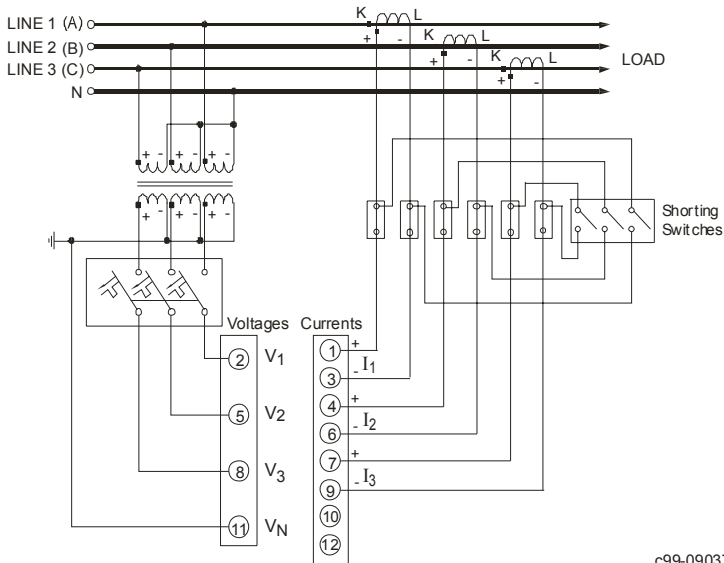

c99-09037

**Figure 2-5**  
 Four Wire WYE Connection Using 3 PTs, 3 CTs (3-element)  
 Wiring Mode = **4LL3** or **4Ln3**

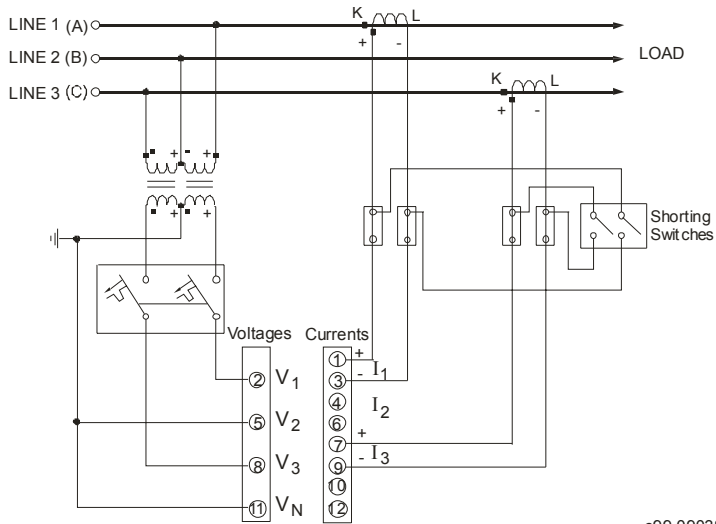

c99-09038

**Figure 2-6**  
 Three Wire Open Delta Connection Using 2 PTs, 2 CTs (2-element)  
 Wiring Mode = 3OP2

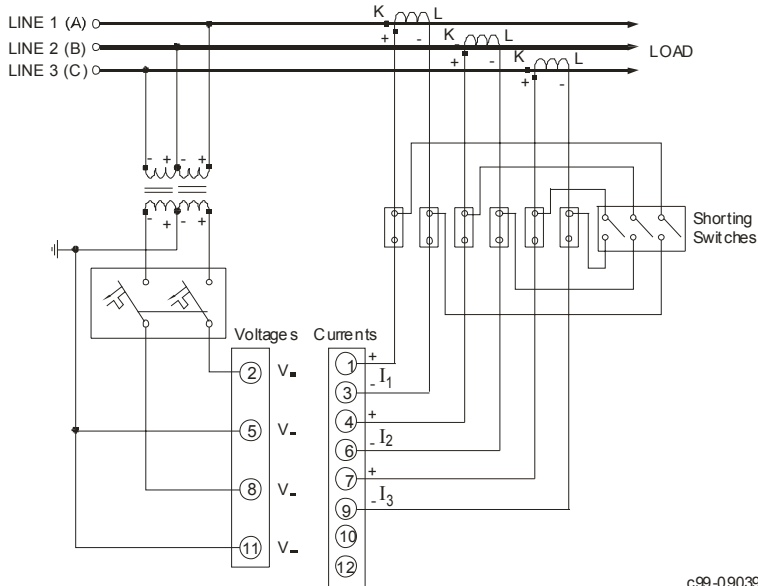

c99-09039

**Figure 2-7**  
 Three Wire Open Delta Connection Using 2 PTs, 3 CTs (2½-element)  
 Wiring Mode = 3OP3

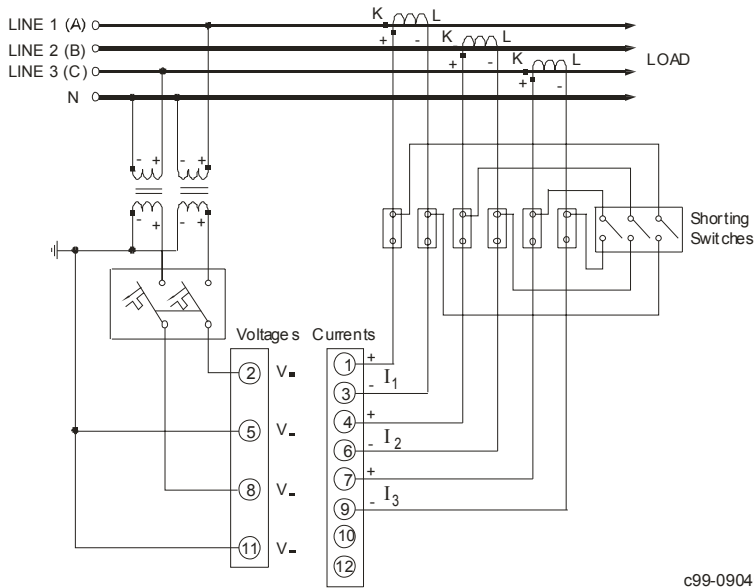

c99-09040

**Figure 2-8**  
 Four Wire WYE Connection Using 2 PTs, 3 CTs (2½ element)  
 Wiring Mode = 3Ln3 or 3LL3

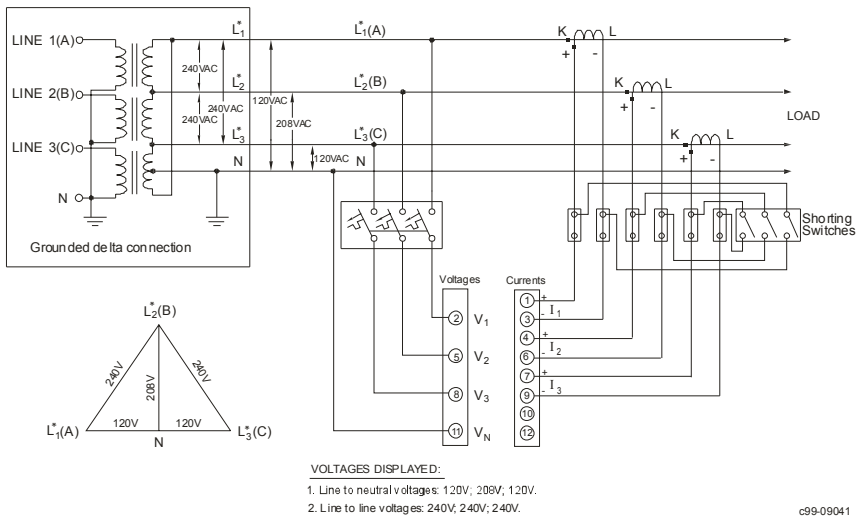

c99-09041

**Figure 2-9**  
 Four Wire Delta Direct Connection Using 3 CTs (3 element)  
 Wiring Mode = 4LL3 or 4Ln3

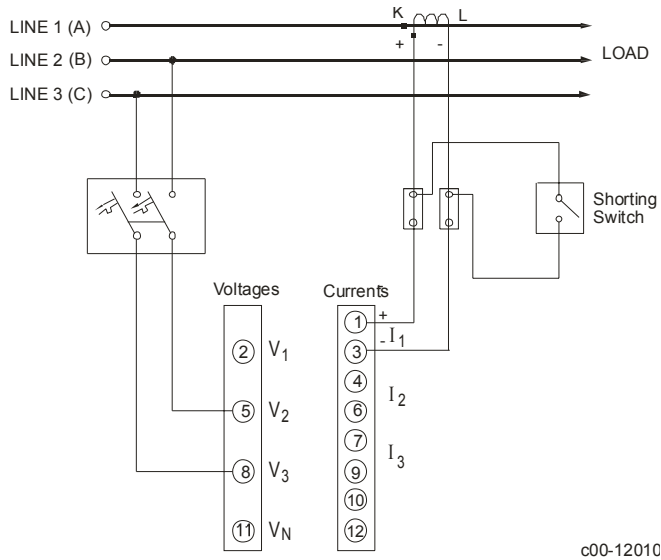

**Figure 2-10**  
Three/Four Wire Direct Connection Using 1 CT Wiring Mode = 2LL1

## 2.2.6 Relays

Eight relays are provided for capacitor bank control (or energy pulsing/alarms).

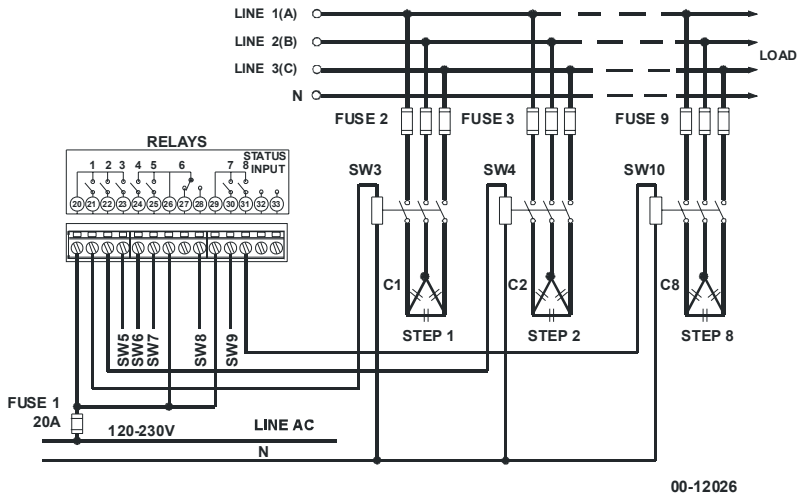

**Figure 2-11** Relays Connection

## 2.2.7 Status Input

One status input is provided for status monitoring or external synchronization input for power demand period.

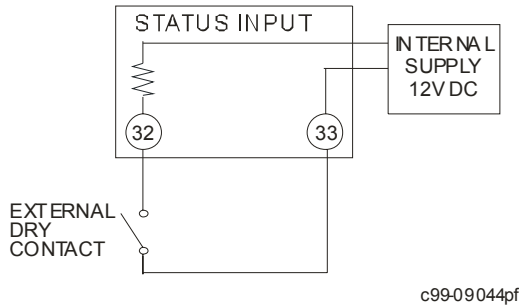

**Figure 2-12** Status Input Connection

## 2.2.8 Analog Output

The C192PF8 provides one optically isolated analog output with current output options of 0-20 mA and 4-20 mA (current loop load of up to 500 Ohm). The analog output must be used with a 24 V DC external power supply.

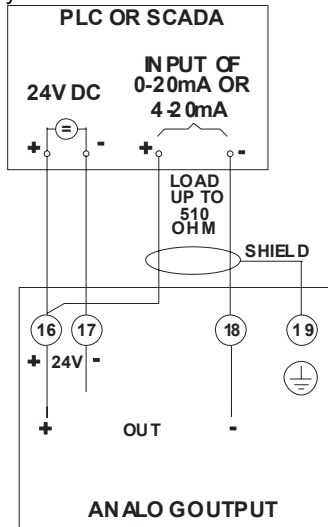

**Figure 2-13** Analog Output Connection

## 2.2.9 Communications

The C192PF8 is provided with an RS-232 or RS-485 communication port. *Figures 2-14 through 2-18* illustrate the connections.

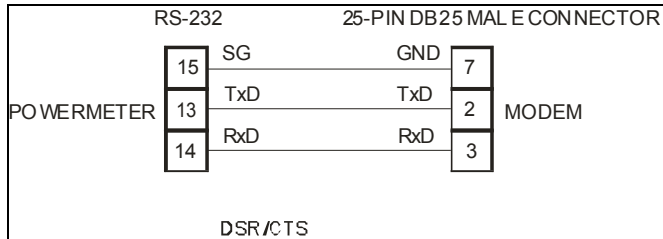

**Figure 2-14** RS-232 Connection for 25-pin Modem Connector

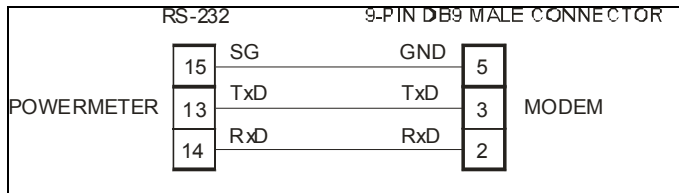

**Figure 2-15** RS-232 Connection for 9-pin Modem Connector

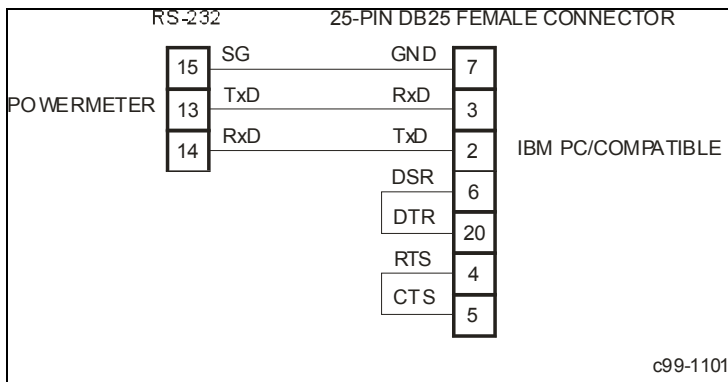

**Figure 2-16** RS-232 Simple 3-Wire Computer Connection, 25-pin

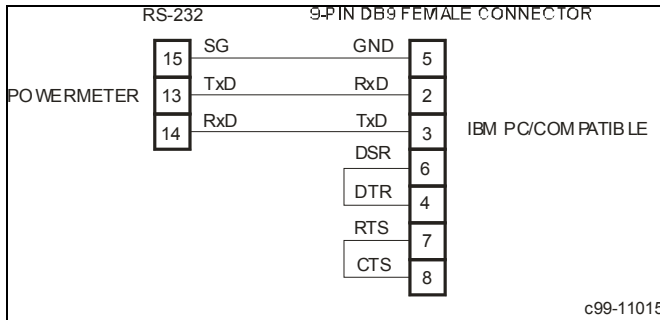

**Figure 2-17** RS-232 Simple 3-Wire Computer Connection, 9-pin

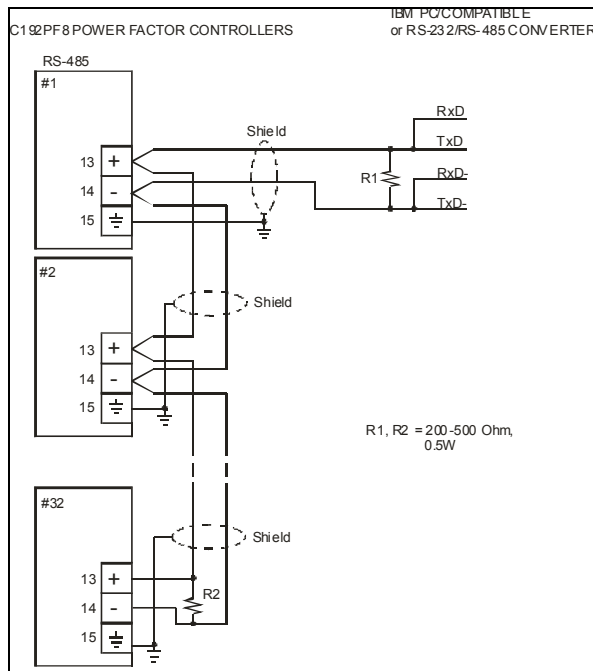

**Figure 2-18** RS-485 Multi-drop Computer Connection

**NOTE:** Where the manufacturer's RS-232/RS-485 converter is used on a computer connection, R1 is not applicable since it is built in to the converter.

Activity on the communications port lines is indicated via the TXD and RXD LEDs, the front panel and via the Status Information menu (see Chapter 7).

A full description of the communication protocols may be found in the *C192PF8 ASCII and Modbus Communications Manuals* provided with your instrument.

# Chapter 3 Using The Menus

Press and release **SELECT** to enter the setup mode. The primary menus will appear:

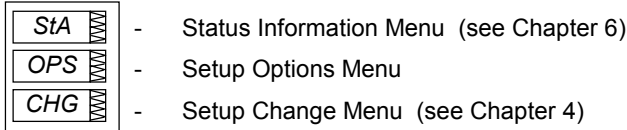

Press **SELECT** again to activate the window of the desired primary menu.

Press **ENTER**.

Select **CHG** to initialize or modify the instrument setup, or to clear the accumulated values stored in the instrument. Entry to this menu can be protected by a password.



Select **StA** to view extended status information which may be useful during installation and in certain applications.



Select **OPS** for viewing (not editing) the instrument setup options.



After selecting either **OPS** or **CHG**, the list of setup menus is displayed in the upper window. Figure 3-1 presents a complete menu list. Depending on the model of your instrument, some menu may not appear.

## Password

The *Setup Change Menu* can be secured by a user-defined password comprised of 4 digits. The instrument is shipped with password protection disabled. To enable password protection, go to the *Access Control Menu* (see Section 4.10).

The *Password Menu* appears if password protection is enabled.

### To enter a password:

- ✓ Set the first digit using the up and down arrow keys.
- ✓ Press **SELECT** to advance to the next digit.
- ✓ Set the other password digits in the same manner.
- ✓ Press **ENTER** to continue setup. If your password is incorrect, you will return to the *Primary Selection Menu*.

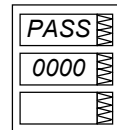

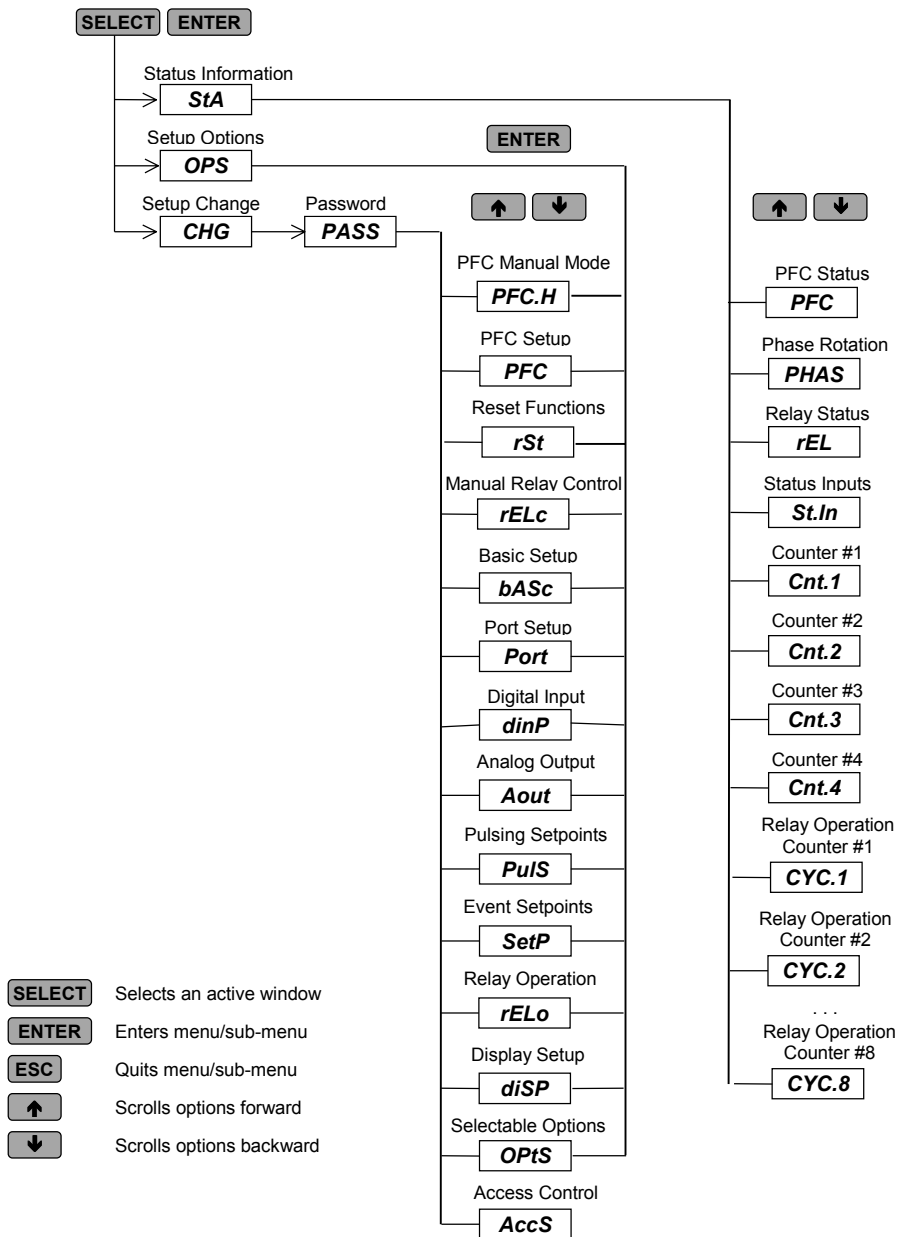

**Figure 3-1** Menu Structure

# Chapter 4 Setup Menus

**NOTE:** Instrument setup can be performed directly on the front panel using the setup menu or via communications using PComTest communication software. PComTest is supplied with your instrument and provides full setup capabilities for your instrument. For information on using PComTest, refer to the user documentation supplied with your instrument.

Setup	Display	PComTest	
Basic	+	+	
Communication port	++	+	
User Selectable options	++	+	
Analog output	+	+	Key:
Digital input	+	+	++ Recommended
Alarm/Event set points	+	+	+ Possible
Pulsing output	+	+	- Not possible
PFC setup	+	++	
Assignable registers	-	++	
Display	++	-	

## 4.1 Basic Setup Menu

**SELECT** → **CHG** → **ENTER** → **bASc** → **ENTER**

This menu contains the basic configuration options which define the general operating characteristics of your instrument, such as wiring mode, input scales, the size of the RMS averaging buffer, etc. Table 4-1 lists the basic setup options, their code names and applicable ranges.

Activate the middle window to scroll through the list of available options, and then activate the lower window to set the option value.

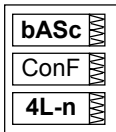

### **To select and view a setup option:**

- ✓ Press **SELECT** to activate the middle window
- ✓ Use the up/down arrow keys to scroll to the desired option. The current value for this option appears in the lower window.

### **To change the value of the selected option:**

- ✓ Press **SELECT** to make the lower window active.
- ✓ Press the up/down arrow keys to scroll to the desired value.
- ✓ Press **ENTER** to store the selected value, or press **ESC** to quit the setup menu.

**Table 4-1 Basic Setup Options (\* default setting)**

Code	Parameter	Options	Description
<i>ConF</i>	Wiring mode	3OP2	3-wire open delta using 2 CTs (2 element)
		4Ln3*	4-wire Wye using 3 PTs (3 element), line to neutral voltage readings
		3dir2	3-wire direct connection using 2 CTs (2 element)
		4LL3	4-wire Wye using 3 PTs (3 element), line to line voltage readings
		3OP3	3-wire open delta using 3 CTs (2½ element)
		3Ln3	4-wire Wye using 2 PTs (2½ element), line to neutral voltage readings
		3LL3	4-wire Wye using 2 PTs (2½ element), line to line voltage readings
		2LL1	3-wire/4-wire connection using the current from one phase (1 CT) and the L-L voltage from the two other phases
<i>Pt</i>	PT ratio	1.0*-6,500.0	The phase potential transformer ratio
<i>Ct</i>	CT primary current	1-6,500A (5000*)	The primary rating of the phase current transformer
<i>d.P</i>	Power demand period	1, 2, 5, 10, 15*, 20, 30, 60, E	The length of the demand period for power demand calculations, in minutes. E=external synchronization ①
<i>n.dp</i>	Number of power demand periods	1-15 (1*)	The number of demand periods to be averaged for sliding window demands 1 = block interval demand calculation
<i>A.dP</i>	Ampere/Volt demand period	0-1800 s (15*)	The length of the demand period for volt/ampere demand calculations 0 = measuring peak current
<i>buF</i>	Averaging buffer size	8*,16,32	The number of measurements for RMS sliding averaging
<i>rSt</i>	Reset enable/disable	diS*, En	Protects all reset functions, both via the front panel or communications.
<i>Freq</i>	Nominal frequency	50, 60 Hz②	The nominal power utility frequency
<i>LoAd</i>	Maximum demand load current	0-6,500A (0*)	The maximum demand load current used in TDD calculations (0 = CT primary current)

① When the power demand period is specified in minutes, synchronization of the demand interval can be made through communications (see the *C192PF8* ASCII/Modbus Reference Guides) or via the front panel (see Section 4.11). If the power demand period is set to External Synchronization, an external synchronization pulse denoting the start of the next demand interval can be provided through a digital input or can be simulated by using the synchronization command sent via communications.

② 60 Hz default for North America; elsewhere, default is 50Hz.

## NOTES

- 1) The maximum value for CT PRIMARY CURRENT × PT RATIO is 10,000,000. If this product is greater, power related values will be zeroed.
- 2) Always specify WIRING MODE, PT RATIO and CT PRIMARY CURRENT prior to setting up alarm setpoints, otherwise the alarm/event setpoints which use these parameters will automatically be disabled.
- 3) You will not be able to change the WIRING MODE, PT RATIO and CT PRIMARY CURRENT when the PFC is operating (see Section 4.13).

## 4.2 Communications Port Setup Menu

**SELECT** → **CHG** → **ENTER**   → **Port** → **ENTER**

This menu allows you to access the communications port options that the *C192PF8* uses to communicate with a master computer. Table 4-2 lists the communications options, their code names and applicable choices.

Activate the middle window to scroll through the list of available options, and then activate the lower window to set the option value.

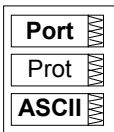

### To select and view a setup option:

- ✓ Press **SELECT** to activate the middle window.
- ✓ Use the up/down arrow keys to scroll to the desired option.  
The option setting will appear in the lower window.

### To change the selected option:

- ✓ Press **SELECT** to activate the lower window.
- ✓ Press the up/down arrow keys to scroll to the desired value.
- ✓ Press **ENTER** to store the selected value or press **ESC** to quit the setup menu.

**Table 4-2 Communications Options** (\* default setting)

Code	Parameter	Options	Description
<i>Prot</i>	Communications protocol	<i>ASCII*</i> <i>rtu</i>	ASCII protocol Modbus RTU protocol
<i>Addr</i>	Address	<i>0*-99 ASCII</i> <i>1*-247 Modbus</i>	Powermeter address
<i>bAud</i>	Baud rate	<i>110</i> <i>300</i> <i>600</i> <i>1200</i> <i>2400</i> <i>4800</i> <i>9600*</i> <i>19.20</i>	110 baud 300 baud 600 baud 1200 baud 2400 baud 4800 baud 9600 baud 19,200 baud

Code	Parameter	Options	Description
dAtA	Data format	7E	7 bits, even parity
		8n*	8 bits, no parity
		8E	8 bits, even parity
CpTb	ASCII compatibility mode	diS*, En	Disables/enables ASCII compatibility mode. For more information, see ASCII Communications Protocol Reference Guide

## 4.3 Digital Input Setup Menu



This menu is used to set up a digital input provided by the C192PF8.

The digital input can be configured as:

- a **status input** to monitor external contact status, or
- an **external synchronization pulse input** to receive an external synchronization pulse indicating the beginning of a new demand interval for power demand measurements.

The setup menu is used for allocating an external synchronization pulse input. If you do not allocate the digital input as an external synchronization input, it is automatically configured as a status input.

External  
synchronization  
input

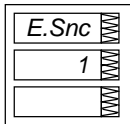

### To change the digital input allocation:

- ✓ Press **SELECT** to activate the middle window.
- ✓ Use the up/down arrow keys to set the input allocation status.
- ✓ Press **ENTER** to store your new inputs allocation.
- ✓ Press **ESC** to leave the allocation unchanged or to quit the menu.

“1” indicates that the input is allocated as the external synchronization pulse input; “0” indicates that the input is allocated as the status input.

### NOTES

1. A digital input configured as the status input can be monitored via the *Status Information Menu* (see Chapter 6) and communications.
2. If the digital input has been allocated as the external synchronization pulse input, synchronization of the demand interval through communications is not available.

## 4.4 Analog Output Setup Menu

[This section is relevant to instruments ordered with this option.]



This menu allows you to set up an output value and its zero and full scales for the internal analog output. Table 4-3 explains the analog output setup options, and Table 4-4 lists all measurement parameters that can be directed to analog output.

Output parameter      Zero-scale output      Full-scale output

Aout
Outp
rt U1

Aout
Lo
0

Aout
Hi
828

### **To view the setup options for the analog output:**

- ✓ Press **SELECT** to activate the middle window.
- ✓ Use the up/down arrow keys to scroll to the desired option. The value associated with this option is displayed in the lower window.

### **To change the setup options for the selected channel:**

- ✓ Press **SELECT** to activate the lower window.
- ✓ Use the up/down arrow keys to scroll to the desired value.
- ✓ Press **ENTER** to store the selected value, or press **ESC** to leave the value unchanged.
- ✓ Press **ENTER** again to store the setup for the channel.

### **To quit the setup without changes:**

- ✓ From the middle or lower window, press **ESC**.

### **To quit the menu:**

- ✓ From the upper window, press **ESC** or **ENTER**.

## NOTES

1. Except for the signed power factor, the output scale is linear within the value range. The scale range will be inverted if the full scale specified is less than the zero scale.
2. The output scale for the signed power factor is symmetrical with regard to  $\pm 1.000$  and is linear from  $-0$  to  $-1.000$ , and from  $1.000$  to  $+0$  (note that  $-1.000 \equiv +1.000$ ). Negative power factor is output as  $[-1.000 \text{ minus measured value}]$ , and non-negative power factor is output as  $[+1.000 \text{ minus measured value}]$ . To define the entire power factor range from  $-0$  to  $+0$ , the scales would be specified as  $-0.000/0.000$ .
3. Each time you select the output parameter for the analog channel, its zero and full scales are set by default to the lower and upper parameter limits, respectively.

**Table 4-3 Analog Output Setup Options**

Code	Option	Description
<i>OutP</i>	Output parameter	The output parameter for the analog output channel
<i>Lo</i>	Zero scale (0/4 mA)	The reading of the parameter corresponding to a zero-scale current output
<i>Hi</i>	Full scale (1/20 mA)	The reading of the parameter corresponding to a full-scale current output

**Table 4-4 Analog Output Parameters**

Code	Parameter	Uni	Scale
nonE	Output disabled		0
<b>Real-time Measurements</b>			
<i>r. U 1</i>	Voltage L1/L12	V/kV	0 to Vmax
<i>r. U 2</i>	Voltage L2/L23	V/kV	0 to Vmax
<i>r. U 3</i>	Voltage L3/L31	V/kV	0 to Vmax
<i>r. C1</i>	Current L1	A	0 to I <sub>max</sub>
<i>r. C2</i>	Current L2	A	0 to I <sub>max</sub>
<i>r. C3</i>	Current L3	A	0 to I <sub>max</sub>
<i>r. P</i>	Total kW	kW/MW	-P <sub>max</sub> to P <sub>max</sub>
<i>r. q</i>	Total kvar	kvar/Mvar	-P <sub>max</sub> to P <sub>max</sub>
<i>r. S</i>	Total kVA	kVA/MVA	0 to P <sub>max</sub>
<i>r. PF</i>	Total PF		-0.000 to 0.000
<i>r. PF.LG</i>	Total PF lag		0 to 1.000
<i>r. PF.Ld</i>	Total PF lead		0 to 1.000
<i>r. Fr</i>	Frequency ①	Hz	0 to 100.00
<b>Average Measurements</b>			
<i>A. U 1</i>	Voltage L1/L12	V/kV	0 to Vmax
<i>A. U 2</i>	Voltage L2/L23	V/kV	0 to Vmax
<i>A. U 3</i>	Voltage L3/L31	V/kV	0 to Vmax
<i>A. C1</i>	Current L1	A	0 to I <sub>max</sub>
<i>A. C2</i>	Current L2	A	0 to I <sub>max</sub>
<i>A. C3</i>	Current L3	A	0 to I <sub>max</sub>
<i>A. P</i>	Total kW	kW/MW	-P <sub>max</sub> to P <sub>max</sub>
<i>A. q</i>	Total kvar	kvar/Mvar	-P <sub>max</sub> to P <sub>max</sub>
<i>A. S</i>	Total kVA	kVA/MVA	0 to P <sub>max</sub>
<i>A. PF</i>	Total PF		-0.000 to 0.000
<i>A. PF.LG</i>	Total PF lag		0 to 1.000
<i>A. PF.Ld</i>	Total PF lead		0 to 1.000
<i>A. neU.C</i>	Neutral current	A	0 to I <sub>max</sub>
<i>A. Fr</i>	Frequency ①	Hz	0 to 100.00
<b>Present Demands</b>			
<i>Accd.P</i>	Accumulated kW demand	kW/MW	0 to P <sub>max</sub>
<i>Accd.S</i>	Accumulated kVA demand	kVA/MVA	0 to P <sub>max</sub>

**I<sub>max</sub>** (20% over-range) = 1.2 × CT primary current [A]

Direct wiring (PT Ratio = 1):

**V<sub>max</sub>** (690 V input option) = 828.0 V

**V<sub>max</sub>** (120 V input option) = 144.0 V

**P<sub>max</sub>** = (I<sub>max</sub> × V<sub>max</sub> × 3) [kW × 0.001] @ wiring modes 4Ln3, 3Ln3

**Pmax** =  $(I_{max} \times V_{max} \times 2)$  [kW x 0.001] @ wiring modes 4LL3, 3OP2, 3dir2, 3OP3, 3LL3

**NOTE:** **Pmax** is rounded to nearest whole kW units.

If **Pmax** is more than 9999.000 kW, it is truncated to 9999.000 kW

Wiring via PTs (PT Ratio > 1):

**Vmax** (690 V input option) =  $144 \times \text{PT Ratio}$  [V]

**Vmax** (120 V input option) =  $144 \times \text{PT Ratio}$  [V]

**Pmax** =  $(I_{max} \times V_{max} \times 3)/1000$  [MW x 0.001] @ wiring modes 4Ln3, 3Ln3

**Pmax** =  $(I_{max} \times V_{max} \times 2)/1000$  [MW x 0.001] @ wiring modes 4LL3, 3OP2, 3dir2, 3OP3, 3LL3

**NOTE:** **Pmax** is rounded to nearest whole kW units.

① The actual frequency range is 45.00 - 65.00 Hz

## 4.5 Pulsing Output Setup Menu

SELEC → CHG → ENTER ↑ ↓ → Puls → ENTER

This menu allows you to program any of the eight relays provided by your *C192PF8* instrument to output energy pulses. Relays #7 and #8 are especially recommended for use as pulsing relays because of their high endurance. Available pulsing parameters are listed in Table 4-5.



**To select a pulse relay:**

- ✓ Use the up/down arrow keys to scroll to the desired relay. The pulsing parameter assigned to the relay is displayed in the middle window, and the amount of unit-hours per pulse is displayed in the lower window.

**To change the pulse relay setup:**

- ✓ Press **SELECT** to activate the middle window.
- ✓ Use the up/down arrow keys to scroll to the desired output parameter. Selecting **nonE** disables pulsing through this relay.
- ✓ Press **SELECT** to activate the lower window.
- ✓ Use the up/down arrow keys to set the amount of unit-hours per pulse. The available range is 1-9999.
- ✓ Press **ENTER** to store the new setup, or press **ESC** to quit the setup without changes.

**To quit the pulsing setup menu:**

- ✓ From the upper window, press **ESC** or **ENTER**.

**Table 4-5 Pulsing Output Parameters**

Code	Parameter	Unit
<i>nonE</i>	Output disabled	
<i>Ac.Ei</i>	Active energy import	kWh import (positive)
<i>Ac.EE</i>	Active energy export	kWh export (negative)
<i>rE.Ei</i>	Reactive energy import	kvarh import (inductive)
<i>rE.EE</i>	Reactive energy export	kvarh export (capacitive)
<i>rE.Et</i>	Reactive energy total	kvarh total (absolute)
<i>AP.Et</i>	Apparent energy total	kVAh total

**NOTES**

1. You will not be able to store your setup in the instrument if you assigned a parameter to a relay output with a zero number of unit-hours per pulse.
2. If a relay you allocated for pulsing has been manually operated or released, it reverts automatically to normal operation.
3. If a relay you allocated for pulsing has been engaged by an alarm/event setpoint, the setpoint is automatically disabled.

## 4.6 Alarm/Event Setpoints Setup Menu

SELECT → CHG → ENTER ↑ ↓ → SETP → ENTER

Your instrument provides 16 alarm/event setpoints that can monitor a wide variety of events; in turn, these events can be programmed to trigger specific actions. This menu is used to specify the events to be monitored by the setpoints, and actions to be triggered by those events.

To program a setpoint, you might need to define up to six setup parameters which include: the setpoint trigger parameter, operate and release limits, optional operate and release delays, and the setpoint action. Table 4-6 explains the setpoint setup parameters. For the entire list of available triggers and setpoint actions, refer to Tables 4-7 and 4-8.

**Example:**

SP 1  
triG  
RHi.C1

Trigger parameter Setpoint 1 is set to monitor the real-time high current on phase 1 (the **trigger** parameter).



## NOTES

1. When you enter the setpoints setup menu at the protected level, monitoring of setpoints is temporarily suspended until you return to the main setup menu.
2. Each time you select a new trigger parameter, the operate and release limits are set by default to zero.
3. You will not be able to store your setpoint setup to the instrument if a setpoint action is directed to a relay allocated for pulsing.
4. The setpoint action directed to a relay output can be overridden using commands sent via communications. A relay can be manually operated or released. When the relay reverts to normal operation, it is automatically returned under setpoint control.

**Table 4-6 Setpoint Setup Options (middle window)**

Code	Option	Description
<i>trig</i>	Trigger parameter	The measurement parameter or signal to be monitored by the setpoint.
<i>On</i>	Operate limit	The threshold at which the setpoint becomes operative.
<i>OFF</i>	Release limit	The threshold at which the setpoint is released (becomes inoperative).
<i>On d</i>	Operate delay	The time delay (up to 999.9 sec. with 0.1 sec. resolution) before operation when the operate condition is fulfilled.
<i>OFF d</i>	Release delay	The time delay (up to 999.9 sec. with 0.1 sec. resolution) before release when the release condition is fulfilled.
<i>Act</i>	Setpoint action	The action performed when the setpoint is operative.

**Table 4-7 Setpoint Triggers (lower window, when middle window is *triG*)**

Code	Parameter	Unit	Range
<i>nonE</i>	Setpoint disabled		
<b>Status Input</b>			
<i>St.On</i>	Status input ON		
<i>St.OFF</i>	Status input OFF		
<b>No-Volt Trigger</b>			
<i>no-U</i>	No-Volt ④		
<b>Phase Reversal</b>			
<i>POS.ro.</i>	Positive phase rotation reversal ①		
<i>NEG.ro.</i>	Negative phase rotation reversal ①		
<b>Real-time Values on any Phase</b>			
<i>r. Hi. U</i>	High voltage ③	V	0 to Vmax
<i>r. Hi. LU</i>	High L-L voltage	V	0 to Vmax
<i>r. Lo. U</i>	Low voltage ③	V	0 to Vmax
<i>r. Lo. LU</i>	Low L-L voltage	V	0 to Vmax
<i>r. Hi. C</i>	High current	A	0 to Imax
<i>r. Lo. C</i>	Low current	A	0 to Imax
<i>r. thd.U</i>	High voltage THD	%	0 to 999.9
<i>r. thd.C</i>	High current THD	%	0 to 999.9
<i>r. HFc.C</i>	High K-factor	%	1.0 to 999.9
<i>r. tdd.C</i>	High current TDD	%	0 to 100.0
<b>Real-time Auxiliary Measurement:</b>			
<i>r. Hi.Fr</i>	High frequency ②	Hz	0 to 100.00
<i>r. Lo.Fr</i>	Low frequency ②	Hz	0 to 100.00

Code	Parameter	Unit	Range
<b>Average Values per Phase</b>			
A. Hi.C1	High current L1	A	0 to I <sub>max</sub>
A. Hi.C2	High current L2	A	0 to I <sub>max</sub>
A. Hi.C3	High current L3	A	0 to I <sub>max</sub>
A. Lo.C1	Low current L1	A	0 to I <sub>max</sub>
A. Lo.C2	Low current L2	A	0 to I <sub>max</sub>
A. Lo.C3	Low current L3	A	0 to I <sub>max</sub>
<b>Average Values on any Phase</b>			
A. Hi. U	High voltage ③	V	0 to V <sub>max</sub>
A. Hi. LU	High L-L voltage	V	0 to V <sub>max</sub>
A. Lo. U	Low voltage ③	V	0 to V <sub>max</sub>
A. Lo. LU	Low L-L voltage	V	0 to V <sub>max</sub>
A. Hi. C	High current	A	0 to I <sub>max</sub>
A. Lo. C	Low current	A	0 to I <sub>max</sub>
<b>Average Total Values</b>			
A. Hi.P.i	High total kW import (positive)	kW	0 to P <sub>max</sub>
A. Hi.P.E	High total kW export (negative)	kW	0 to P <sub>max</sub>
A. Hi.q.i	High total kvar import (positive)	kvar	0 to P <sub>max</sub>
A. Hi.q.E	High total kvar export (negative)	kvar	0 to P <sub>max</sub>
A. Hi. S	High total kVA	kVA	0 to P <sub>max</sub>
A. PF.LG	Low total PF Lag		0 to 1.000
A. PF.Ld	Low total PF Lead		0 to 1.000
<b>Average Auxiliary Measurements</b>			
Ar ne.U.C	High neutral current	A	0 to I <sub>max</sub>
Ar Hi.Fr	High frequency ②	Hz	0 to 100.00
Ar Lo.Fr	Low frequency ②	Hz	0 to 100.00
<b>Present Demands</b>			
Hi d.U1	High volt demand L1 ③	V	0 to V <sub>max</sub>
Hi d.U2	High volt demand L2 ③	V	0 to V <sub>max</sub>
Hi d.U3	High volt demand L3 ③	V	0 to V <sub>max</sub>
Hi d.C1	High ampere demand L1	A	0 to I <sub>max</sub>
Hi d.C2	High ampere demand L2	A	0 to I <sub>max</sub>
Hi d.C3	High ampere demand L3	A	0 to I <sub>max</sub>
Hi d.P	High block interval kW demand	kW	0 to P <sub>max</sub>
Hi d.S	High block interval kVA demand	kVA	0 to P <sub>max</sub>
Hi Sd.P	High sliding window kW demand	kW	0 to P <sub>max</sub>
Hi Sd.S	High sliding window kVA demand	kVA	0 to P <sub>max</sub>
Hi Ad.P	High accumulated kW demand	kW	0 to P <sub>max</sub>
Hi Ad.S	High accumulated kVA demand	kVA	0 to P <sub>max</sub>
Hi Pd.P	High predicted sliding window kW demand	kW	0 to P <sub>max</sub>
Hi Pd.S	High predicted sliding window kVA demand	kVA	0 to P <sub>max</sub>

For parameter limits, see notes to Table 4-4.

- ① The setpoint is operated when the actual phase sequence does not match the indicated normal phase rotation.
- ② The actual frequency range is 45.00 - 65.00 Hz.
- ③ When the 4LN3 or 3LN3 wiring mode is selected, the voltages will be line-to-neutral; for any other wiring mode, they will be line-to-line voltages.

- ④ The No-Volt trigger is intended for the use as a fast setpoint override condition for PFC operations in order to protect the capacitor banks against voltage interruptions. When used with the Hard Switch-Off action, it can de-energize the output relays in approximately 25 ms. This avoids bringing the still charged capacitors back after the voltage is restored. When used with other setpoint actions, this trigger can provide the response time to alarm conditions at 25-75 ms.

**Table 4-8 Setpoint Actions (lower window, when middle window is Act)**

<b>Code</b>	<b>Action</b>
<i>NonE</i>	No action ①
<i>ALAr</i>	Assert local alarm ②
<i>Hrd.OF</i>	Hard (immediate) switch-off of the PFC relays ③
<i>SFt.OF</i>	Soft (in turn) switch-off of the PFC relays ③
<i>rEL.1</i>	Operate relay #1 ④
<i>rEL.2</i>	Operate relay #2
<i>rEL.3</i>	Operate relay #3
<i>rEL.4</i>	Operate relay #4
<i>rEL.5</i>	Operate relay #5
<i>rEL.6</i>	Operate relay #6
<i>rEL.7</i>	Operate relay #7
<i>rEL.8</i>	Operate relay #8
<i>In.Cn.1</i>	Increment counter #1
<i>In.Cn.2</i>	Increment counter #2
<i>In.Cn.3</i>	Increment counter #3
<i>In.Cn.3</i>	Increment counter #3
<i>In.Cn.4</i>	Increment counter #4
<i>ti.Cn.1</i>	Count operating time using counter #1 ⑤
<i>ti.Cn.1</i>	Count operating time using counter #2
<i>ti.Cn.1</i>	Count operating time using counter #3
<i>ti.Cn.1</i>	Count operating time using counter #4

- ① When a setpoint is operated, its status is always stored to the alarm status register even if no action is assigned to the setpoint. The alarm status register can be polled and cleared through communications.
- ② This action causes the alarm LED on the front panel to light, giving the user a local alarm indication. The alarm LED operates in latched mode, i.e., even if an alarm condition disappears, the alarm LED continues to operate until the user acknowledges the alarm from the front panel (see Section 5.1). An alarm LED can be operated from any number of setpoints using an OR scheme.
- ③ These actions are intended for the use with the PFC alarm protection setpoints in order to protect the capacitor banks against harmful conditions that can cause damage.

When an alarm override condition is detected, the Hard Switch-Off action immediately switches out all the capacitor banks including those defined as permanently switched in. When used with the No-Volt trigger condition (see Note ④ to Table 4-7), this action provides the fastest possible response to voltage interruptions.

The Soft Switch-Off action switches off the capacitor banks progressively in pre-set disconnection intervals, as long as the alarm condition is present. This allows escaping the over-voltage or high harmonics conditions with minimum required cycling of the capacitor banks. The capacitor banks that are defined as permanently switched in will not be affected. After the alarm condition passes, the PFC will return to automatic operation after the safety delay which is 50 times the power factor setpoint operate delay (see Note ⑤ to Table 4-11).

- ④ Alarm relays operate in unlatched mode. This means that a relay is operated while an alarm condition is present and is automatically released when an alarm condition disappears. Each relay can be operated from any number of setpoints using an OR scheme, i.e., a relay will be operative while either of the alarm conditions is still present.
- ⑤ This action converts a common-use event counter to the dedicated time counter that measures time at 0.1-hour resolution while the setpoint is operative. Each time counter has a non-volatile shadow counter that counts time at 1-second resolution before the corresponding time counter is incremented. The time counters can be inspected via the Status Information Menu. They are labeled by an *hour* mark in the middle window.

## 4.7 Relay Operation Control Menu

**SELECT** → **CHG** → **ENTER** **↑** **↓** → **rELo** → **ENTER**

This menu allows you to set the relay operation mode: non-failsafe or failsafe. Failsafe relay operation is the opposite of normal operation where relay contacts are closed when a relay is operated (activated), and are open when a relay is released (de-activated). In failsafe mode, an alarm is activated by a non-energized relay which will open in all cases when an alarm condition is present or an alarm setpoint is not operational either due to a loss of control power or due to corruption of the setpoint setup configuration. A failsafe relay is closed only if it is under setpoint control and no alarm conditions exist, or if it is manually operated from the front panel or via communications.

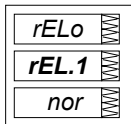

### **To select a relay:**

- ✓ Press **SELECT** to activate the middle window, and then use the up/down arrow keys to scroll to the desired relay.

### **To change the relay operation mode:**

- ✓ Press **SELECT** to activate the lower window.
- ✓ Use the up/down arrow keys to set the desired option. Select **nor** for normal (non-failsafe) relay operation, or select **FSAFE** for failsafe relay operation.
- ✓ Press **ENTER** to store your new setting or press **ESC** to leave your previous setting unchanged.

### **To quit the setup menu:**

- ✓ From the middle window, press **ESC** or **ENTER** .

## NOTES

1. You will not be able to change the relay operation mode if a relay has been allocated for pulsing or is controlled by the PFC.
2. When a failsafe relay is allocated for pulsing or to the PFC, it automatically reverts to normal operation.

## 4.8 Display Setup Menu

SELECT → CHG → ENTER ↑ ↓ → diSP → ENTER

This menu allows you to view and change display properties. Table 4-9 lists available options with their code names and applicable ranges.

**Table 4-9 Display Options** (\* default setting)

Display	Code	Parameter	Options	Description
diSP <b>UPdt</b> 0.5	<i>UPdt</i>	Display update time	0.1 - 10.0 s (0.5)*	Defines interval between display updates
diSP <b>ScrL</b> 5	<i>ScrL</i>	Auto scroll	<i>nonE*</i> 2-15 s	Disables/enables auto scroll on common measurements display (main screen) and defines scroll interval
diSP <b>rEtn</b> diS	<i>rEtn</i>	Auto return to the main screen	<i>diS*, En</i>	Disables/enables auto return to the main screen after 30 seconds of uninterrupted use
diSP <b>Ph.P</b> diS	<i>Ph.P</i>	Phase powers display mode	<i>diS*, En</i>	Disables/enables display of phase powers in common measurements (main screen)
diSP <b>Fund</b> diS	<i>Fund</i>	Fundamental values display mode	<i>diS*, En</i>	Disables/enables display of fundamental values in common measurements (main screen)

**To select a display option:**

- ✓ Press **SELECT** to activate the middle window, and then use the up/down arrow keys to scroll to the desired option.

**To change the display option:**

- ✓ Press **SELECT** to activate the lower window.
- ✓ Use the up/down arrow keys to set the desired option.
- ✓ Press **ENTER** to store your new setting or press **ESC** to leave your previous setting unchanged.

**To quit the display setup menu:**

- ✓ From the middle window, press **ESC** or **ENTER** .

## 4.9 User Selectable Options Menu



This menu allows you to change options which relate to the instrument features and functionality. Table 4-10 lists all available options with their code names and applicable ranges.

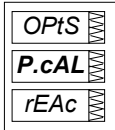

**To select an option:**

- ✓ Press **SELECT** to activate the middle window, and then use the up/down arrow keys to scroll to the desired option.

**To change the selected option:**

- ✓ Press **SELECT** to activate the lower window.
- ✓ Use the up/down arrow keys to set the desired value.
- ✓ Press **ENTER** to store your new setting or **ESC** to leave the previous setting unchanged.

**To quit the display setup menu:**

- ✓ From the middle window, press **ESC** or **ENTER** .

**Table 4-10 User Selectable Options** (\* default setting)

Code	Parameter	Options	Description
<i>P.cAL</i>	Power calculation mode ①	<i>rEAc</i> *	Using reactive power
		<i>nAct</i>	Using non-active power
<i>roLL</i>	Energy roll value ②	<i>10.E4</i>	10,000 kWh
		<i>10.E5</i>	100,000 kWh
		<i>10.E6</i>	1,000,000 kWh
		<i>10.E7</i>	10,000,000 kWh
		<i>10.E8</i> *	100,000,000 kWh
<i>Ph.En</i>	Phase energy measurements	<i>diS*</i> , <i>En</i>	Enables/disables measurements of energies per phase

① Power calculation mode (*P.cAL*):

Mode 1: Reactive power calculation (rEAc)

Active power P and reactive power Q are measured directly and apparent power

$$S = \sqrt{P^2 + Q^2}$$

Mode 2: Non-active power calculation (nAct)

Active power is measured directly, apparent power  $S = V \times I$  (where V, I - rms voltage and currents) and non-active power  $N = \sqrt{S^2 - P^2}$

Mode 1 is recommended for electrical networks with low harmonic distortion (voltage THD < 5%, current THD < 10%); Mode 2 is recommended for all other cases.

- ② Energy roll value example: If roll value = 10.E4, the energy counter contains 4 digits, i.e., energy is displayed up to 9.999 MWh (Mvarh, MVAh) with resolution 0.001 MWh.

Rollover Value	Maximum Energy kWh (kvarh, kVAh)	Maximum Display Reading MWh (Mvarh, MVAh)	Display Resolution MWh (Mvarh, MVAh)
10.E4	9,999	9.999	0.001
10.E5	99,999	99.999	0.001
10.E6	999,999	999.99	0.01
10.E7	9,999,999	9,999.9	0.1
10.E8	99,999,999	99,999	1

The roll value may be changed in accordance with the average load of the power line. For example, if average power is 400 kW and the counter must be reset every 3 months (2160 hours), then energy during this period equals 864000 kWh (6 digits) and the roll value = 10.E6.

## 4.10 Access Control Menu

**SELECT** → **CHG** → **ENTER** **↑** **↓** → **AccS** → **ENTER**

This menu can be only accessed via the *Setup Change Menu (CHG)*. It is used in order to:

- change the user password
- enable or disable password check

### **To view an option setting:**

- ✓ Press **SELECT** to activate the middle window.
- ✓ Use the up/down arrow keys to scroll to the desired option (*PASS* or *Ctrl*).

Password Setting

AccS
<b>PASS</b>
8780

Password Protection Control

AccS
<b>Ctrl</b>
OFF

### **To change the password:**

- ✓ Press **SELECT** to activate the lower window.
- ✓ Use the up/down arrow keys to modify the password. The password can be up to four digits long.
- ✓ Press **ENTER** to store your new password, or **ESC** to leave the password unchanged.

### **To enable/disable password checking:**

- ✓ Press **SELECT** to activate the middle window, and then use the up/down arrow keys to move to the **Ctrl** entry.
- ✓ Press **SELECT** to activate the lower window.
- ✓ Use the up/down arrow keys to change the password checking status: select **OFF** to disable password protection, or select **On** to enable password protection.
- ✓ Press **SELECT** to store your new option, or **ESC** to leave the option unchanged.

### **To quit the setup menu:**

- ✓ From the middle window, press **ESC** or **ENTER**.

**Store your password in a safe place. If you do not provide the correct password, you will need to contact your local distributor for the super-user password to override password protection.**

## 4.11 Reset/Synchronization Menu

**SELECT** → **CHG** → **ENTER** **↑** **↓** → **rSt** → **ENTER**

This menu allows you to reset to zero the accumulators and Min/Max registers in your instrument, and also to synchronize the power demand interval. The menu can be only accessed via the *Setup Change Menu (CHG)*. If the reset is disabled from the *Basic Setup Menu* (see Section 4.1), you will not be able to enter this menu.

The following designations are used to specify a data location to be affected:

<b>EnrG</b>	Resets total accumulated energies
<b>dnd</b>	Resets all total maximum demands
<b>P.dnd</b>	Resets total power maximum demands
<b>A.dnd</b>	Resets volt/ampere maximum demands
<b>Lo.Hi</b>	Resets Min/Max registers (does not affect maximum demands)
<b>Cnt</b>	Resets all event/time counters
<b>Cnt.1</b>	Resets event/time counter # 1
<b>Cnt.2</b>	Resets event/time counter # 2
<b>Cnt.3</b>	Resets event/time counter # 3
<b>Cnt.4</b>	Resets event/time counter # 4
<b>CYC</b>	Resets all PFC relay operation (banks switching cycle) counters
<b>CYC.1</b>	Resets PFC relay operation counter # 1
<b>CYC.2</b>	Resets PFC relay operation counter # 2
<b>CYC.3</b>	Resets PFC relay operation counter # 3
<b>CYC.4</b>	Resets PFC relay operation counter # 4
<b>CYC.5</b>	Resets PFC relay operation counter # 5
<b>CYC.6</b>	Resets PFC relay operation counter # 6
<b>CYC.7</b>	Resets PFC relay operation counter # 7
<b>CYC.8</b>	Resets PFC relay operation counter # 8
<b>d.Snc</b>	Provides synchronization of the power demand interval (see <b>NOTES</b> below)

### To reset the desired locations:

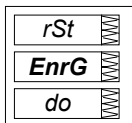

- ✓ Press **SELECT** to activate the middle window, and then use the up/down arrow keys to scroll to the desired data location entry.
- ✓ Press **SELECT** to activate the lower window.
- ✓ Press and hold **ENTER** for about 5 seconds until the **do** label is replaced with **done**, and then release the key. You will return to the middle window.

- ✓ Press **ESC** to quit the menu.

## NOTES:

1. If changing data in the instrument via the front panel is not secured by a password, fast reset of the Min/Max registers, maximum demands and energies can be done from the data display mode (see Section 6.1), and reset of counters from the Status Information Menu (see Section 7.1) without entering the reset menu.
2. If you select the *d.Snc* entry, take into consideration the following:
  - a) If the power demand period is specified in minutes (see Section 4.1, Basic Setup Options), this action provides synchronization of the instrument's internal timer. If the time expired from the beginning of the current demand interval is more than 30 seconds, the new demand interval starts immediately, otherwise synchronization is delayed until the next demand interval.
  - b) The synchronization is made at the moment delayed by exactly 5 seconds from the time you first pressed **ENTER** while you hold the key.

## 4.12 Manual Relay Control Menu

**SELECT** → **CHG** → **ENTER** **↑** **↓** → **rELc** → **ENTER**

This menu allows you to manually activate (force operated) or deactivate (force released) a relay if it is not allocated for pulsing and not controlled by the PFC. When a relay is controlled by the alarm setpoint, this command will override the setpoint alarm conditions until the relay is returned to normal operation.

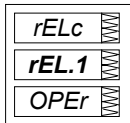

### To select a relay:

- ✓ Press **SELECT** to activate the middle window, and then use the up/down arrow keys to scroll to the desired relay.

### To change the relay status:

- ✓ Press **SELECT** to activate the lower window.
- ✓ Use the up/down arrow keys to set the desired option. Select **nor** for normal (setpoint-controlled) relay operation, select **OPEr** to activate a relay, or **rELS** to de-activate a relay.
- ✓ Press **ENTER** to store your new setting or press **ESC** to leave your previous setting unchanged.

### To quit the setup menu:

- ✓ From the middle window, press **ESC** or **ENTER**.

## NOTE

You will not be able to override the relay operation mode if a relay has been allocated for pulsing or is controlled by the PFC.

## 4.13 PFC Setup Menu

**SELECT** → **CHG** → **ENTER** → **PFC** → **ENTER**

This menu allows you to configure the PFC setup options and to set the PFC operation mode. Table 4-11 lists the PFC setup options, their code names and applicable ranges. For more information on the PFC options and operation, refer to Chapter 5, PFC Operation.

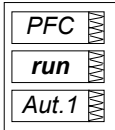

### To select and view a setup option:

- ✓ Press **SELECT** to activate the middle window
- ✓ Use the up/down arrow keys to scroll to the desired option. The current value for this option appears in the lower window.

### To change the value of the selected option:

- ✓ Press **SELECT** to make the lower window active.
- ✓ Press the up/down arrow keys to scroll to the desired value.
- ✓ Press **ENTER** to store the selected value, or press **ESC** to quit the setup menu.

**Table 4-11 PFC Setup Options (\* default setting)**

Code	Parameter	Options	Description
<i>run</i>	PFC operation mode	OFF*	The PFC is OFF/Shut down the PFC
		Aut.1	Self-adapting automatic mode. The capacitor banks are connected and disconnected progressively starting from the first available bank.
		Aut.2	Optimizing automatic mode. The capacitor banks are connected and disconnected in pre-optimized steps to reduce the number of switching operations.
		Hand	Safe manual operation mode. The banks are connected and disconnected progressively starting from the first available bank when user commands are entered from the front panel or through communications (see Section 4.14, PFC Manual Mode Menu).
<i>triG</i>	Power factor setpoint trigger	truE*	True power factor (based on true RMS calculations)
		H01	Fundamental harmonic's power factor (power factor displacement)
<i>SEtP</i>	Operational setpoints	PF1*	The target power factor range is defined by setpoint PF1.

Code	Parameter	Options	Description
<i>SEtP</i>		PF1-2 ②	Two target power factor ranges are defined by setpoints PF1 and PF2 (generally, to differentiate between day and night operations). The active setpoint range is selected through a digital (status) input.
<i>U.CAP</i>	Nominal voltage of the capacitor banks	0*, 1V to 999V, 0.01kV to 99.99kV ①	1V to 999V if PT RATIO = 1 0.01kV to 99.99 kV if PT RATIO > 1 0 = disable automatic adjustment of the capacitor bank powers to the measured line voltage (assuming that those have been adjusted manually)
<i>L.PF1</i>	Low target PF1	0.500 to -0.500 (0.800*)	Low target power factor for setpoint PF1
<i>H.PF1</i>	High target PF1	0.500 to -0.500 (0.980*)	High target power factor for setpoint PF1
<i>L.PF2</i> ③	Low target PF2	0.500 to -0.500 (0.800*)	Low target power factor for setpoint PF2
<i>H.PF2</i> ③	High target PF2	0.500 to -0.500 (0.980*)	High target power factor for setpoint PF2
<i>OP.d</i>	Setpoint operate delay, sec ⑤	1 to 600 s (3*)	The amount of time that the power factor must be continuously outside the setpoint range in order to run the automatic power factor correction
<i>On.d</i>	Switch-on time (connection interval), sec	3 to 600 s (30*)	The amount of idling time after a capacitor bank switches in, when further switching operations are prohibited
<i>OFF.d</i>	Switch-off time (disconnection interval), sec	3 to 600 s (3*)	The amount of idling time after a capacitor bank switches out, when further switching operations are prohibited
<i>rEc.d</i>	Re-connection (discharge) time, sec	5 to 600 s (30*)	The capacitor bank reclose delay to allow the capacitors to discharge after disconnecting
<i>CAP1</i>	Size of the capacitor bank #1, kvar	On, nonE*, 1 to 999 kvar	Power rating of the capacitor bank. nonE = not used, On = permanently switched in. ④
<i>CAP2</i>	Size of the capacitor bank #2, kvar	On, nonE*, 1 to 999 kvar	Power rating of the capacitor bank. nonE = not used, On = permanently switched in.
<i>CAP3</i>	Size of the capacitor bank #3, kvar	On, nonE*, 1 to 999 kvar	Power rating of the capacitor bank. nonE = not used, On = permanently switched in.

Code	Parameter	Options	Description
CAP4	Size of the capacitor bank #4, kvar	On, nonE*, 1 to 999 kvar	Power rating of the capacitor bank. nonE = not used, On = permanently switched in.
CAP5	Size of the capacitor bank #5, kvar	On, nonE*, 1 to 999 kvar	Power rating of the capacitor bank. nonE = not used, On = permanently switched in.
CAP6	Size of the capacitor bank #6, kvar	On, nonE*, 1 to 999 kvar	Power rating of the capacitor bank. nonE = not used, On = permanently switched in.
CAP7	Size of the capacitor bank #7, kvar	On, nonE*, 1 to 999 kvar	Power rating of the capacitor bank. nonE = not used, On = permanently switched in.
CAP8	Size of the capacitor bank #8, kvar	On, nonE*, 1 to 999 kvar	Power rating of the capacitor bank. nonE = not used, On = permanently switched in.

- ① When the PFC is programmed to operate with two power factor ranges, the active setpoint range is selected by the external contact status through the instrument's digital input: open = PF1, closed = PF2 setpoint range. To sense an external contact status, the digital input should be configured as a status input (see Section 4.3).
- ② Nominal voltage is shown in units of Volts as a whole number, or in kVolts with two decimal places.
- ③ These parameters appear only if setpoint PF2 is selected as an operational setpoint.
- ④ Setting this parameter to 'On' forces a capacitor bank to be permanently switched in when the PFC is put into an operation mode, and to be switched out when the PFC shuts down, following all switching and re-close time delays. The permanently switched banks continue under PFC protection but are not involved into either switching program.
- ⑤ This delay is also used in automatic operation modes as the reference restoration time when an alarm setpoint override condition takes place followed by the soft release of the capacitor banks (see Section 4.6). When the alarm condition is no longer present, the PFC will delay restoration of the automatic switching program for an amount of time equal to 50 times the power factor setpoint operate delay. This prevents excess cycling in over-voltage and high harmonics conditions.

#### NOTES:

1. The PFC setup parameters, except the operation mode, are protected from being changed while the PFC is running. Ensure that the PFC is OFF before configuring setup parameters. To disable protection after shutting the PFC down, exit the setup menu, and then re-enter the menu once more.
2. The PFC may not be put in either operation mode if no capacitor banks are specified in the PFC setup either as controlled or permanently switched banks.

3. The power rating values for the capacitor banks are not allowed to be in descending order. Each capacitor bank must have the same or higher power value than the previous bank. When entering the bank powers, the starting value is prompted at equal to the power of the previous bank and is not permitted to drop below this value.
4. The target power factor limits are always specified for the I and IV quadrants regardless of the location of the instrument on the source or load side. The PFC will automatically account for the direction of power flow providing full four-quadrant operation.
5. If both target power factor limits are specified for the same quadrant, the high power factor limit should never be less than the low limit. If the target limits are being set for two quadrants, the lagging (inductive) power factor should be specified as the low limit and the leading (capacitive) one as the high target limit. Whenever these relations are not fulfilled, the instrument will automatically adjust the high target power factor to the low target limit.



## 4.14 PFC Manual Mode Menu

**SELECT** → **CHG** → **ENTER** → **PFC.H** → **ENTER**

This menu allows you to manually operate (connect or disconnect) the PFC capacitor banks in progressive order by entering commands from the front panel. The menu can be only accessed via the *Setup Change Menu (CHG)* if the PFC is running in Manual Mode (see Section 4.13, PFC Setup).

When in the Manual Mode menu, the present measured power factor value is displayed in the upper window, the PFC operation status in the flashing middle window and measured reactive power in the lower window. Depending on the selected power factor setpoint trigger, the power factor and reactive power are based on the true RMS measurements or on the fundamental harmonic values. The PFC operation status reported in the middle window is explained in Table 4-12.

The up/down arrow keys function as command keys, as follows:

-  Switches in a capacitor bank
-  Switches out a capacitor bank

The capacitor banks are connected and disconnected progressively from the first controlled bank to the last, following all pre-set switching and re-connection delays. Whenever a number of the banks with the same size are available, the PFC will use at each step the bank that has the minimum number of switching cycles. A new command will not be accepted until the PFC has completed the previous command, i.e., until the reported PFC operation status is *Ready*, *Full* or *Idle*.

**To switch in a capacitor bank:**

- ✓ Ensure that the PFC is ready, and then press and release the up arrow key.

**To switch out a capacitor bank:**

- ✓ Ensure that the PFC is ready, and then press and release the down arrow key.

**To quit the menu:**

- ✓ Press  or .

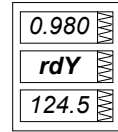

**Table 4-12 PFC Operation Status**

Code	Operation Status	Description
rdY	Ready	A switching program is complete
ALAr	Alarm	Operations are stopped by an alarm setpoint
buSY	Busy	Waiting until a switching delay is expired
FULL	Full	All capacitor banks are switched in
IdLE	Idle	All capacitor banks are switched out

**NOTE**

The Manual Mode commands do not affect the capacitor banks that are defined as permanently switched banks. These always switch in automatically when the PFC is put into operation, including in Manual Mode.

# Chapter 5 PFC Setup and Operation

This chapter describes how to setup the Power Factor Controller for your application and explains its important features. Brief instructions are included for certain setup and display operations. Complete setup instructions are found in Section 4.13, *PFC Setup*; complete display information is found in Chapter 6 (*Data Display*) and Chapter 7 (*Viewing Status Information*).

## 5.1 Capacitor Bank Control Options

The C192PF8 offers you three options to control capacitor banks in order to meet the conditions of your electrical equipment and avoid unnecessary switching. All options may be used at the same time when applied to different banks.

### Automatic Control

This option puts the banks under full PFC control and allows them to be used in either a manual or automatic PFC switching program.

To put the capacitor bank under PFC control, specify the bank size in kvar to allow for manual or automatic bank switching (see Section 4.13, *PFC Setup*).

### Manual Control

This option allows some of the banks to be manually switched in using direct control over the output relays. You can use this option for checking or repairing capacitor banks.

This option does not use the PFC to control the capacitor banks. Switching is done outside the PFC by directly forcing the output relays from the front panel (see Section 4.12, *Manual Relay Control Menu*) or via communications. The switched in banks remain connected until they are disconnected manually.

The size of the capacitor banks intended for direct manual control should be set to none (see Section 4.13, *PFC Setup*), thus moving them out of the PFC control.

Since the PFC does not manage the capacitor banks, and forcing the output relays also overrides the common alarm setpoint conditions, neither PFC setpoint protection nor common alarm setpoints can be used to protect the capacitor banks against harmful alarm conditions. This should be done separately, outside the C192PF8.

## Permanently Switched (Non-Programmable) Banks

This option allows some of the banks to be automatically switched in whenever the PFC is put into operation and to remain permanently connected any time the PFC is operating. This option is intended to avoid excess cycling of the capacitor banks that draw near their cycling limit, or to put constant capacitive load onto the network to avoid non-necessary switching.

To specify the bank as a permanently switched bank, set the bank size parameter to On (see Section 4.13, PFC Setup).

The permanently switched banks are switched in automatically when the PFC is put into either manual or automatic operation mode and before a switching program begins, and are switched out when the PFC shuts down, following all switching and re-connection time delays. These banks remain under PFC protection but are not involved into either switching program (assumed to be non-programmable banks).

## 5.2 PFC Operation

### 5.2.1 Modes of Operation

The PFC can operate in three control modes: self-adapting automatic mode, optimizing automatic mode, and manual mode. Both automatic modes provide automatic power factor correction whereby the PFC automatically accounts for deficient or excessive reactive power and makes necessary adjustments.

#### Self-adapting Automatic Mode (Auto 1)

Self-adapting mode is a simple automatic operation mode suitable to most applications. The PFC switches in additional banks while the measured power factor lags against the target power factor (excessive inductive load is detected), and switches out redundant banks when the measured power factor leads against the target power factor limits (excessive capacitive load is detected).

The capacitor banks are switched in and switched out progressively, always starting from the low-size bank available at this step, following the pre-set switching and re-connection delays.

The self-adapting program is complete when one of the following is true:

1. The measured power factor attains the pre-set power factor setpoint range.
2. The deviation from the target power factor is less than 0.7 of the smallest size bank.

## Automatic Optimization Mode (Auto 2)

This is a highly optimized operation mode that provides minimum switching operations. At each step, the PFC accounts for deficient inductive or capacitive reactive power to attain the target power factor and selects the exact combination of the banks among those presently available that requires the minimum number of switching operations.

Whenever no combination is found that allows achieving the target power factor range, the PFC will select a combination that provides minimum deviation from the target. When no leading (capacitive) target power factor is allowed, only combinations that provide lagging (inductive) power factor will be checked.

The banks are connected and disconnected starting from the low-size banks, following all pre-set switching and re-connection delays. Alternation of switching operations is provided when needed to avoid excessive deviation from the target power factor.

The optimization program is complete when one of the following is true:

1. The measured power factor attains the pre-set power factor setpoint range.
2. The deviation from the target power factor is less than 0.7 of the lowest-size bank.
3. The optimal combination may not be achieved. The controlled power factor is brought to the value that is as close as possible to the target power factor.

## Manual Mode

This mode can be used for manual adjustment of the power factor and for testing purposes. In manual operation mode, power factor correction is triggered by user commands entered from the front panel (see Section 4.14, PFC Manual Mode Menu) or through communications. Each command switches in or switches out a single capacitor bank. When there are no banks that can be operated or an alarm condition is present, the user command is discarded.

The banks are switched in and switched out progressively, always starting from the lowest-size bank available, following the pre-set switching and re-connection delays.

Manual Mode is a safe, fully protected operation mode provided that the setpoint protection overrides especially dedicated to the PFC are also operational here. Whenever the capacitor banks are protected through the alarm setpoints and an alarm override condition is present, the manual command will be overridden resulting in immediate or soft switch-off of the capacitor banks.

## Changing the Operation Mode

From the PFC setup menu (see Section 4.13, PFC Setup), set the operation mode parameter to the desired mode. This entry is always enabled unless the PFC is in Shut Down mode.

Changing from one operation mode to another mode can be done while the PFC is running, with no need to shut it down. The new program will start immediately from the present point achieved. No extra cycling will be made if the previous automatic program was completed. Changing to Manual Mode will stop all switching operations.

The PFC setup options (as well as certain basic configuration options) may not be changed while the PFC is running.

## Shutting the PFC Down

From the PFC setup menu, set the PFC operation mode to OFF. This will put the PFC into Shut Down mode.

Shut Down mode provides step-by-step disconnection of all the capacitor banks that are under the PFC control. The banks switch out progressively, following disconnection intervals (switch-off delays). After all the banks are switched out, the PFC is put into OFF state.

## 5.2.2 Power Factor Setpoints

When automatic operation is enabled, power factor correction is triggered automatically by the power factor setpoint whenever the measured power factor is outside the user-defined power factor setpoint range.

### Power Factor Setpoint Trigger

In order to operate reliably under various harmonic conditions, the PFC allows you to choose one of the following two calculation methods for the power factor trigger:

1. True power factor based on the true RMS calculations. It accounts for harmonics through the 15th, and is recommended for electrical networks where voltage THD is no more than 5%. For higher levels of harmonics, the power factor readings will vary too frequently, which may result in excess cycling of the capacitors unless you drastically increase the setpoint operate delay.
2. The power factor displacement based on the fundamental harmonic measurements. It does not account for presence of high harmonics and will give stable results in all conditions regardless of the present harmonics level.

## Operational Setpoints

Two target setpoint ranges can be defined, generally, for day and night operation, which are switched externally through the instrument digital input. They are designated as setpoints PF1 and PF2.

Unless you do intend to switch the power factor setpoint ranges, specify the operational setpoints as PF1. In this event, only the setpoint PF1 will be operational, and the PFC will not take into account the status of the digital input. The second setpoint will not even appear in the PFC setup menu.

If you want to use different target power factors and switch them depending on the time schedule or another external condition, specify the operational setpoints as PF1-2. In this event, both PF1 and PF2 setpoint ranges will be available for setup, and should be defined for proper operation. The PFC will always consider the status of the digital input in order to select an appropriate setpoint range: open = PF1, closed = PF2. Before running the PFC, configure the digital input as a status input (see Section 4.3).

## Power Factor Setpoint Ranges

The setpoint range limits are designated as L.PF1 (low target power factor) and Hi.PF1 (high target power factor) for the first setpoint, and as L.PF2 and H.PF2 for the second setpoint.

The allowable range for either power factor setpoint is 0.5 (inductive) to -0.5 (capacitive). The default setpoint range is 0.80 to 0.98.

The target power factor limits are always specified for the I (first) and IV (fourth) quadrants with positive (imported) active power, regardless of the location of the instrument on the source or load side. The PFC will automatically account for the direction of power flow providing full four-quadrant operation.

If both target power factor limits are specified for the same quadrant, the high power factor limit should never be less than the low limit. If the target limits are being set for two quadrants, the lagging (inductive) power factor should be specified as the low limit and the leading (capacitive) one as the high target limit. Whenever these relations are not fulfilled, the instrument will automatically adjust the high target power factor to the low target limit.

## Power Factor Setpoint Operate Delay

The power factor setpoint will not respond to the poor power factor if the time that the power factor is outside the setpoint range is less than the user-defined setpoint operate delay. This makes the trigger less sensitive to fast changes in load thus avoiding excess switching.

The operate delay timer is reloaded each time the measured power factor oversteps the setpoint range limits.

The allowable range for the operate delay is 1 to 600 sec. The default value is 3 sec.

### **Low Lacking Reactive Power**

To avoid excess cycling, the power factor setpoint will not trigger the PFC if the lacking reactive power is less than 0.7 of the lowest-size bank (usually with no load or in presence of very low load).

## **5.2.3 Switching Block Delays**

All bank-switching operations are performed following safety block delays in order to avoid excess transient voltages and currents, and to prevent possible damage to the contactors and capacitors.

### **Switch-on Delay (Connection Interval)**

This is the amount of time after the capacitor bank switches in during which the following switching operations are prohibited.

The PFC will not perform either connection or disconnection of the banks until the switch-on delay timer expires. This avoids multiple switching of the capacitor banks that would otherwise cause excess current pulses.

The switch-on delay can be adjusted from 3 to 600 sec. The default setting is 30 sec.

### **Switch-off Delay (Disconnection Interval)**

This is the amount of time after the capacitor bank switches out during which the following switching operations are prohibited.

The PFC will not perform either connection or disconnection of the banks until the switch-off delay timer expires. This avoids multiple switching of the capacitor banks that would otherwise cause excess transient voltages and currents in the circuits.

The switch-off delay can be adjusted from 3 to 600 sec. The default setting is 3 sec.

### **Re-connection (Re-close) Delay**

This is the amount of time after the capacitor bank switches out during which the re-connection of the bank is prohibited, in order to allow the capacitors to discharge. This avoids bringing the still-charged capacitors back after the voltage is restored that would otherwise cause permanent damage to the contactors and the capacitors because of extremely high over-voltage.

Normally, the capacitors discharge through fixed resistors that are connected to the capacitors directly or via auxiliary contacts of the contactors. Refer to the capacitor data sheet for the recommended discharge time for your capacitors.

The re-connection delay can be adjusted in the range of 3 to 600 sec. The default setting is 30 sec.

## 5.2.4 Arranging the Capacitor Banks

### Sizing of the Capacitor Banks

In order to provide reliable operation of the PFC, the sequence of the capacitor banks should admit different power combinations that must match the reactive load of your power network. The total power of all capacitor banks should be sufficient to provide refine power factor correction in worst cases of excessive inductive load.

It is recommended to use one of the following sequences of the capacitor banks, where all bank powers are multiples of the power of the first bank:

**c, c, c,....c;**  
**c, 2c, 2c,....2c;**  
**c, 2c, 4c,....4c;**  
**etc.**

where:

c = the power of the first capacitor bank, kvar;  
2c = twice the power of the first capacitor bank, kvar;  
4c = four times the power of the first capacitor bank, kvar;  
etc.

From the PFC setup menu (see Section 4.13, PFC Setup), specify the power ratings for the capacitor banks in kvar, progressively, starting from the first sized bank. The capacitor banks have the same numbers as the output relays to which they must be connected.

The power ratings are not allowed to follow in descending order. Each bank must have the same or greater size against the previous bank. When entering the bank power, the starting size is prompted at the power of the previous bank and will not be allowed to drop below this value.

The sized capacitor banks are not required to occupy adjacent output relays. They may alternate with permanently switched banks and not connected banks (see Section 5.1). In all cases, the first bank sized in kvar will be taken as the reference bank for PFC operations, and all sized banks will be treated in one sequence.

## Adjusting the Bank Rated Power to the Operating Voltage

The PFC calculates the network response to switching operations using the bank rated powers, normally given for the nominal (rated) voltage. Since the power of the capacitor banks extremely depends on the operating voltage, the PFC needs to adjust bank rated powers to the true operating voltage in the circuits.

The C192PF8 allows you to choose between manual and automatic adjustment of the capacitor bank powers. If you choose to make this manually, specify the bank nominal voltage in the PFC setup as zero, and then enter the reactive powers for each bank being recalculated for the operating voltage of the banks, as follows:

$$Q = Q_r \frac{V^2}{V_n^2}$$

where:

- Q - reactive power of the bank, kvar
- Q<sub>r</sub> - rated reactive power of the bank, kvar
- V - operating voltage, V
- V<sub>n</sub> - nominal (rated) voltage of the bank, V

If you allow for automatic adjustment of the bank powers, specify in the PFC setup the nominal voltage of your capacitor banks and the individual rated power for each capacitor bank. PFC will automatically account for the measured operating voltage to adjust the capacitor bank powers.

### 5.2.5 Relay Operation (Switching Cycle) Counters

In all modes of operation, the PFC tries to equate cycling for the banks with the same size. Whenever a number of the banks with the equal power are available, the PFC will use the bank that has the minimum number of switching cycles.

In order to control cycling of the capacitor banks and the contactors used for capacitor switching, the PFC maintains the individual operation counter (switching cycle counter), for each output relay. The cycle counter contains the number of complete switching cycles of the bank. The PFC updates the counter when it switches in the corresponding bank.

The present status of the cycle counters can be inspected through the Status Information Menu (see Chapter 7) or via communications. Each counter can be cleared individually or all counters together by a single operation (see Section 4.11 and Chapter 7).

## 5.3 Capacitor Banks Protection

### 5.3.1 PFC Protective Actions

The purpose of the PFC protection mechanism is to protect the capacitor banks and contactors against harmful conditions that would lead to extremely high over-voltage, or would cause undesirable effects such as high transient voltages and currents and high harmonics. The effect of the PFC protection is immediate, automatic disconnection of the capacitor banks that in the event of danger to capacitors, or progressively, in less dangerous situations, until alarm conditions disappear (with minimal cycling whenever possible).

In the C192PF8, all protective functions are provided through the universal mechanism of programmable alarm setpoints (see Section 4.6, Alarm/Event Setpoints Menu).

- ☑ The PFC itself has no embedded protection functions that may automatically disconnect the capacitor banks in such situations. With no setpoint protection, the capacitor banks will remain unprotected against damaging conditions unless external protection is used.

Any number of the 16 programmable setpoints can be used for PFC protection. Section 5.3.2 provides instructions on programming certain recommended setpoints for typical alarm conditions. Note that the effect of the setpoints does not depend on their order in the setpoint list.

- ☑ Protection of the capacitors against short circuits should be carried out separately using either fuses or switches with over-current protection.

The following two setpoint actions are specially intended for use with the PFC alarm protection setpoints.

#### Hard Switch-Off

When an alarm override condition is detected, the Hard Switch-Off action immediately switches out all the capacitor banks including those defined as permanently switched in. When used with the No-Volt trigger condition (see Table 4-7), this action provides the fastest possible response to voltage interruptions.

#### Soft Switch-Off

The Soft Switch-Off action switches off the capacitor banks progressively in pre-set disconnection intervals, while the alarm condition is present. This allows circumventing over-voltage or high harmonics conditions with minimum cycling of the capacitor banks. The banks that are defined as permanently switched in are not affected. After the alarm condition, the PFC will return to automatic operation after the safety delay which is 50 times the power factor setpoint operate delay.

## 5.3.2 PFC Protection Setpoints

### Protection against Voltage Interruptions

The fast disconnection of the capacitor banks is required in the event of short-term voltage interruptions that would cause damage to the still-charged capacitors when the voltage is restored.

The No-Volt alarm override condition (see Table 4.6) along with the Hard Switch-Off action can de-energize the output relays in approximately 25 ms whenever voltage interruption is detected.

From the Event/Alarm Setpoints Menu, set the setpoint parameters as follows:

Trigger	=	<b>no-U</b>
Operate Limit	=	<b>none</b>
Release Limit	=	<b>none</b>
Operate Delay	=	<b>0</b>
Release Delay	=	<b>3.0 sec</b>
Action	=	<b>Hrd.OF</b>

The setpoint release delay defines the amount of time before the PFC returns to normal operation after the alarm. Set it to a non-zero value (3.0 sec in the above example).

### Over-voltage Protection

Over-voltage override condition prevents damage to capacitors at high voltage increases that would be caused by faulty connections of the capacitors or by voltage resonance at a higher frequency.

The high voltage override condition along with the Soft Switch-Off action is recommended for over-voltage protection. The setpoint can respond to high measured voltage over 120% of the operating voltage with response time of 0.3 to 300 sec. The setpoint is released without a delay when the voltage returns to a level of 105-110% of the operating voltage. To avoid non-necessary disconnecting of the banks, the setpoint is released immediately when the alarm condition disappears.

From the Event/Alarm Setpoints Menu, set the setpoint parameters as follows (example):

Trigger	=	<b>r.hi. U</b>
Operate Limit	=	<b>115-120% of the operating voltage</b>
Release Limit	=	<b>110% of the operating voltage</b>
Operate Delay	=	<b>10 sec</b>
Release Delay	=	<b>0</b>
Action	=	<b>Sft.OF</b>

- After the alarm, the PFC will not return to automatic operation for a period of time that is 50 times the power factor setpoint operate delay.

## Protection against High Harmonics

High THD protection prevents damage to capacitors at high levels of voltage harmonics, which can be caused by voltage resonance at a higher frequency.

The effect of the high THD setpoint protection is limited progressive disconnection of the capacitor banks until resonance conditions disappear, and then, after a long safety delay, returning the PFC into normal operation.

The setpoint can operate at high THD of 3 to 300% depending on the network conditions with a delay of 0.3 to 300 seconds. The setpoint is released when the voltage THD drops to a level of 10-20% of the setpoint operate limit. To avoid un-necessary disconnecting of the banks, the setpoint is released without a delay.

From the Event/Alarm Setpoints Menu, set the setpoint parameters as follows (example):

Trigger	=	<b>r.thd.U</b>
Operate Limit	=	<b>5-10%</b>
Release Limit	=	<b>4-5% of the Operate Limit</b>
Operate Delay	=	<b>20 sec</b>
Release Delay	=	<b>0</b>
Action	=	<b>Sft.OF</b>

- After the alarm, the PFC will not return to automatic operation for a period of time that is 50 times the power factor setpoint operate delay.

## Protection by External Triggers

A protection setpoint can also be used to disconnect the capacitor banks in response to an external contact status provided through the instrument status input. This may be useful in substations with generators or large synchronous motors that generate a large amount of reactive power. The contact should be closed if generators or motors are working and opened if they are not working. The control signal can be provided from normally open auxiliary contacts of the start-up contactors.

From the Event/Alarm Setpoints Menu, set the setpoint parameters as follows (example):

Trigger	=	<b>St. On</b>
Operate Limit	=	<b>none</b>
Release Limit	=	<b>none</b>
Operate Delay	=	<b>5 sec</b>
Release Delay	=	<b>1 sec</b>
Action	=	<b>Hrd.OF or Sft.OF</b>







# Chapter 6 Data Display

## 6.1 Navigating in the Display Mode

The front panel has a simple interface that allows you to display numerous measurement parameters in up to 43 display pages. For easier reading, the parameters are divided into three groups, each accessible by a designated key. These are:

- **Common measurements** - no selection key
- **Min/Max measurements** - selected by the **MAX/MIN** key
- **Total Harmonic measurements** - selected by the **THD/TDD** key
- **Energy measurements** - selected by the **ENERGY** key

The up/down arrow keys are used as follows in the *Display Mode*:

-  Scrolls through the pages downward (forward)
-  Scrolls through the pages upward (backward)
-   Returns to the first page within current measurement group
-   When pressed for 5 seconds, clears the alarm LED



The front panel display is updated approximately twice per second; you can adjust the display update rate via the *Display Setup Menu* (see Section 4.8).

Table 5-1 lists all displayed parameters and their LED indicators.

### Relay Status Bar

The relay status bar displays the present status of the relays. When a relay is activated (switched on) the corresponding LED is lit.

### **Alarm/Man Mode LED**

This LED has two functions. The blinking LED indicates that the PFC is operating in Manual Mode.

The constantly lit LED gives you an alarm indication. It is controlled by the alarm/event setpoints (see Section 4.6) and operates in latched mode. Even if alarm conditions are no longer present, the alarm LED will continue to warn. To clear the alarm LED, press the up and down arrow keys simultaneously for 5 seconds.

### **Auto Scroll**

If display Auto Scroll option is enabled (see Section 4.8), the common measurements display (main screen) will scroll automatically after 30 seconds of uninterrupted use.

- ✓ To stop auto scrolling at the current page, press either arrow key.

### **Auto Return to the Main Screen**

If display Auto Return option is enabled (see Section 4.8), the display will automatically return to the main screen from any other measurement screen after 30 seconds of uninterrupted use.

### **Fast Reset of Accumulated Data**

When changing data via the front panel is not secured by a password, you can reset the Min/Max registers, maximum demands and energies from the display mode without entering the reset menu.

### **NOTES**

1. The common measurements display does not have a designated indicator LED. If no indicator LED is lit up below the display, this means that the common measurement parameters are being displayed at this time. To return to the common measurements from another group, just press the same key that you used to display this group (the key pointed to by an illuminated LED) until the illuminated LED goes out.
2. When you move to another measurement group, the instrument stores your last location; when you return to the previous group, the instrument restores the last page. At power up, the instrument always returns to the common measurements group and shows you the last page that was displayed prior to loss of power.

### **Selecting a Display Page**

- ✓ Press the down/up arrow keys to scroll through display pages.

### **Selecting Common Measurements**

- ✓ Press the key pointed to by the illuminated round LED below the front panel display. If no LED is lit up, this means that the front panel displays the common measurements parameters.

### Selecting Min/Max Measurements

- ✓ Press the **MAX/MIN** key. Use the up/down arrow keys to scroll through Min/Max measurements.

### Selecting Total Harmonic Measurements

- ✓ Press the **THD/TDD** key until the THD or TDD LED is illuminated. Use the up/down arrow keys to scroll through the different harmonic parameters.

### Selecting Energy Measurements

- ✓ Press the **ENERGY** key. Use the up/down arrow keys to scroll through the different energy readings.

### Fast Reset of Accumulated Data

- ✓ Select a display page where the data you want to reset is displayed. To reset:
  - Min/Max log registers: select a Min/Max page from the Min/Max measurements display (where a MAX or MIN round LED is illuminated).
  - Ampere and volt maximum demands: select the ampere or volt maximum demand page from the Min/Max measurements display (where a MAX DMD LED is illuminated, and volts or amps LEDs at the right are lit).
  - Power maximum demands: select the power maximum demand page from the Min/Max measurements display (where a MAX DMD LED is illuminated, and kVA/MVA and kW/MW LEDs at the right are lit).
  - Total and phase energies: select the energy measurements display.
- ✓ While holding the **SELECT** key, press and hold **ENTER** for about 5 seconds. The displayed data is reset to zero.

## 6.2 Data Display Formats

Table 6-1 specifies all front panel local displays available in the *display mode*. The display windows are labeled in the table as follows: 1 = upper window, 2 = middle window, 3 = lower window.

**Table 6-1 Displayed Parameters**

Page	Win- dow	Indicator LED	Parameter ①	Digits	Unit ②
<b>Common Measurements</b>					
1	1	<b>PF</b>	Total power factor	4	
1	2	<b>kVA</b>	Total kVA	4	kVA/MVA
1	3	<b>kvar</b>	Total kvar	4	kvar/Mvar
2	1	<b>V1/V1-2</b>	Voltage L12	4	V/kV
2	2	<b>V2/V2-3</b>	Voltage L23	4	V/kV
2	3	<b>V3/V3-1</b>	L. Voltage L31	4	V/kV
3	1	<b>V1/V1-2</b>	Voltage L1 ⑦	4	V/kV
3	2	<b>V2/V2-3</b>	Voltage L2 ⑦	4	V/kV
3	3	<b>V3/V3-1</b>	P. Voltage L3 ⑦	4	V/kV
4	1	<b>A1</b>	Current L1	4	A
4	2	<b>A2</b>	Current L2	4	A
4	3	<b>A3</b>	Current L3	4	A
5	1	<b>A NEUT</b>	Neutral current	4	A
5	2	<b>Hz</b>	Frequency	4	Hz
5	3	<b>kW</b>	Total kW	4	kW/MW
6	1	<b>PF</b>	Power factor L1	4	
6	2		<b>Ph.L1</b> ④		Label
6	3	<b>kW</b>	kW L1	4	kW/MW
7	1	<b>kVA</b>	kVA L1	4	kVA/MVA
7	2		<b>Ph.L1</b> ④		Label
7	3	<b>kvar</b>	kvar L1	4	kvar/Mvar
8	1	<b>PF</b>	Power factor L2	4	
8	2		<b>Ph.L2</b> ④		Label
8	3	<b>kW</b>	kW L2	4	kW/MW
9	1	<b>kVA</b>	kVA L2	4	kVA/MVA
9	2		<b>Ph.L2</b> ④		Label
9	3	<b>kvar</b>	kvar L2	4	kvar/Mvar
10	1	<b>PF</b>	Power factor L3	4	
10	2		<b>Ph.L3</b> ④		Label
10	3	<b>kW</b>	kW L3	4	kW/MW
11	1	<b>kVA</b>	kVA L3	4	kVA/MVA
11	2		<b>Ph.L3</b> ④		Label
11	3	<b>kvar</b>	kvar L3	4	kvar/Mvar
12	1	<b>PF</b>	H01 total power factor	4	
12	2		<b>H01</b> (Fundamental harmonic)		Label
12	3	<b>kvar</b>	Total kvar	4	kvar/Mvar

Page	Win- dow	Indicator LED	Parameter ①	Digits	Unit ②
13	1		<b>H01</b> (Fundamental harmonic)		Label
13	2	<b>kVA</b>	H01 total kVA	4	kVA/MVA
13	3	<b>kW</b>	H01 total kW	4	kW/MW
14	1	<b>PF</b>	H01 power factor L1	4	
14	2		<b>H1.L1</b> ④		Label
14	3	<b>kW</b>	H01 kW L1	4	kW/MW
15	1	<b>PF</b>	④ H01 power factor L2	4	
15	2		<b>H1.L2</b>		Label
15	3	<b>kW</b>	H01 kW L2	4	kW/MW
16	1	<b>PF</b>	H01 power factor L3	4	
16	2		<b>H1.L3</b> ④		Label
16	3	<b>kW</b>	H01 kW L3	4	kW/MW
17	1		<b>U.Unb</b>		Label
17	3		Voltage unbalance	4	%
18	1		<b>C.Unb</b>		Label
18	3		Current unbalance	4	%
<b>Min/Max Measurements</b>					
<b>MIN</b>					
1	1	<b>V1/V1-2</b>	Min. real-time voltage L1/L12 ⑥	4	V/kV
1	2	<b>V2/V2-3</b>	Min. real-time voltage L2/L23 ⑥	4	V/kV
1	3	<b>V3/V3-1</b>	Min. real-time voltage L3/L31 ⑥	4	V/kV
2	1	<b>A1</b>	Min. real-time current L1	4	A
2	2	<b>A2</b>	Min. real-time current L2	4	A
2	3	<b>A3</b>	Min. real-time current L3	4	A
3	1	<b>PF</b>	Min. real-time total power factor	4	
3	2	<b>kVA</b>	Min. real-time total kVA	4	kVA/MVA
3	3	<b>kvar</b>	Min. real-time total kvar	4	kvar/Mvar
4	1	<b>A NEUT</b>	Min. real-time neutral current	4	A
4	2	<b>Hz</b>	Min. real-time frequency	4	Hz
4	3	<b>kW</b>	Min. real-time total kW	4	kW/MW
<b>MAX</b>					
5	1	<b>V1/V1-2</b>	Max. real-time voltage L1/L12 ⑥	4	V/kV
5	2	<b>V2/V2-3</b>	Max. real-time voltage L2/L23 ⑥	4	V/kV
5	3	<b>V3/V3-1</b>	Max. real-time voltage L3/L31 ⑥	4	V/kV
6	1	<b>A1</b>	Max. real-time current L1	4	A
6	2	<b>A2</b>	Max. real-time current L2	4	A
6	3	<b>A3</b>	Max. real-time current L3	4	A
7	1	<b>PF</b>	Max. real-time total power factor	4	
7	2	<b>kVA</b>	Max. real-time total kVA	4	kVA/MVA
7	3	<b>kvar</b>	Max. real-time total kvar	4	kvar/Mvar
8	1	<b>A NEUT</b>	Max. real-time neutral current	4	A
8	2	<b>Hz</b>	Max. real-time frequency	4	Hz
8	3	<b>kW</b>	Max. real-time total kW	4	kW/MW

Page	Win- dow	Indicator LED	Parameter ①	Digits	Unit ②
<b>MAX DMD</b>					
9	1	<b>V1</b>	Max. volt demand L1/L12 ⑥	4	V/kV
9	2	<b>V2</b>	Max. volt demand L2/L23 ⑥	4	V/kV
9	3	<b>V3</b>	Max. volt demand L3/L31 ⑥	4	V/kV
<b>Total Harmonic Measurements</b>					
<b>THD</b>					
1	1	<b>V1/V1-2</b>	Voltage THD L1/L12	4	%
1	2	<b>V2/V2-3</b>	Voltage THD L2/L23	4	%
1	3	<b>V3/V3-1</b>	Voltage THD L3	4	%
2	1	<b>A1</b>	Current THD L1	4	%
2	2	<b>A2</b>	Current THD L2	4	%
2	3	<b>A3</b>	Current THD L3	4	%
<b>TDD</b>					
3	1	<b>A1</b>	Current TDD L1	4	%
3	2	<b>A2</b>	Current TDD L2	4	%
3	3	<b>A3</b>	Current TDD L3	4	%
<b>Total Energies</b>					
1	1	<b>MWh</b>	<b>Ac.En.</b>		Label
1	2		<b>IP.</b>		Label
1	3		MWh import	5	MWh
2	1	<b>Mvarh</b>	<b>rE.En.</b>		Label
2	2		<b>IP.</b>		Label
2	3		Mvarh import	5	Mvarh
3	1	<b>MVAh</b>	<b>AP.En.</b>		Label
3	3		MVAh	5	MVAh
4	1	<b>MWh</b>	<b>Ac.En.</b>		Label
4	2		<b>EP.</b>		Label
4	3		MWh export	5	MWh
5	1	<b>Mvarh</b>	<b>rE.En.</b>		Label
5	2		<b>EP.</b>		Label
5	3		Mvarh export	5	Mvarh
<b>Phase Energies ⑤</b>					
6	1	<b>MWh</b>	<b>Ac.En.</b>		Label
6	2		<b>IP.L1</b>		Label
6	3		MWh import L1	5	MWh

Page	Win- dow	Indicator LED	Parameter ①	Digits	Unit ②
7	1	<b>Mvarh</b>	<b>rE.En.</b>		Label
7	2		<b>IP.L1</b>		Label
7	3		Mvarh import L1	5	Mvarh
8	1	<b>MVAh</b>	<b>AP.En.</b>		Label
8	2		<b>L1</b>		Label
8	3		MVAh L1	5	MVAh
9	1	<b>MWh</b>	<b>Ac.En.</b>		Label
9	2		<b>IP.L2</b>		Label
9	3		MWh import L2	5	MWh
10	1	<b>Mvarh</b>	<b>rE.En.</b>		Label
10	2		<b>IP.L2</b>		Label
10	3		Mvarh import L2	5	Mvarh
11	1	<b>MVAh</b>	<b>AP.En.</b>		Label
11	2		<b>L2</b>		Label
11	3		MVAh L2	5	MVAh
12	1	<b>MWh</b>	<b>Ac.En.</b>		Label
12	2		<b>IP.L3</b>		Label
12	3		MWh import L3	5	MWh
13	1	<b>Mvarh</b>	<b>rE.En.</b>		Label
13	2		<b>IP.L3</b>		Label
13	3		Mvarh import L3	5	Mvarh
14	1	<b>MVAh</b>	<b>AP.En.</b>		Label
14	2		<b>L3</b>		Label
14	3		MVAh L3	5	MVAh

- ① Display readings for all electrical quantities except Min/Max log and energies are sliding average values.
- ② When using direct wiring (PT Ratio = 1), voltages are displayed in 0.1 V units, currents in 0.01 A units, and powers in 0.001 kW/kvar/kVA units. For wiring via PTs (PT Ratio > 1), voltages are displayed in 1V units, currents in 0.01 A units, and powers in 0.001 MW/Mvar/MVA units. When the value width is over the window resolution, the right most digits are truncated
- ③ By default, the maximum range for energy readings is 99,999,999 MWh/Mvarh/MVAh. Beyond this value, the reading will roll over to zero. When the energy reading exceeds the window resolution, the right-most digits are truncated. To avoid truncation, you can change the energy roll value to lower limit via the *User Selectable Options* menu (see Section 4.9). Negative (exported) energy readings are displayed without a sign.
- ④ Per phase power and power factor readings are displayed only in 4LN3/4LL3 and 3LN3/3LL3 wiring modes (see Section 4.1) if the phase powers display is enabled in the *Display Setup* menu (see Section 4.8).
- ⑤ Phase energy readings are displayed only in 4LN3/4LL3 and 3LN3/3LL3 wiring modes if they are enabled in the *User Selectable Options* menu (see Section 4.9).
- ⑥ When the 4LN3 or 3LN3 wiring mode is selected, the voltages will be line-to-neutral; for any other wiring mode, they will be line-to-line voltages.
- ⑦ Displayed only in the 4LN3 or 3LN3 wiring mode.

## 6.3 Self-Test Diagnostics Display

The *C192PF8* periodically performs self-test diagnostics during operation. If the instrument fails the test, it discards the last measurement results, and an error code is displayed for one second on all LEDs. Error codes are listed in Table 6-2. Code '8' indicates normal operation.

If the instrument continuously resets itself, contact your local distributor.

**Table 6-2 Self-Test Diagnostic Codes**

<b>Code</b>	<b>Meaning</b>
1	ROM error
2	RAM error
3	Watch dog timer reset
4	Sampling failure
5	Out of control trap
7	Timing failure
8	Normal power up
9	External reset (warm restart)

### NOTE

The *C192PF8* provides a self-check alarm register accessible through communications that indicates possible problems with instrument hardware or setup configuration. Hardware problems are indicated by the appropriate bits which are set whenever the instrument fails self-test diagnostics or in the event of loss of power. Setup configuration problems are indicated by the dedicated bit which is set when either configuration register is corrupted. In this event, your instrument will use the default configuration. For more information on the self-check alarm register, refer to the communications reference guides shipped with your instrument.

# Chapter 7 Viewing Status Information

Through the *Status Information Menu (StA)*, it is possible to view the status of various instrument features.

## 7.1 The Status Information Menu

**SELECT** → **StA** → **ENTER**

### **To enter the Status Information Menu:**

- ✓ From the display mode, press **SELECT** to enter the *Primary Selection Menu*.
- ✓ Press **SELECT** to activate the **StA** window.
- ✓ Press **ENTER** .

### **To select a display page:**

- ✓ Press the up/down arrow keys to scroll through the display pages.

### **To quit the menu and return to the display mode:**

- ✓ Press **ESC** or **ENTER** .

### **Front Panel Display**

When you are in the *Status Information Menu*, the front panel display is updated approximately four times per second and shows you a wide variety of status information that you can review by scrolling through display pages.

The status parameters are designated by the abbreviated labels in the upper and/or middle window. The upper window flashes, indicating that you are in the *Status Information Menu* display.

### **Fast Reset of Counters**

When changing data via the front panel is not secured by a password, you can reset the counters from the *Status Information Menu* display without entering the reset menu:

- ✓ Select a display page where the counter you want to reset is displayed.
- ✓ While holding the **SELECT** key, press and hold **ENTER** for about 5 seconds. The displayed data is reset to zero.

## 7.2 Status Display Formats

Table 7-1 lists all the displays available from the *Status Information Menu*. The display windows are labeled in the table as follows: 1 = upper window, 2 = middle window, 3 = lower window.

**Table 7-1 Status Information Display**

Page	Window	Parameter	Digits	Unit
1	1	<b>PFC</b>		Label
1	2	PFC operation mode (see Table 7-2)	4	
1	3	PFC operation status (see Table 7-3)	4	
2	1	<b>PHAS</b>		Label
2	2	<b>rOt</b>		Label
2	3	Phase rotation sequence (POS/NEG/ERR)	4	
3	1	<b>rEL</b>		Label
3	2	Relay #1 - #4 status	4	
3	3	Relay #5 - #8 status	4	
4	1	<b>St.In</b>		Label
4	3	Status input	1	
5	1	<b>Cnt.1</b>		Label
5	3	Event/Time counter #1	5	
6	1	<b>Cnt.2</b>		Label
6	3	Event/Time counter #2	5	
7	1	<b>Cnt.3</b>		Label
7	3	Event/Time counter #3	5	
8	1	<b>Cnt.4</b>		Label
8	3	Event/Time counter #4	5	
9	1	<b>CYC.1</b>		Label
9	3	PFC relay operation (switching cycle) counter #1	5	
10	1	<b>CYC.2</b>		Label
10	3	PFC relay operation (switching cycle) counter #2	5	
11	1	<b>CYC.3</b>		Label
11	3	PFC relay operation (switching cycle) counter #3	5	
12	1	<b>CYC.4</b>		Label
12	3	PFC relay operation (switching cycle) counter #4	5	
13	1	<b>CYC.5</b>		Label
13	3	PFC relay operation (switching cycle) counter #5	5	
14	1	<b>CYC.6</b>		Label
14	3	PFC relay operation (switching cycle) counter #6	5	

Page	Window	Parameter	Digits	Unit
15	1	<b>CYC.7</b>		Label
15	3	PFC relay operation (switching cycle) counter #7	5	
16	1	<b>CYC.8</b>		Label
16	3	PFC relay operation (switching cycle) counter #8	5	

**Table 7-2 PFC Operation Modes**

Code	Operation Mode
<b>OFF</b>	The PFC is switched OFF
<b>Sh.dn</b>	The PFC is shutting down
<b>Aut.1</b>	Self-adapting automatic operation mode
<b>Aut.2</b>	Optimizing automatic operation mode
<b>HAnd</b>	Manual operation mode

**Table 7-3 PFC Operation Status**

Code	Operation Status	Description
<b>rEAy</b>	Ready	A switching program is complete
<b>ALAr</b>	Alarm	Operations are stopped by an alarm setpoint
<b>buSY</b>	Busy	Waiting until a switching delay is expired
<b>Lo.rEA</b>	Low reactive power (automatic mode)	Insufficient reactive power to trigger PFC
<b>Ind.L</b>	Excessive inductive load (automatic mode)	Non-compensated inductive load
<b>CAP.L</b>	Excessive capacitive load (automatic mode)	Non-compensated capacitive load
<b>FULL</b>	Full (manual mode)	All capacitor banks are switched in
<b>IdLE</b>	Idle (manual mode)	All capacitor banks are switched out
<b>OFF</b>	OFF	The PFC is switched off

# Appendix: Technical Specifications

## Input and Output Ratings

3 galvanically isolated voltage inputs	690 V: (standard)	DIRECT INPUT (690V + 15% line-to-line voltage and 400V +15% line-to-neutral) Burden: <0.5 VA INPUT USING PT Burden: <0.15 VA
	120 V: (optional)	INPUT USING PT (120V +20% line-to-line voltage) Burden: <0.1 VA
3 galvanically isolated current inputs	5 A: (standard)	Maximum 6A RMS Burden: <0.1 VA Overload withstand: 10A RMS continuous, 250A RMS for 1 second
	1 A: (optional)	Maximum 1.2 A RMS Burden: <0.02 VA Overload withstand: 2A RMS continuous, 50A RMS for 1 second
Voltage and current input terminals		UL recognized Screws: Brass, M4 Maximum wire section: 2.5 mm <sup>2</sup> (12 AWG)
Optically isolated communication port		EIA RS-485 or RS-232 standard (factory set) RS-232: point-to-point, up to 15 meters RS-485: multidrop, up to 32 loads, up to 1200 meters (4000 ft.) Maximum wire section: 1.5 mm <sup>2</sup> (14 AWG)
Relay outputs		5 relays rated at 5A, 250 V AC / 5A, 30 V DC / 0.5A, 110 V DC 2 contacts (SPST Form A) 1 relay rated at 5A, 250 V AC / 5A, 30 V DC / 0.5A, 110 V DC 3 contacts (SPDT Form C) 2 relays rated at 3A, 250 V AC / 3A, 30 V DC / 0.5A, 110 V DC 2 contacts (SPST Form A) Maximum wire section: 1.5 mm <sup>2</sup> (16 AWG)
Analog output (optional) 4-20 mA 0-20 mA		Accuracy 0.5%, Non-linearity 0.2% Load up to 510 Ohm 24V DC external power supply required
Status input		Dry contact for external synchronization or monitoring Maximum impedance on: 300 ohm

## Display

3 windows, high-brightness seven-segment digit LEDs  
Color relay status LED

## Power Supply

*Galvanically isolated power supply (factory set)*

120&230V AC / 120&220 V DC  
12 V DC  
24 V DC  
48 V DC

85-265V AC 50/60 Hz and 88-290V DC 10 W  
9.6 - 19 V DC  
19 - 37 V DC  
37 - 72 V DC

## Environmental Conditions

*Operating temperature* -20°C to +60°C (-4°F to +140°F)

*Storage temperature* -25°C to +80°C (-13°F to +176°F)

*Humidity* 0 to 95% non-condensing

## Construction

*Instrument body* Case enclosure: flame resistant ABS & Polycarbonate Blend

Dimensions: 144 x 144 x 86 mm ( 5.67 x 5.67 x 3.39 “)

Mounting: 136 x 136 mm square cut-out (DIN 43700)

*Instrument weight* 0.9 kg (2.04 lb.)

## Standards Compliance

UL File # E129258 Pending

CE:

EMC: 89/336/EEC as amended by 92/31/EEC and 93/68/EEC

LVD: 72/23/EEC as amended by 93/68/EEC and 93/465/EEC

Harmonized standards to which conformity is declared:

EN55011:1991; EN50082-1:1992; EN61010-1:1993; A2/1995

Installation Category II, Pollution Degree 2

EN50081-2:1994 EMC Generic Emission Standard - Industrial Environment

EN50082-2:1995 EMC Generic Immunity Standard - Industrial Environment

EN55022: 1994 Class A

EN61000-4-2: 1995 Electrostatic Discharge

EN61000-4-4: 1995 Electrical Fast Transient

EN61000-4-8: 1993 Power Frequency Magnetic Field

ENV50140: 1993 Radio Frequency Electromagnetic Field, Amplitude Modulated

ENV50204: 1995 (200Hz) Radio Frequency Electromagnetic Field, Pulse Modulated

ENV50141: 1993 Radio Frequency Common Mode, Amplitude Modulated

ANSI C37.90.1: 1989 Surge Withstand Capability

ANSI IEEE C62.41-1991 Surge Voltages in Low-Voltage AC Power Circuits

## Measurement Specifications

Parameter	Full scale		Accuracy, %			Range	Display resolution (%Rdg) ② @ range
			Rdg	FS	Conditions		
Voltage	120V×PT @ 120V or 400V×PT @ 690V	For Ln reading and for 3OP2/3OP3 wiring modes		0.25	10% to 120% FS	0 to 999,000 V	Direct wiring (PT=1): 0.1 V @ 0.1V to 999.9 V  Wiring via PTs (PT>1): 0.001 kV @ 0.001kV to 9.999 kV ≤0.1% @ 10.00 kV to 999.0 kV  Starting voltage 1.5% FS
	208V×PT @ 120V or 690V×PT @ 690V	For LL reading except 3OP2/3OP3 wiring modes					
Line current	CT PRIMARY CURRENT			0.25	2% to 120% FS	0 to 9999 A	0.01 A @ 0.01A to 99.99 A ≤0.1% @ 100.0 A to 9999 A Starting current 0.5% FS
Active power	0.36×PT×CT @ 120V input 1.2×PT×CT @ 690V input			0.5	PF  ≥ 0.5 ①	-2,000,000 to +2,000,000 kW	Direct wiring (PT=1): 0.001 kW @ 0.001kW to 9.999 kW Wiring via PTs (PT>1): 0.001 MW @ 0.001MW to 9.999 MW ≤0.1% @ 10.00 MW to 2000 MW
Reactive power	0.36×PT×CT @ 120V input 1.2×PT×CT @ 690V input			0.5	PF  ≤ 0.9 ①	-2,000,000 to +2,000,000 kvar	Direct wiring (PT=1): 0.001 kvar @ 0.001kvar to 9.999 kvar Wiring via PTs (PT>1): 0.001 Mvar @ 0.001Mvar to 9.999 Mvar ≤0.1% @ 10.00 Mvar to 2000 Mvar

Parameter	Full scale	Accuracy, %			Range	Display resolution (%Rdg) ② @ range
		Rdg	FS	Conditions		
Apparent power	0.36×PT×CT @ 120V input 1.2×PT×CT @ 690V input		0.5	PF  ≥ 0.5 ①	0 to 2,000,000 kVA	Direct wiring (PT=1): 0.001 kVA @ 0.001kVA to 9.999 kVA Wiring via PTs (PT>1): 0.001 MVA @ 0.001MVA to 9.999 MVA ≤0.1% @ 10.00 MVA to 2000 MVA
Power factor	1		1	PF  ≥ 0.5, I ≥ 10% FSI	-0.999 to +1.000	0.001
Frequency		0.02			45.00 to 65.00 Hz	0.01 Hz
Neutral (unbalanced) current	CT PRIMARY CURRENT		0.5	2% to 120% FS	0 to 9999 A	0.01 A @ 0.01A to 99.99 A ≤0.1% @ 100.0 A to 9999 A Starting current 0.5% FS
Ampere demand	<i>same as for current</i>					
KW demand (block & sliding)	<i>same as for kW</i>					
KVA demand (block & sliding)	<i>same as for kVA</i>					
Total Harmonic Distortion THD U (I), % U <sub>1</sub> (I <sub>1</sub> )	999.9	1.5	0.2	≥ 0.1% FS, U (I) ≥ 10% FSU (FSI)	0 to 999.9	0.1
Total Demand Distortion TDD (I), % Active energy Import & Export	100		1.5	≥ 1% FS, I ≥ 10% FSI <i>according to power accuracy ③</i>	0 to 100 0 to 99,999 MWh	0.1 1 kWh @ 1 to 99,999 kWh 10 kWh @ 100 to 999.99 MWh 100 kWh @ 1,000 to 9,999.9 MWh 1MWh @ 10,000 to 99,999 MWh

Parameter	Full scale	Accuracy, %			Range	Display resolution (%Rdg) ② @ range
		Rdg	FS	Conditions		
Reactive energy Import & Export		according to power accuracy ③			0 to 99,999 Mvarh	1 kvarh @ 1 to 99,999 kvarh 10 kvarh @ 100 to 999.99 Mvarh 100 kvarh @ 1,000 to 9,999.9 Mvarh 1Mvarh @ 10,000 to 99,999 Mvarh
Apparent energy		according to power accuracy ③			0 to 99,999 MVAh	1 kVAh @ 1 to 99,999 kVAh 10 kVAh @ 100 to 999.99 MVAh 100 kVAh @ 1,000 to 9,999.9 MVAh 1MVAh @ 10,000 to 99,999 MVAh

PT = external potential transformer ratio

FSU = voltage full scale

U<sub>1</sub> = voltage fundamental

CT, CT Primary Current = primary current rating of external current transformer

FSI = current full scale

I<sub>1</sub> = current fundamental

① @ 10% to 120% of voltage FS and 2% to 120% of current FS ② Higher resolution is achievable via communications

③ Where the current is > 10% FS, the energy accuracy is better than 1.5% Rdg.

#### Additional Notes

1. Accuracy is expressed as  $\pm$  (percentage of reading + percentage of full scale)  $\pm$  1 digit. This does not include inaccuracies introduced by the user's potential and current transformers.
2. Specifications assume: voltage and current wave forms with THD  $\leq$  5% for kvar, kVA and PF; reference operating temperature: 20 - 26°C.
3. Ordinary measurement error is considerably less than the specified accuracy which indicates maximum error.

# INDEX

## A

accuracy, 71  
active energy, 4, 70, 71  
active power, 4, 5, 36, 69, 70  
alarms, 14  
ampere demand, 21, 30, 61  
**analog output**, 2, 5, 8, 15, 24,  
25  
**analog outputs**, 22

## B

basic setup, 20, 40  
burden, 67

## C

communications, 71  
controller, 55  
CT, 2, 21, 22, 25, 34, 69, 70, 71  
CT PRIMARY CURRENT, 22, 69,  
70, 71  
current inputs, 8, 67  
current transformers, 71

## D

**demand**, 3, 4, 15, 21, 23, 25, 30,  
38, 39, 58, 61, 70  
demand period, 15, 21, 39  
display, 1, 2, 33, 34, 35, 39, 45,  
56, 57, 58, 59, 62, 64, 65  
display mode, 34, 39, 57, 59, 64

## E

energy, 1, 2, 3, 4, 14, 26, 27, 35,  
36, 58, 62, 70, 71  
**external synchronization**, 3,  
15, 21, 23, 67

## F

frequency, 1, 3, 4, 5, 21, 29, 30,  
60, 70

## I

inputs, 23, 67

## L

**Load bar graph**, 56

## M

measurement, 71  
menu, 18, 20, 22, 23, 24, 26, 27,  
28, 29, 33, 34, 35, 37, 38, 39,  
40, 43, 44, 62, 64  
Modbus, ii, 17, 21, 22  
mounting, 1, 7

## O

open delta, 10, 21, 40, 41  
options, 15  
overload withstand, 67

## P

panel cut-out, 7  
password, 2, 18, 37, 39, 57, 64  
PComTest, 20  
**power**, i, ii, 1, 2, 3, 4, 5, 8, 15,  
21, 22, 23, 24, 33, 35, 36, 38,  
39, 50, 51, 55, 57, 58, 59, 60,  
61, 62, 63, 67, 68, 69, 70, 71  
**power demand**, 3, 4, 15, 21, 23,  
38, 39  
**power factor**, 1, 50, 55, 70  
**power source**, i, ii, 8  
**power supply**, 68  
PT, 8, 21, 22, 25, 26, 62, 67, 69,  
70, 71  
PT RATIO, 22  
**pulsing**, 2, 14, 26, 27, 29, 33, 39

## R

reactive energy, 4, 71  
reactive power, 4, 5, 35, 36, 55, 69  
**relays**, 2, 14, 26, 32, 67  
reset, 21, 36, 38, 39, 57, 58, 63,  
64

## S

self tests, 63  
**setpoints**, 22, 27, 28, 29, 31, 32,  
57  
setup menus, 18, 20

setup mode, 18  
sliding demand, 4  
standards, 67, 68  
status, 1, 3, 15, 18, 23, 31, 37,  
55, 64, 65

### T

technical specifications, 67  
terminals, ii, 8, 67

### V

*voltage inputs*, 67

### W

**wiring configuration**, 5, 8, 10  
Wye, 10, 21, 40